



Swimming Pool and Spa Packet

BI-23

CBC 2022

Swimming Pool and Spa Plan Submittal Requirements and Plan Check Correction List.

Minimum 11 x 17" Plan Sheets Required for Pools and Spas

The following handouts / information sheets must be printed onto the plans:

Attachments Included:

1. Special Inspection List and Table 1704.4 (2 pages) ***Imprint on plans.***
2. BI-21 Pool and Spa Construction and Inspection Guide and State Energy Regulations for Swimming Pools ***Imprint on plans.***
3. BI-17 Pool Barrier Compliance (3 pages) ***Imprint on plans***
4. BI-27 Pollution Prevention For Construction (completed and signed) (4 pages) ***Imprint on plans.***



CITY OF SAN CLEMENTE
BUILDING DIVISION
 910 Calle Negocio, Suite #100 San
 Clemente, CA 92673
 (949) 361-6100

City
 Applicant

SWIMMING POOL & SPA
PLAN SUBMITTAL REQUIREMENTS &
PLAN CORRECTION LIST
BASED ON 2022 CALIFORNIA CODES

PLAN REVIEW # _____

Address _____

Owner _____

Designer _____

Scope of Work: Pool Spa Pool & Spa

1. Provide name and address on the plans for:
 - a. Owner
 - b. Plan preparer (with signature)
 - c. Engineer
2. On adjacent properties, show all climbable structures within 5 feet of property lines, **or** imprint on the site plan the following note: ***“There are no climbable permanent structures on adjacent properties within 5 feet of proposed or existing pool barriers”.***
3. Imprint the following note on the plans: ***“The Equipotential Bonding required by current adopted CA. Elec. Code Article 680, shall be installed to eliminate voltage gradients in the pool area as prescribed.”***
4. Imprint on the plans the following (completed and signed):

Prior to excavation all revision/changes to the proposed and existing pool barriers shown on approved plans shall be HOA approved, submitted for City plan review and approved, permit issued and field inspection signed off by City of San Clemente Building Inspector.

Owner Print Name _____ **Owner**
Signature _____ **Date** _____
Contractor Print Name _____ **Contractor**
Signature _____ **Date** _____

5. Provide a complete site plan showing the following:
 - a. Property lines clearly identified.
 - b. Proposed pool, spa shape, dimensions and location to show setbacks and clearance from existing and proposed structures. Show setback to Property line from waters edge.
 - c. Pool barrier fencing and gate location, show height & description/type of fencing.
 - d. Show existing structures on site and any proposed structures (house, garage, retaining

walls, patio cover, deck, etc...).

- e. Location of pool/spa equipment and noise containment plan.
- f. Topography of the site with indicating top and bottom of slopes (if any) on and adjacent (neighbors) properties.
- g. Indicate overhead utilities and electric service drops **or** specify underground utilities.
- h. Show outdoor showers if applicable with water and drainage.

6. Pools shall be setback from top and bottom of slopes as required by City of San Clemente grading ordinance (see FIGURE 1). The building official may approve alternate setbacks and clearances when a soils investigation by a qualified engineer demonstrates the intent of the code has been satisfied. The report shall be prepared by a licensed Geotechnical or Civil Engineer that addresses the location of pool/spa, soil conditions and slope stability.

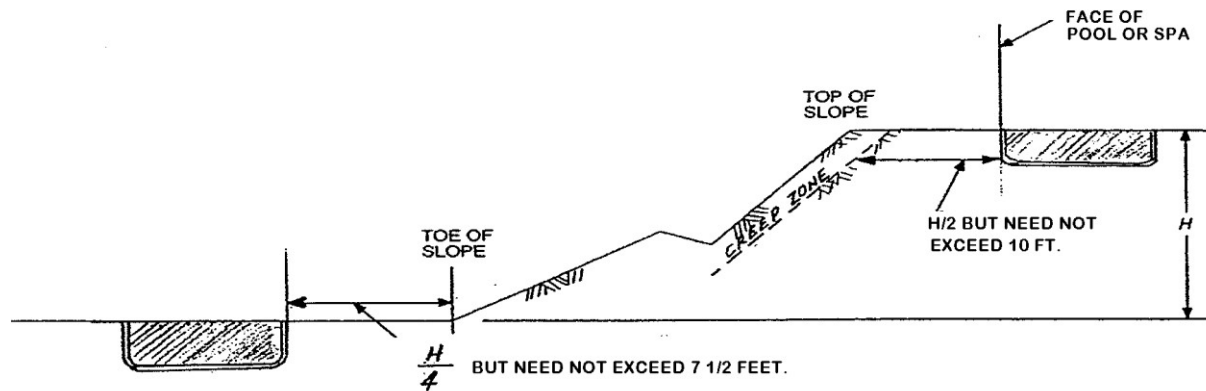

FIGURE 1 - SETBACK DIMENSIONS

7. That portion of pool or spa wall within a horizontal distance of 7 feet from top of slope shall be capable of supporting the water in the pool or spa without soil support. (CBC 1808A.7.3)
8. A licensed Civil, Structural, Geotechnical Engineer or Architect must approve the location of the pool by reviewing and stamping the site plan. The site plan shall be signed and stamped by the Engineer or Architect.
9. Each sheet of the pool plans shall be signed and stamped by a licensed Civil, Structural Engineer or Architect.
10. The Engineer or Architect shall circle all sections and details on generic pool plans which are applicable to the project and cross reference details on the pool plan to indicate applicable locations.
11. A minimum of two cross-sections of the pool (**other than standard structural details**) shall be shown. These two cross-sections shall show the following:
 - a. Distance from the pool to top or bottom of slopes
 - b. Distances from pool to the adjacent buildings or structures.
 - c. Show all dimensions on cross sections.
12. Structural calculations for pool and/or spa (and retaining walls) prepared by a licensed Civil or Structural Engineer are required. Calculations shall include all surcharges from slopes and/or adjacent structures.
13. Retaining walls proposed that modify existing slopes require separate permit and review and must

be submitted prior to or along with the pool / spa plans. Structural calculations prepared by a licensed Civil or Structural engineer shall be provided at the time of submittal.

14. Due to expansive soils typical in much of San Clemente, pool and spa shells (and retaining walls) shall be designed and constructed to conform with expansive details using lateral earth pressure of 100 psf/ft equivalent fluid pressure (or greater if required by soils report). Exception: Design engineer may utilize lower lateral pressures for design when soils letter/report is provided that recommends lower pressures.
16. Protection of adjoining property. The person making or causing an excavation to be made shall provide written notice to the owners of adjoining buildings advising them that the excavation is to be made and that the adjoining buildings should be protected. Said notification shall be delivered not less than 10 days prior to the scheduled starting date of the excavation.
17. Clearly identify and distinguish between existing hardscape and landscape and new/proposed hardscape and landscape improvements.
18. Show location of all fencing on the plans. Provide section and/or elevation for all required pool fencing. Comply with the following requirements:
 - a. Height: 5 feet minimum above exterior grade.
 - b. Climability: 45 inches minimum between outside horizontal members.
 - c. Openings: shall not allow passage of 4 inch diameter sphere between vertical members.
 - d. Bottom of fence to be within 2 inches of firm soil or pavement.
 - e. The area outside the fence must be free of items that can be climbed to allow access to the pool. This does not require the neighboring property to perform any act but rather requires the pool owner to provide an alternate design to provide a complete pool enclosure.
 - f. Gates open outward away from the pool area and are self closing and latching with the latch located at a minimum height of 54 inches if it can be reached from the outside.
19. Pools and spas are required to be protected by barriers that prevent access by children. The Pool Safety Act defines the required fencing and other safety measures required to prevent drowning. The pool safety act is amended by City Ordinance to provide a fence/barrier around the pool and have an additional safety measure added.
 - A. All Pools are required to have a barrier completely around the pool. This is typically a fence that meets the requirements of #18 above. In addition to the required fence one more safety measure is required to be installed.
 1. minimum height of 60 inches.
 2. gaps or voids do not allow passage of a sphere equal to or greater than 4 inches.
 3. outside surface free of protrusions, cavities or other physical characteristics that would serve as handhold or footholds that could enable a child below the age of five years to climb over, any horizontal elements providing foot holds must provide an open space of 45 inches between horizontal elements to prevent a ladder affect.
 4. a vertical clearance from the ground to the bottom of the fence of 2 inches,
 - B. Where a wall of a dwelling serves as part of the barrier: **Two** of the methods listed below must be used to protect the pool from unauthorized entry by children from the house:

1. Doors with direct access to pool shall be equipped with an alarm, which produces an audible warning when the door and its screen, if present, are opened. The alarm shall sound continuously for a minimum of thirty (30) seconds immediately after the door is opened and be capable of being heard throughout the house during normal household activities. The alarm shall automatically reset under all conditions. The alarm shall be equipped with a manual means, such as touchpad or switch to temporarily deactivate the alarm for a single opening. Such deactivation shall last not more than fifteen (15) seconds. The deactivation switch shall be located at least fifty-four (54) inches above the threshold of the door. **Provide product** specifications for any proposed door alarm system and show all locations on the plans. Or:
 2. a removable mesh fencing that meets ASTM F2286 standard in conjunction with a gate that is self-closing and self-latching and can accommodate a key lockable device. Or:
 3. An approved safety pool cover that meets ASTM F1346-91, Or:
 4. Doors with direct access to the pool be self-closing and self-latching with a release mechanism placed no lower than 54 inches above the floor. Or:
 5. an alarm when placed in a swimming pool will sound upon detection of accidental or unauthorized entrance into the water. The alarm shall meet ASTM standard F2208 that includes surface motion, pressure, sonar, laser, and infrared type alarms. Or:
 6. other means of protection that afford equal protection of any of the above features and that has been tested to meet ASTM standards.
- 20 Provide safety glazing in fences, doors and windows, where the glass is located within 5 feet from edge of pool/spa and less than 60 inches above grade.
21. All exterior receptacles must be GFCI protected. Locate all exterior receptacles on plans. Per NEC 680.22 (A) (1). At least one receptacle on a general purpose branch circuit shall be located a minimum 6 feet from and not more than 20 feet from the inside wall of the pool.
- 22 The mechanical code requires that pool and spa heater vents are located a minimum of 4 feet from openings into a building. Show openings on plans or Note “No openings within 4 feet.”
23. Indicate size and location of gas lines to pool/spa/BBQ/fireplace, etc. show size of each section. Gas piping shall not be installed under patio cover, deck or other structures, unless installed in vented sleeve. (Provide detail and location if using sleeve)
24. Specify gas piping materials to be used above and below ground. (metallic gas piping is prohibited underground by San Clemente ordinance)
25. Filters, heating systems, and pumps installed with pools, spas, hot tubs, waterfall or any other man-made body of water, shall be enclosed and soundproofed to meet the City Noise Ordinance. Provide details of sound enclosure wall and cross reference details on plans.
26. Show locations and width of all easements on the site plan. No improvements shall be located within the easement area. If there are no easements, provide a note on the plan signed by the designer, owner or contractor as follows: **“I have verified the subject property’s grant deed and title report and have found no easements in the area of the proposed construction. I acknowledge that I am responsible and accountable for not constructing in the easements”**.



SPECIAL INSPECTION LIST
POOL/SPA

Project No: _____

Permit No: _____

Project Address: _____

Description of Type of Inspection Required
Location, Remarks, etc.

	Strength	City Inspector	Date
POOL EXCAVATION: Geotechnical Engineer shall observe the site and excavation/soil conditions and provide written field memo that states the pool/spa location and soil conditions are satisfactory from a geological standpoint.			
Geotech Engineer shall certify pool bottom conforms to Structural Note 1 on STD POOL STRUCTURAL PLAN, otherwise contractor shall advise pool engineer of non-conformity to said note.	S.P. = 1,500 psf min. and no dissimilar soils conditions under pool area		
SHOTCRETE/GUNITE: Provide concrete test results for concrete foundation in contact with soluble sulfate soils. (CBC 1913.10)	Type V f'c = 4500 psi <u>Water</u> = 0.45 Cement		
SHOTCRETE/GUNITE PLACEMENT per CBC. Section 1704.4 and 1913.			
ACCOUSTICAL REPORT	Max 55 DBA 7:00 am-10:00 pm Max 50 DBA 10:00 pm – 7:00 am		

1. The special inspections listed are in addition to the called inspections required by the California Building Code.
2. Continuous inspection by a Special Inspector is required during the performance of this work unless otherwise specified. This Special Inspection is not a substitute for inspection by a City Inspector. Specially inspected work installed or covered without the approval of the City Inspector is subject to removal or exposure.
3. The Special Inspector must be approved by the City of San Clemente in advance in order to perform the types of Inspection specified.
4. It is the responsibility of the Contractor to schedule the time with the Special Inspector of Inspection Agency prior to performing any work that requires special inspection. All work shown above performed without required special inspection is subject to removal.
5. Special Inspection reports shall be submitted to the Building Division for approval prior to City Inspector approval of that work.



Pool and Spa Construction and Inspection Guide

BI-21

CBC 2022

BARRIERS

1. Barrier fence shall be in place prior to pre-plaster inspection. Existing fences used as a barrier must meet the barrier requirements prior to proceeding with the pool plastering.

LOCATION:

1. Pool and equipment shall be located per the approved plans.
2. Pool and Spa equipment shall be placed in a sound barrier enclosure (i.e. covered block wall).

POOL DESIGN:

1. Use approved plans for pool shell.
2. If pool is within house surcharge area, see the engineers' requirements.
3. Storm water shall not drain into the pool from other structures and the site. Decks shall drain to street via approved drainage system. Filter wash shall be retained on site.

ROUGH PLUMBING AND ELECTRICAL INSPECTION

1. Use K copper and plastic pipe. Copper-depth of lines to be 12 inches under concrete.
2. The pool heater shall be installed per its listing. There must be a length of plumbing (36 inch minimum) between the filter and the heater to allow for the possible future addition of solar heating equipment.
3. Electric wiring shall be in plastic conduit. Schedule 80 above ground and securely mounted.
4. Use tracer wire (Minimum #14 copper plastic covered) with polyethylene (PE) gas piping.
5. Pressure test gas line (10 p.s.i. for 15 minutes).
6. Pump circuits and outlets shall be GFCI protected. Provide a 120V GFCI receptacle between 6 ft. and 20 ft. from water's edge. Provide waterproof switches and receptacles.
7. A #8 copper bonding wire shall effectively bond all metal elements of the pool including handrails, pumps, and fences within 5 feet of the pool.

FINAL INSPECTION:

1. Secondary Pool barriers and safety devices shall be in place at final.
2. The pool pump and heater shall be operational at the final inspection.
3. If the pool or spa is heated, thermal cover is required per the CA Energy Code Section 110.4b 2.

City of San Clemente

Building Division

910 Calle Negocio, Suite 100, San Clemente, CA 92673

Phone (949) 361-6100

www.san-clemente.org



Pool Barrier Compliance

BI-17

California Building Code Section 3109 has included the California Swimming Pool Safety Act to regulate statewide measures to prevent drowning of children. The barriers will be inspected prior to the plastering inspection and all deficiencies corrected prior to approval to plaster and fill the pool. At the final inspection all measures must be in place..

I further acknowledge and understand that as soon as my swimming pool/spa is filled with water and after final inspection, I am responsible to maintain the required pool barriers at all times.

Project Address

Permit Number

Owner Name (print)

Date

Owner Signature

Contractor (Print)

Date

Contractor (Signature)

**POOL BARRIER COMPLIANCE FORM
SHALL BE SIGNED PRIOR TO PERMIT ISSUANCE**

City of San Clemente Building Division, 910 Calle Negocio, Suite 100, San Clemente, CA 92673
Phone (949) 361-6100 - www.san-clemente.org

Rev 05/15/2024

Pool Barrier and Safety Devices

- A. Pools must have two safety measures to prevent unauthorized entry or warn of entry into the pool. The first measure is always the pool barrier that surrounds the pool. The second measure will be one of the following methods:**
- 1. An electric automatic safety pool cover conforming to ASTM Standard F-I 346-91 with control for the pool cover mounted at least 54 inches above grade, or,**
 - 2. An alarm placed in the pool or spa will sound upon detection of accidental or unauthorized entrance into the water. The alarm shall meet and be independently certified to the ASTM standard F2208 including water motion, pressure, sonar, laser, and infrared systems or,**
 - 3. Other means of protection may be acceptable as long as the degree of protection provided is not less than that required by any of the devices described above.**
- B. Where a wall of a dwelling serves as part of the barrier two additional safety measures shall be used. Any two of the six measures listed below may be used to separate and protect the occupants of the home. The intent is to always provide two methods of protection from any possible point of entry.**
- 1 Removable mesh fencing that meets ASTM standards in conjunction with a gate that is self-closing and self-latching and can accommodate a key lockable device or,**
 - 2 Self-closing exterior doors with self-latching devices installed at fifty-four (54") above inside floor level or,**
 - 3 All doors opening into the pool area supervised by an alarm that will sound an alarm noise or a verbal warning, or**
 - 4. An electric automatic safety pool cover conforming to ASTM Standard F-I 346-91 with control for the pool cover mounted at least 54 inches above grade, or,**
 - 5. An alarm placed in the pool or spa will sound upon detection of accidental or unauthorized entrance into the water. The alarm shall meet and be independently certified to the ASTM standard F2208 including water motion, pressure, sonar, laser, and infrared systems or,**
 - 6. Other means of protection may be acceptable as long as the degree of protection provided is not less than that required by any of the devices described above.**
- C. Where an above ground pool structure is used as a barrier or where the barrier is mounted on top of the pool structure, and the means of access is a ladder or steps, then**
- (1) the ladder or steps shall be capable of being raised, locked, or removed to prevent access or,**
 - (2) the ladder or steps shall be surrounded by a barrier which meets the requirements of a barrier.**
- D. Access doors to indoor swimming pools shall be self-closing and self-latching and a second method to warn of unauthorized entrance into the pool.**
- E. In ground spas are less than 8 feet in any dimension. Spas with a cover are exempt from the barrier requirements. The cover must be in place when the spa is not in use. Lap pools and pools greater than 8 feet in any dimension are treated as pools and have the same barrier requirements.**

F. A self-contained, portable above ground spa equipped with an approved locking safety over meeting ASTM Standard ES 13-89 may be exempt from the barrier requirements.

G. All swimming pool and spa water shall be maintained in a clear condition that is free of algae, insects, debris, and in a sanitary condition.

Pool Barrier and Safety Device Details

Definition of a pool is any swimming pool, hot tub, spa or similar outdoor body of water intended for swimming or recreation and is eighteen inches (18") or more in depth located at a single family residence.

Barrier requirements and details

- The top of the enclosure shall be at least sixty inches (60") above grade measured on side of the barrier which faces away from the swimming pool.
- Openings in the enclosure shall not allow passage of a four inch (4") diameter sphere. Shrubs, trees or landscape materials cannot be considered as part of the barrier. The bottom of a fence shall be no more than 2 inches above grade.
- Solid enclosures, such as masonry, concrete or stone walls shall not contain indentations, protrusions or plants closer than forty-five inches (45") apart vertically, horizontally, or from top of wall, except for tooled masonry joints.
- Any configuration providing ladder-like access allowing unauthorized entry to the pool area shall be prohibited. Ladder-like access shall mean any method or action such as climbing, crawling, pushing, jumping or other means to gain access to a pool or spa area.
- Where the barrier is composed of horizontal and vertical members, the distance between the tops of the horizontal members shall be forty-five inches (45") or more. Openings between vertical members shall not exceed four inches (4").
- Maximum mesh size for chain link fences shall be two and one-quarter inches (2¼") unless the fence is provided with slats fastened at the top or the bottom which reduce the openings to not more than one and three-quarter inches (1¾"). The wire shall not be less than 9 gauge.
- Where the barrier is composed of diagonal members, such as a lattice fence, the maximum opening formed by the diagonal members shall be no more than one and three-quarter inches (1¾").
- All access gates shall open outward away from the pool, spa or hot tub and shall be self-closing and have a self-latching device. Where the release mechanism of the self-latching device is located less than fifty-four inches (54") from the bottom of the gate or adjoining grade,
 - (1) the release mechanism shall be located on the pool side of the gate at least three inches below the top of the gate, and
 - (2) the gate and barrier shall have no opening greater than one-half inch (1/2") within twenty-four inches (24") of the release mechanism.

Above Ground pool



Removable fence with gate



Automatic pool cover

Pool entry alarm, may be sonic, laser or other approved device

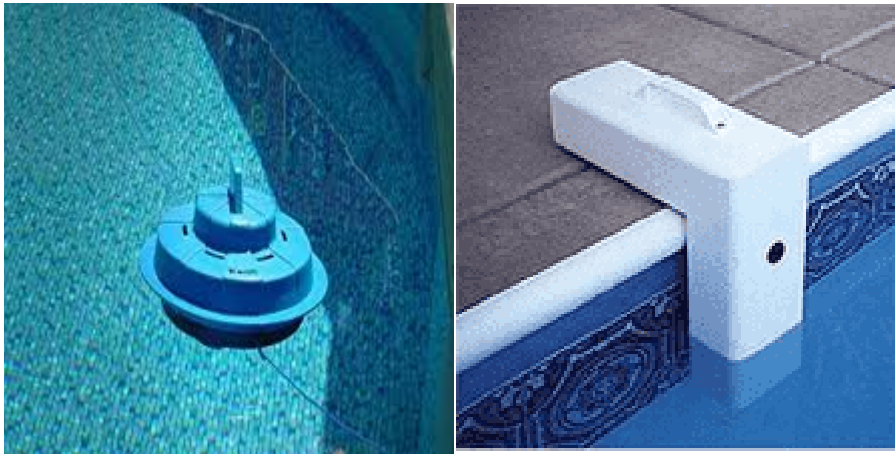

A compliant pool barrier fence.



Below is a non-compliant barrier fence. The horizontal members must be 45 inches apart to prevent a climbable condition.





POLLUTION PREVENTION FOR CONSTRUCTION

BI-27

All construction projects regardless of size are required, at a minimum, to implement an effective combination of erosion and sediment control methods and follow Best Management Practices (BMP's) during the construction process.

Construction sites need to follow good housekeeping practices in order to prevent pollutants from entering the storm drains.

Typical construction site issues to address include:

- Stockpile Management
- Concrete & Mortar Waste Management
- Solid Waste Management
- Sanitary / Septic Waste Management
- Hazardous Materials - Delivery, Storage & Use

***MUST BE IMPRINTED ON ALL NEW CONSTRUCTION/ADDITION PLANS

3.2 Minimum Requirements

All construction projects regardless of size are required, at a minimum, to implement an effective combination of erosion and sediment controls and waste and materials management Best Management Practices. These minimum requirements are summarized in Table 3-2 and must be conveyed to construction contractors as part of the plan notes or on a separate erosion control plan as required by the agency.

Table 3-2
Minimum Requirements for All Construction Sites

Category	Minimum Requirements
Erosion and Sediment Control	Sediments from areas disturbed by construction shall be retained on site using an effective combination of erosion and stockpiles of soil shall be properly contained to minimize sediment transport from the site to streets, drainage facilities or adjacent properties via runoff, vehicle tracking, or wind.
Waste and Materials Management Control	Construction-related materials, wastes, spills or residues shall be retained on site to minimize transport from the site to streets, drainage facilities, or adjoining property by wind or runoff.



BMPs: Easy Solutions for Keeping Our Ocean Waters Clean

Best Management Practices (BMPs) are activities such as good housekeeping practices, pollution prevention techniques, educational practices and maintenance procedures. Many BMPs are easy and inexpensive. Construction sites should follow the tips below to prevent pollutants from entering storm drains in the first place, and help protect our environment, our families' health and safety and our local economy.

Stockpile Management:

- Protect all stockpiles from storm water run-on using temporary perimeter sediment barriers such as berms, dikes, fiber rolls, silt fences, sand or gravel bags, or straw bale barriers.
- During the rainy season, stock piles must be covered and have a temporary sediment barrier at all times.
- During the non rainy season, stockpiles must be covered at the end of each work day and have a temporary sediment barrier at all times. Implement wind control practices as appropriate.

Concrete Waste Management:

- When obtaining ready mix concrete from a supplier, discuss their BMP procedures such as handling of concrete waste and washout before deliveries are made.
- Avoid mixing excess amounts of fresh concrete on-site.
- Perform washout of concrete trucks off site or in designated areas only and never wash out concrete trucks on the street or into storm drains, open ditches, or streams
- Never wash any concrete products including dust and silt down into the gutter or storm drain. Always monitor on-site concrete tasks, such as saw cutting, coring, grinding, and grooving to ensure proper methods are implemented.
- Concrete cutting residue should be vacuumed and never allowed to flow across pavement or left on the surface of pavement.
- A sign should be installed adjacent to each wash out facility to inform concrete equipment operators to utilize the proper facilities.
- Wash out only from mixer truck shoots into concrete washout.
- Concrete washout from concrete pumper bins can be washed out into pumper trucks and discharged into designated washout area or properly disposed of off site.
- Once concrete wastes are washed into the designated area and allowed to harden, the concrete should be broken up, removed, and properly disposed of.

Solid Waste Management:

- Select designated waste collection areas on site and locate containers in a covered area and / or in a secondary containment. Be sure to have enough conveniently located containers throughout the project.
- Collect site refuse daily, especially during rainy / windy conditions and plan for an adequate number of pickups. Never overfill a dumpster.
- Remove refuse promptly from all erosion and sediment control devices as well as storm drains.
- Always make sure that toxic liquids and chemicals are never disposed of in dumpsters designated for construction debris. Liquid and hazardous wastes must always be disposed of properly.
- Do not hose out dumpsters on the construction site. Leave dumpster cleaning to the refuse hauler.
- Recycle or salvage as much construction and demolition debris as possible.

Sanitary / Septic Waste Management

- Use only reputable, licensed sanitary / septic waste haulers.

- Temporary sanitary facilities must be located in a convenient location away from drainage facilities, watercourses, as well as traffic and should always have secondary containment.
- Untreated raw wastewater must never overflow, be discharged or buried within the project site.
- Be sure to have enough restrooms conveniently located throughout the project.

Hazardous Material Delivery and Storage:

- Minimize storage of hazardous materials onsite, and consider storage in a covered area.
- Store materials in a designated area on pallets with secondary containment (Earth Dikes, Drainage Swales, or Lined Ditches) away from traffic, waterways, and storm drains.
- Keep ample supply of appropriate spill clean up material near storage areas.
- Conduct regular weekly inspections as well as before and after any rain events. Train employees and subcontractors.
- Be able to supply Material Safety Data Sheets (MSDS) for all materials stored and keep an accurate, up to date inventory of materials delivered and stored on site.
- Storage of reactive, ignitable or flammable liquids must comply with fire codes.
- Those trained in emergency spill cleanups must be present when dangerous materials are unloaded.
- Contain and clean up any spill immediately.
- Clean spills on dirt areas by digging up and properly disposing of the contaminated soil.

Hazardous Material Use:

- Minimize use as much as possible
- Follow manufacture instructions regarding uses, mixing, conditions, and warnings of chemicals.
- Never over apply and prepare only the amount needed.
- Never apply any chemicals immediately before a rain event, and always use the entire product before disposing the container.
- Never clean tools, paintbrushes, or rinse containers into a street, gutter, storm drain, or watercourse and always dispose of any hazardous chemicals / materials as hazardous waste.
- Use recycled and less hazardous products whenever practical.
- Non-toxic liquid wastes such as latex paints may be collected in a lined collection area. This area must be properly bermed and kept covered during rain events and at the end of every work day and must never be allowed to overflow or to be disposed of to uncovered ground.
- Liquid and hazardous wastes must always be disposed of appropriately.
- **Immediately report any significant spills to the County’s 24-hour water pollution reporting hotline at 714-567-6363 or the City of San Clemente’s 24 hour hot line at 949-366-1553.**

Routinely train all employees and require any contractors / sub-contractors to follow these BMPs.

Acknowledgement:

I _____(print name) certify that I have read the preceding document regarding construction site Best Management Practices (BMPs). I have been informed that these basic BMPs must be implemented and maintained on all construction sites, and that the City may impose fines or other civil or criminal sanctions against me or my business for allowing runoff and construction debris to enter the storm drain system. I take full responsibility for maintaining basic BMPs on construction sites for which I am accountable.

Contractor Signature

Date