



AGENDA REPORT

CITY OF SAN CLEMENTE

CITY COUNCIL MEETING

910 Calle Negocio
2nd Floor
San Clemente, California
www.san-clemente.org

Meeting Date: April 16, 2024

Agenda Item: 100

Submitted By: Public Works
Prepared By: Amir Ilkhanipour, Principal Civil Engineer

Subject:
CONSIDERATION OF A RESOLUTION TO ACCEPT AND FILE A NOTICE OF COMPLETION FOR THE PARK MONUMENT SIGN REPLACEMENT PROGRAM (AUGUST 2023), MAX BERG PLAZA AND MARBLEHEAD PARKS, CIP PROJECT NO. 29103

Fiscal Impact:
The total construction cost of \$82,390 was within the approved construction budget of \$94,090 from the General Fund, Account No. 001-635-45700-000-29103, Park Monument Sign Replacement Program.

Summary:
Before the City Council is a resolution and Notice of Completion (Attachment 2) for the Park Monument Sign Replacement Program (August 2023), Max Berg Plaza and Marblehead Parks, as shown on the Location Map (Attachment 1).

Background:
On October 3, 2023, the City Council awarded a construction contract to A&D Signs Corporation dba America’s Instant Signs to replace park monument signs at Max Berg Plaza and Marblehead Parks, as part of the Master Wayfinding Sign Program (Attachment 3).



A summary of the total construction expenditures is provided below:

Construction Administration, Management & Inspection:	\$15,500
Construction Contract:	\$66,890
Total Construction Cost	\$82,390

Council Options:

- Adopt Resolution No. 24-61 (Attachment 4), which would accept the completed construction work for the Park Monument Sign Replacement Program (August 2023), Max Berg Plaza and Marblehead Parks.
- Adopt Resolution No. 24-61 with modifications.
- Continue the item with direction to provide additional information.

Environmental Review/Analysis:

Acceptance and filing of a notice of completion is not a project pursuant to the California Environmental Quality Act (CEQA). The work undertaken was previously determined to be categorically exempt from CEQA under Class 2 of the State CEQA Guidelines, Section 15302 – Replacement of Existing Facilities. A notice of exemption was filed with the County of Orange Recorder’s Office on June 10, 2021 for this project (Attachment 5).

Recommended Actions:

Staff recommends that the City Council adopt Resolution No. 24-61, which will:

1. Accept the Park Monument Sign Replacement Program (August 2023), Max Berg Plaza and Marblehead Parks, CIP Project No. 29103, from A&D Signs Corporation dba America’s Instant Signs.
2. Authorize the Public Works Director to execute and record the Notice of Completion for the Park Monument Sign Replacement Program (August 2023), Max Berg Plaza and Marblehead Parks, CIP Project No. 29103.
3. Authorize the City Clerk to release the payment bond 35 days from the recordation of the Notice of Completion upon verification with the Engineering Division that no liens have been levied against the Contractor, A&D Signs Corporation dba America’s Instant Signs.

Attachment:

1. Location Map
2. Notice of Completion
3. Staff Report dated October 3, 2023
4. Resolution 24-61
5. Notice of Exemption

Notification:

None

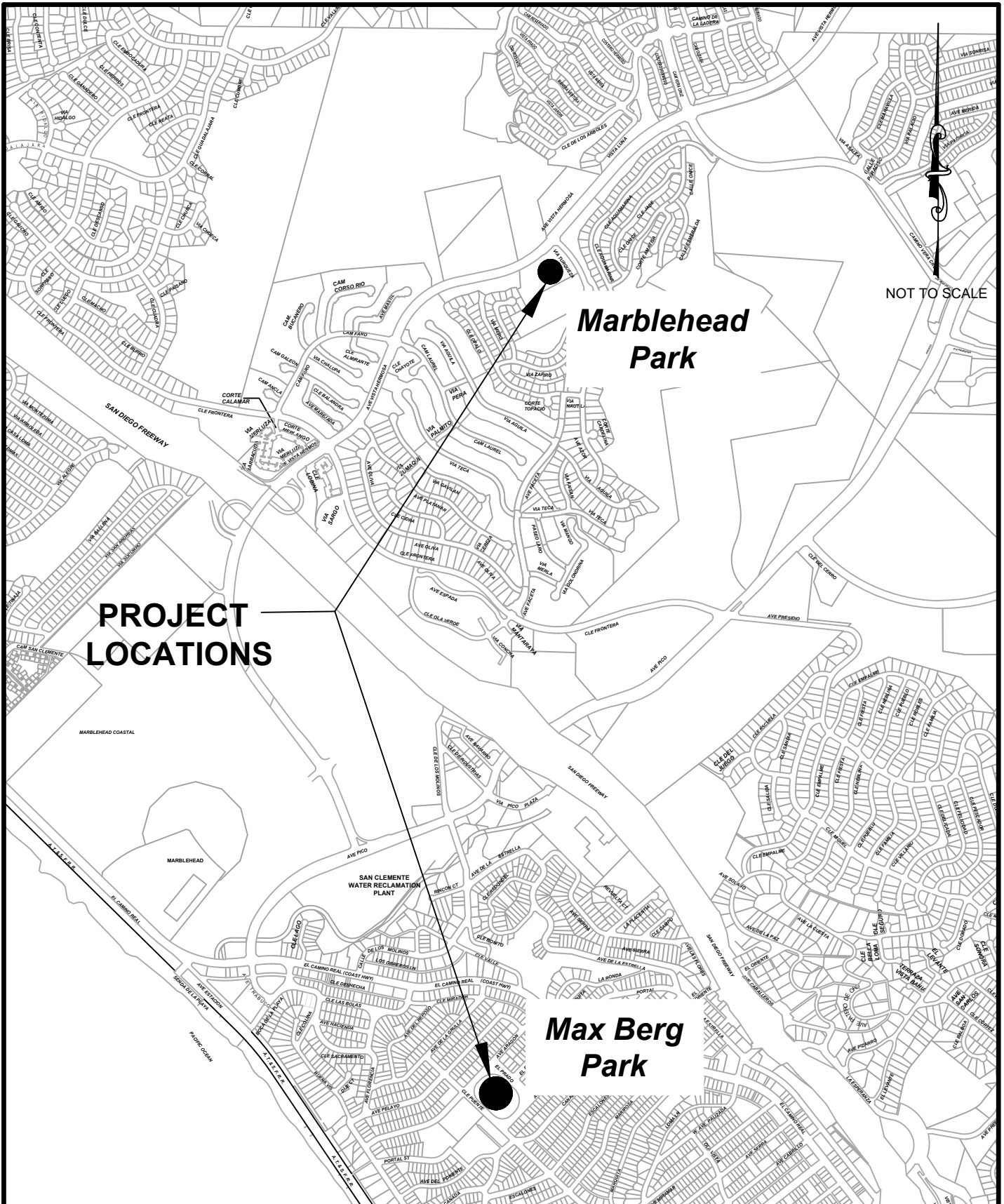

PROJECT LOCATIONS

Marblehead Park

Max Berg Park

NOT TO SCALE

S:\public\CMMS\GIS\Users\Joke Ohana\CAD\Location Plan (Admin Report).dwg Wednesday, September 20, 2023 11:02:56 AM



City of San Clemente

910 Calle Negocio, Suite 100
San Clemente, CA 92673
Tel (949) 361-6100
Fax (949) 361-8316

LOCATION MAP
Park Monument Sign
Replacement - August 2023

PN 29103

Recording Requested By:
City of San Clemente

When Recorded, Mail To:
Public Works Department
City of San Clemente
910 Calle Negocio
San Clemente, CA 92673

Recorded for the benefit of the City of San Clemente and exempt from recording fees pursuant to Government Code Section 27383.

Space above this line is for Recorder's Use Only

NOTICE OF COMPLETION

Notice is hereby given by the City of San Clemente, a Municipal Corporation, that a public work of improvement has been completed as follows:

- 1. *Project title or description of work:* Park Monument Sign Replacement Program (August 2023), Max Berg Plaza and Marblehead Parks
- 2. *Date of completion:* March 26, 2024
- 3. *Street address or legal description of the project site:* Max Berg Plaza Park and Marblehead Park, San Clemente, CA 92672
- 4. *Name of owner:* City of San Clemente
- 5. *Interest or estate of owner:* Fee ownership
- 6. *Address of owner:* 910 Calle Negocio, San Clemente, CA 92673
- 7. *Name and address of contractor:* A&D Signs Corporation dba America's Instant Signs, 1260 N. Hancock Street, Unit 106, Anaheim, CA, 90631

I am the Public Works Director/City Engineer for the City of San Clemente, a Municipal Corporation, the owner of the indicated interest or estate in the property described above. I make this verification on behalf of the City of San Clemente. I have read this Notice of Completion and know its contents. I declare under penalty of perjury under the laws of the State of California that the foregoing is true and correct.

Executed on _____ in San Clemente, California.

David Rebensdorf, Public Works Director/City Engineer
City of San Clemente



AGENDA REPORT

CITY OF SAN CLEMENTE

CITY COUNCIL MEETING

910 Calle Negocio
2nd Floor
San Clemente, California
www.san-clemente.org

Meeting Date: October 3, 2023

Agenda Item: 7M

Department: Public Works

Prepared By: Amir K. Ilkhanipour, Principal Civil Engineer

Subject:

CONSIDERATION OF A RESOLUTION AWARDING A CONSTRUCTION CONTRACT TO A&D SIGNS CORP DBA AMERICA'S INSTANT SIGNS FOR THE PARK MONUMENT SIGN REPLACEMENT PROGRAM (AUGUST 2023), CIP PROJECT NO. 29103; AUTHORIZING THE CITY MANAGER TO EXECUTE A CONTRACT IN AN AMOUNT NOT TO EXCEED \$62,790

Fiscal Impact:

Yes. The estimated construction cost of \$94,090 is within the approved budget of \$199,349 from the General Fund, Account No. 001-635-45700-000-29103, Park Monument Sign Replacement Program.

Summary:

As part of the Master Wayfinding Program, two park monument signs at Max Berg Plaza and Marblehead Parks are being replaced.

Before the City Council is the approval of a construction contract (Attachment 2) with A&D Signs Corp dba America's Instant Signs, in an amount of not to exceed \$62,790, plus a 10% project contingency of \$6,300, for replacing two park monument signs, from the General Fund, Account No. 001-635-45700-000-29103.

Background:

On February 16, 2010, the City Council adopted Resolution No. 10-11 (Attachment 3) which approved the conceptual Master Wayfinding Sign Program. The goal of the Sign Program was to create a uniform sign program that reflects the City's Spanish Village by the Sea character. On March 16, 2021, the City Council received and filed a plan design for park monument sign replacements, consistent with the City's Wayfinding Sign Program (Attachment 4). In 2021, two park monument signs were replaced in Verde Park and Bonita Canyon Park. The next phase of proposed sign replacements are Max Berg Plaza and Marblehead Parks. Future park sign replacements are scheduled as part of the City's Capital Improvement Program for approximately \$150,000 each fiscal year through 2028, subject to available funding.

City staff and Michael Baker International prepared a bid package for replacing the wooden park monument signs at the Max Berg Plaza and Marblehead Parks. These wooden signs were removed due to their deteriorated condition. The project was advertised for competitive bidding on the PlanetBids website and bids were received on August 31, 2023. While local contractors were notified of the bid advertising, no local contractors submitted bids. Bids ranged from \$62,790 to \$169,800, as shown on the Bidders' Listing (Attachment 5). The lowest responsive bidder was A&D Signs Corp dba America's Instant Signs, of Anaheim, California with a total bid of \$62,790.

Based on the low bid, construction costs are estimated as follows:

Construction Administration and Management, Inspection and materials testing	\$ 25,000
Construction Contract	62,790
<u>Contingency (10%)</u>	<u>6,300</u>
Total Estimated Construction Cost:	\$ 94,090

As required by the City policy and state law, the Contractor will be required to provide performance and payment bonds simultaneously with execution of the construction contract (Attachment 3). Project plans and specifications are on file in the City Clerk's office.

Council Options:

- Adopt Resolution No. 23-112 (Attachment 6), awarding the contract for the Park Monument Sign Replacement Program (August 2023) to A&D Signs Corp dba America's Instant Signs, authorizing the City Manager to execute the construction contract in an amount not to exceed \$62,790, and approving a 10% project contingency of \$6,300, from the General Fund, Account No. 001-635-45700-000-29103, Park Monument Sign Replacement Program.
- Modify and adopt Resolution No. 23-112.
- Do not adopt Resolution No. 23-112 and postpone or discontinue the Program.
- Continue the item and direct staff to provide additional information.

Environmental Review/Analysis:

This project is categorically exempt from the California Environmental Quality Act (CEQA) as it pertains to replacement of existing park monument signs under Class 2 of the State CEQA Guidelines, Section 15302 – Replacement of Existing Facilities. A notice of exemption was filed with the County of Orange Recorder's Office on June 10, 2021 for this project (Attachment 7).

Recommended Actions:

Staff Recommendation

Staff recommends that the City Council adopt Resolution No. 23-112, which will:

1. Award the Park Monument Sign Replacement Program (August 2023), CIP Project No. 29103, construction contract to A&D Signs Corp dba America's Instant Signs as the lowest responsible and responsive bidder;
2. Authorize the City Manager to execute a construction contract with A&D Signs Corp dba America's Instant Signs in an amount not to exceed \$62,790, in a form substantially similar to Contract No. C23-58; and
3. Approve a 10% project contingency of \$6,300.

Attachment:

1. Location Map
2. Draft Construction Contract C23-58
3. Resolution No. 10-11
4. Staff Report dated March 16, 2021
5. Bidders' Listing
6. Resolution 23-112
7. Notice of Exemption

Notification:

All bidders.

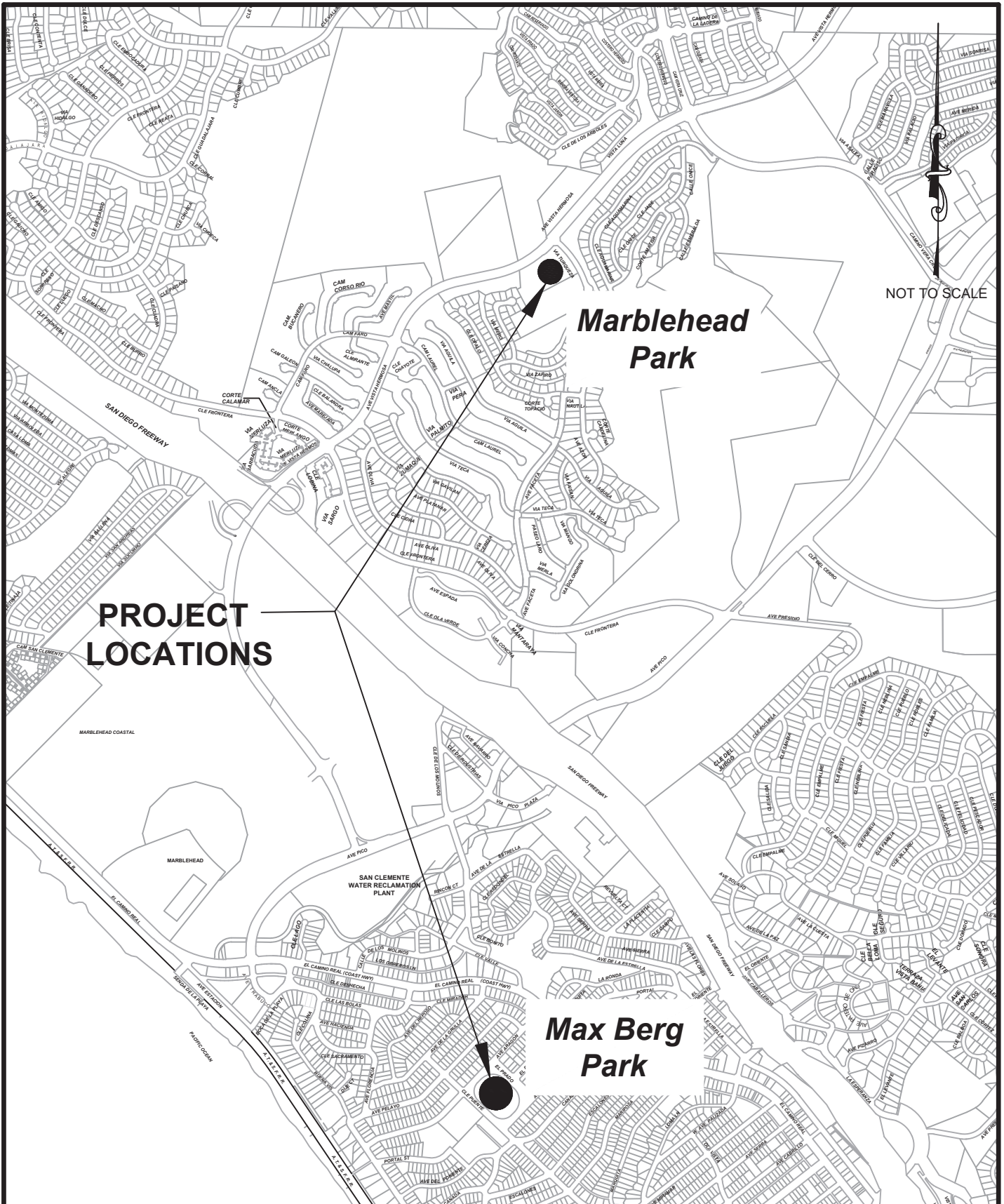

PROJECT LOCATIONS

Marblehead Park

Max Berg Park

NOT TO SCALE

S:\public\CMMS\GIS\Users\Joke Ohana\CAD\Location Plan (Admin Report).dwg Wednesday, September 20, 2023 11:02:56 AM



City of San Clemente
 910 Calle Negocio, Suite 100
 San Clemente, CA 92673
 Tel (949) 361-6100
 Fax (949) 361-8316

LOCATION MAP
Park Monument Sign
Replacement - August 2023
PN 29103

SECTION 00500 CONTRACT

THIS CONTRACT is made this _____ day of _____, 2023, in the County of Orange, State of California, by and between the City of San Clemente hereinafter called City, and A&D Signs Corp dba America's Instant Signs, hereinafter called Contractor. City and the Contractor for the considerations stated herein agree as follows:

ARTICLE 1. SCOPE OF WORK. The Contractor shall perform all Work within the time stipulated the contract and shall provide all labor, materials, equipment, tools, utility services, and transportation to complete all of the Work required in strict compliance with the Contract Documents as specified in Article 5 below for the following Project:

PARK MONUMENT SIGN REPLACEMENT PROGRAM, PROJECT NO. 29103 – August 2023

The Contractor and its surety shall be liable to City for any damages arising as a result of the Contractor's failure to comply with this obligation.

ARTICLE 2. TIME FOR COMPLETION. The Work shall be commenced on the date stated in City's Notice to Proceed. The Contractor shall complete all Work required by the Contract Documents within fifty (50) working days from the commencement date stated in the Notice to Proceed. By its signature hereunder, Contractor agrees the time for completion set forth above is adequate and reasonable to complete the Work.

ARTICLE 3. CONTRACT PRICE. City shall pay to the Contractor as full compensation for the performance of the Contract, subject to any additions or deductions as provided in the Contract Documents, and including all applicable taxes and costs, the sum of Sixty-Two Thousand, Seven Hundred and Ninety Dollars (\$62,790). Payment shall be made as set forth in the General Conditions.

At any time during the term of the Contract, City may, pursuant to the terms and provisions of the Contract Documents, request that the Contractor perform additional work. Contractor shall not perform, nor be compensated for, additional work without written authorization from the City pursuant to the terms and provisions of the Contract Documents.

ARTICLE 4. LIQUIDATED DAMAGES/EARLY COMPLETION INCENTIVE. In accordance with Government Code section 53069.85, it is agreed that the Contractor will pay City the sum of \$1,000 for each and every calendar day of delay beyond the time prescribed in the Contract Documents for finishing the Work, as Liquidated Damages and not as a penalty or forfeiture. In the event that Liquidated Damages are not paid, the Contractor agrees City may deduct that amount from any money due or that may become due the Contractor under the Contract. This Article does not exclude recovery of other damages specified in the Contract Documents.

ARTICLE 5. COMPONENT PARTS OF THE CONTRACT. The "Contract Documents" include the following:

Notice Inviting Bids
Instructions to Bidders
Bid Form

SECTION 00500
CONTRACT

Contractor's Certificate Regarding Workers' Compensation
Bid Bond
Designation of Subcontractors
Information Required of Bidders
Noncollusion Declaration form
Iran Contracting Act Certification
Public Works Contractor Registration Certification
Contract
Performance Bond
Payment Bond
General Conditions
Special Conditions
Technical Specifications
Addenda
Plans and Drawings
Approved and fully executed change orders
Any other documents contained in or incorporated into the Contract

The Contractor shall complete the Work in strict accordance with all of the Contract Documents.

All of the Contract Documents are intended to be complementary. Work required by one of the Contract Documents and not by others shall be done as if required by all. This Contract shall supersede any prior agreement of the parties.

ARTICLE 6. PROVISIONS REQUIRED BY LAW. Each and every provision of law required to be included in these Contract Documents shall be deemed to be included in these Contract Documents. The Contractor shall comply with all requirements of applicable federal, state and local laws, rules and regulations, including, but not limited to, the provisions of the California Labor Code and California Public Contract Code which are applicable to this Project.

ARTICLE 7. INDEMNIFICATION. Contractor shall provide indemnification as set forth in the General Conditions.

ARTICLE 8. PREVAILING WAGES. Contractor shall be required to pay the prevailing rate of wages in accordance with the Labor Code which such rates shall be made available at City of San Clemente Public Works Department Office at 910 Calle Negocio, San Clemente, CA 92673 or may be obtained online at <http://www.dir.ca.gov/dlsr> and which must be posted at the job site.

IN WITNESS WHEREOF, this Contract has been duly executed by the above-named parties, on the day and year above written.

IN WITNESS WHEREOF, the parties hereto have caused this Agreement to be duly executed on the respective dates set forth opposite of their signatures.

CITY OF SAN CLEMENTE

By: _____

Andy Hall, City Manager

Dated: _____, 20____

ATTEST:

City Clerk of the City of San Clemente, California

APPROVED AS TO FORM:

Elizabeth A. Mitchell, City Attorney

**APPROVED AS TO AVAILABILITY
OF FUNDING:**

Finance Authorization

A&D Signs Corp dba America's Instant Signs
("CONTRACTOR")

By: _____
ANSHUL VASWANEY

Its: Chief Executive Officer

Dated: _____, 20____

A&D Signs Corp dba America's Instant Signs
("CONTRACTOR")

By: _____
DIPALI NANDA

Its: Secretary

Dated: _____, 20____

END OF CONTRACT



SECTION 00100
NOTICE INVITING BIDS

PARK MONUMENT SIGN REPLACEMENT PROGRAM
Project No. 29103 – August 2023

1. **Notice.** Public notice is hereby given that the City of San Clemente (“City”) will receive sealed bids for the following project:

PARK MONUMENT SIGN REPLACEMENT PROGRAM
PROJECT NO. 29103 – August 2023

2. Electronic bids must be submitted **prior to 2:00 p.m. on Thursday, August 31, 2023**, on the City’s PlanetBids System Vendor Portal, at which time or thereafter bids will be opened and made available online. Bids received after this time will be considered non-responsive. Prospective bidders must first register as a vendor and then bid on this project via the City’s PlanetBids System Vendor Portal website at www.san-clemente.org/vendorbids.
3. **Project Scope of Work.** This project involves the replacement of existing park entry sign as reflected in this project plans. The proposed entry monument sign reflects the park name using aluminum lettering attached to a masonry block wall and supported on a concrete spread footing. The location of the entry monument signs to be replaced will be provided by the City of San Clemente.
4. **Contract Time:** The work must be completed within fifty (50) working days from the date specified in the written Notice to Proceed.
5. **License and Registration Requirements.**
 - 5.1. **State License.** Pursuant to California Public Contract Code Section 3300, the City has determined that the Contractor shall possess a valid California contractor’s license for the following classification: Class “A”, “B” or “C” (if relevant to the work to be performed). Failure to possess the specified license(s) at the time of bid opening shall render the bid as non-responsive and shall act as a bar to award the contract to that non-responsive bidder.
 - 5.2. **Department of Industrial Relations Registration.** Pursuant to California Labor Code Sections 1725.5 and 1771.1, all contractors and subcontractors that wish to bid on, be listed in a bid proposal, or enter into a contract to perform public work must be registered with the Department of Industrial Relations (“DIR”). No bid will be accepted nor any contract entered into without proof of the contractor’s and subcontractors’ current registration with the DIR to perform public work. If awarded a contract, the Bidder and its subcontractors, of any tier, shall maintain active registration with the DIR for the duration of the Project.
 - 5.3. **City Business License.** Prior to the Notice to Proceed for this contract, the Contractor shall possess a valid City of San Clemente business license.
6. **Contract Documents.** Bid documents, including instructions to bidders, bidder proposal form, and specifications (not including other documents incorporated by reference) may be

SECTION 00100
NOTICE INVITING BIDS

downloaded, at no cost, from the City's PlanetBids System Vendor Portal website at www.san-clemente.org/vendorbids. Bidders must first register as a vendor on the City of San Clemente PlanetBids system to view and download the Contract Documents, to be added to the prospective bidders list, and to receive addendum notifications when issued.

7. Bid Proposal and Security.

7.1. **Bid Proposal Form.** No bid will be received unless it is made on a proposal form furnished by the City. Bidders must complete line items information (PlanetBids Line Items Tab), and attach a scanned copy of the paper Bid Form (SECTION 00400), Bid Bond (SECTION 00410), Non-Collusion Declaration (SECTION 00420), Contractor Information and Experience Form (SECTION 00430), List of Subcontractors Form (SECTION 00440), Iran Contracting Act Certification (SECTION 00450), Public Works Contractor Registration Certification (SECTION 00460) completed and uploaded in the PlanetBids "Attachments" Tab.

7.2. **Bid Security.** Each bid proposal must be accompanied by security in the form of cash, certified check, cashier's check, or bid bond in the amount of ten percent (10%) of the total bid amount. Personal checks or company checks are not acceptable forms of bid security. All certified and cashier's checks must be drawn on a responsible bank doing business in the United States and shall be made payable to THE CITY OF SAN CLEMENTE. Bid bonds must be issued by a surety company licensed to do business in the State of California and must be made payable to THE CITY OF SAN CLEMENTE. Bids not accompanied by the required bid security will be rejected. For electronic submittal of bids, the bid security must be received at the City of San Clemente Public Works office, 910 Calle Negocio, San Clemente, CA 92673 within 24 hours after the bid opening date and time. The bid security must be submitted in a sealed envelope bearing the name and address of the bidder, and the outside of the envelope must read as follows:

OFFICIAL BID SECURITY - DO NOT OPEN
PARK MONUMENT SIGN REPLACEMENT PROGRAM
Project No. 29103 – August 2023
Bid Opening Date: *Thursday, August 31, 2023, prior to 2:00 p.m.*

The bid security shall serve as a guarantee that the bidder will enter into a contract. Such guarantee shall be forfeited should the bidder to whom the contract is awarded fail to enter into the contract within 15 calendar days after written notification that the contract has been awarded to the successful bidder.

8. Prevailing Wage Requirements.

8.1. **General.** This project is subject to the prevailing wage requirements applicable to the locality in which the work is to be performed for each craft, classification or type of worker needed to perform the work, including employer payments for health and welfare, pension, vacation, apprenticeship and similar purposes.

8.2. **Rates.** Prevailing rates are available online at www.dir.ca.gov/DLSR and also available at the City of San Clemente Public Works Department Office at 910 Calle Negocio, San Clemente, CA 92673. Each Contractor and Subcontractor must pay no less than the specified rates to all workers employed to work on the project. The schedule of per diem

SECTION 00100
NOTICE INVITING BIDS

wages is based upon a working day of eight hours. The rate for holiday and overtime work must be at least time and one-half.

8.3. Compliance Monitoring. Pursuant to California Labor Code Section 1771.4, all bidders are hereby notified that this project is subject to compliance monitoring and enforcement by the California Department of Industrial Relations. In bidding on this project, it shall be the Bidder's sole responsibility to evaluate and include the cost of complying with all labor compliance requirements under this contract and applicable law in its bid.

9. Retention. Pursuant to the contract for this project, five percent (5%) of each progress payment will be retained as security for completion of the balance of the work.

Substitution of appropriate securities in lieu of retention amounts from progress payments is permitted pursuant to California Public Contract Code Section 22300. Refer to the contract for further clarification.

10. Performance and Payment Bonds. The successful bidder, simultaneously with execution of the contract, will be required to provide Faithful Performance and Labor and Material Payment Bonds, each in the amount of one hundred percent (100%) of the contract amount. Bonds are to be secured from a surety that meets all of the State of California bonding requirements, as defined in Code of Civil Procedure Section 995.120, and is admitted by the State of California.

11. Pre-Bid Meeting. A pre-bid meeting will be held on Thursday, August 17, 2023 for this bid solicitation at 10:00 A.M. at the Max Berg Plaza Park project location. Following this meeting there will be a visit to the other project site at Marblehead Park. Refer to the Instructions to Bidders section on how to submit any pre-bid questions.

12. Not Used

13. Instructions to Bidders. Additional and more detailed information is provided in the Instructions to Bidders, which should be carefully reviewed by all bidders before submitting a Bid Proposal.

14. Questions. All questions related to this bid solicitation must be submitted in writing via email to Amir K. Ilkhanipour at ilkhanipoura@san-clemente.org no later than 2:00 p.m. on Tuesday, August 22, 2023.

THE CITY OF SAN CLEMENTE RESERVES THE RIGHT TO REJECT ANY AND ALL BIDS, TO AWARD ALL OR ANY INDIVIDUAL PART/ITEM OF THE BID, AND TO WAIVE ANY INFORMALITIES, IRREGULARITIES OR TECHNICAL DEFECTS IN SUCH BIDS OR IN THE BIDDING PROCESS. ANY CONTRACT AWARDED WILL BE LET TO THE LOWEST RESPONSIVE AND RESPONSIBLE BIDDER AS DETERMINED FROM THE BASE BID ALONE.

Dated: July 20, 2023.

City of San Clemente Public Works Department
910 Calle Negocio
San Clemente, CA 92673

SECTION 00100
NOTICE INVITING BIDS

END OF NOTICE INVITING BIDS

**SECTION 00200
INSTRUCTIONS TO BIDDERS**

1. AVAILABILITY OF CONTRACT DOCUMENTS

Contract documents (excluding documents incorporated by reference) may be downloaded, at no cost, from the City's PlanetBids System Vendor Portal website at www.san-clemente.org/vendorbids. Bidders must first register as a vendor on the City of San Clemente PlanetBids system to view and download the Contract Documents, to be added to the prospective bidders list, and to receive addendum notifications when issued.

2. EXAMINATION OF CONTRACT DOCUMENTS

City has made copies of the Contract Documents available, as indicated above. Bidders shall be solely responsible for examining the Project Site and the Contract Documents, including any Addenda issued during the bidding period, and for informing itself with respect to local labor availability, means of transportation, necessity for security, laws and codes, local permit requirements, wage scales, local tax structure, contractors' licensing requirements, availability of required insurance, and other factors that could affect the Work. Bidders are responsible for consulting the standards referenced in the Contract. Failure of Bidder to so examine and inform itself shall be at its sole risk, and no relief for error or omission will be given except as required under State law.

3. INTERPRETATION OF CONTRACT DOCUMENTS

Discrepancies in, and/or omissions from the Plans, Specifications or other Contract Documents or questions as to their meaning shall be immediately brought to the attention of City by submission of a written request for an interpretation or correction to City. Such submission, if any, must be submitted no later than 2:00 p.m. on Tuesday, August 22, 2023. Any inquiries received after this deadline will not be accepted. Questions must be submitted in writing to: Amir K. Ilkhanipour via email at ilkhanipoura@san-clemente.org. Phone calls and faxes will not be accepted.

If the City determines that the point in question is substantive and is not clearly and fully set forth in the Contract Documents, the City will issue a written addendum clarifying the matter which will be posted on the City's PlanetBids System Vendor Portal website at www.san-clemente.org/vendorbids. Any interpretation of the Contract Documents will be made only by written addenda posted on the City's PlanetBids system. City will not be responsible for any explanations or interpretations provided in any other manner. No person is authorized to make any oral interpretation of any provision in the Contract Documents to any bidder, and no bidder should rely on any such oral interpretation.

Bids shall include complete compensation for all items that are noted in the Contract Documents as the responsibility of the Contractor.

4. INSPECTION OF SITE; PRE-BID CONFERENCE AND SITE WALK

Each prospective bidder is responsible for fully acquainting itself with the conditions of the Project Site (which may include more than one site), as well as those relating to the construction and labor of the Project, to fully understand the facilities, difficulties and restrictions which may impact the cost or effort required to complete the Project. No Pre-Bid Conference or Site Walk will be

SECTION 00200
INSTRUCTIONS TO BIDDERS

held for this project. Storm, surface, nuisance, or other waters may be encountered at various times during construction of the Project. Federal and State laws require the City and its contractors to appropriately manage such waters pursuant to the requirements of California State Water Resources Control Board Order Number 2009-0009-DWQ and any amendment or renewal thereof, the Federal Clean Water Act, and the California Porter Cologne Water Quality Control Act. By submitting a Bid, each bidder acknowledges that it has investigated the risk arising from such waters, has prepared its Bid accordingly, and assumes any and all risks and liabilities arising therefrom.

5. ADDENDA

Substantive City changes to the requirements contained herein will be made by written addendum to this Invitation for Bids. Any written addenda issued pertaining to this Invitation for Bids will be posted on the City's PlanetBids System Vendor Portal website at www.san-clemente.org/vendorbids, and will be incorporated into the terms and conditions of any resulting Purchase Order and/or Contract as appropriate. The City shall not be bound to any modifications to or deviations from the requirements set forth in this Invitation for Bids as the result of oral instruction or communication.

Pursuant to Public Contract Code Section 4104.5, if City issues an Addendum which includes material changes to the Project less than 72 hours prior to the deadline for submission of bids, City will extend the deadline for submission of bids. City may determine, in its sole discretion, whether an Addendum warrants postponement of the bid submission date.

6. ALTERNATE BIDS

If alternate bid items are called for in the Contract Documents, the lowest bid will be determined on the basis of the base bid only. However, City may choose to award the contract on the basis of the base bid alone or the base bid and any alternate or combination of alternates. The time required for completion of the alternate bid items has been factored into the Contract duration and no additional Contract time will be awarded for any of the alternate bid items. City may elect to include one or more of the alternate bid items, or to otherwise remove certain work from the Project scope of work, accordingly each Bidder must ensure that each bid item contains a proportionate share of profit, overhead and other costs or expenses which will be incurred by the Bidder.

7. COMPLETION OF BID FORMS

Bids shall only be prepared using copies of the Bid Forms which are included in the Contract Documents. The use of substitute bid forms other than clear and correct photocopies of those provided by City will not be permitted. Bids shall be executed by an authorized signatory as described in these Instructions to Bidders. In addition, Bidders shall fill in all blank spaces (including inserting "N/A" where applicable) and initial all interlineations, alterations, or erasures to the Bid Forms. Bidders shall neither delete, modify, nor supplement the printed matter on the Bid Forms nor make substitutions thereon. USE OF BLACK OR BLUE INK, A TYPEWRITER, OR ELECTRONIC FORMS WITH COMPUTER-FILLABLE FORM FIELDS (IF PROVIDED BY THE

SECTION 00200
INSTRUCTIONS TO BIDDERS

CITY) IS REQUIRED. Deviations in the bid form may result in the bid being deemed non-responsive.

8. MODIFICATIONS OF BIDS

Each Bidder shall submit its Bid in strict conformity with the requirements of the Contract Documents. Unauthorized additions, modifications, revisions, conditions, limitations, exclusions or provisions attached to a Bid may render it non-responsive and may cause its rejection. Bidders shall neither delete, modify, nor supplement the printed matter on the Bid Forms, nor make substitutions thereon. Oral, telephonic and electronic modifications will not be considered, unless the Notice Inviting Bids authorizes the submission of electronic bids and modifications thereto and such modifications are made in accordance with the Notice Inviting Bids.

9. DESIGNATION OF SUBCONTRACTORS

Pursuant to State law, the Bidders must designate the name, license number, and location of each subcontractor who will perform work or render services for the Bidder in an amount that exceeds one half of one percent (1/2%) of the Bidder's Total Bid Price, or \$10,000 if the work involves streets or highways, whichever is greater as well as the portion of work each such subcontractor will perform on the form provided herein by City. No additional time will be provided to bidders to submit any of the requested information in the Designation of Subcontractor form. The successful bidder will be required to self-perform at least over 50% of the work.

In addition to submitting the List of Subcontractors form with its bid submission, each bidder shall, within 24 hours of the bid submission deadline, provide the City with a list of bid items that correspond to the portion of work listed for each designated subcontractor. Failure to provide this information in satisfactory form within the time prescribed may be cause for the City to deem the Bid non-responsive and the City may reject the Bid.

10. LICENSING REQUIREMENTS

Pursuant to Section 7028.15 of the Business and Professions Code and Section 3300 of the Public Contract Code, all bidders must possess proper licenses for performance of this Contract. Subcontractors must possess the appropriate licenses for each specialty subcontracted. Pursuant to Section 7028.5 of the Business and Professions Code, City shall consider any bid submitted by a contractor not currently licensed in accordance with state law and pursuant to the requirements found in the Contract Documents to be non-responsive, and City shall reject the Bid. City shall have the right to request, and Bidders shall provide within five (5) calendar days, evidence satisfactory to City of all valid license(s) currently held by that Bidder and each of the Bidder's subcontractors, before awarding the Contract.

The Contractor and all subcontractors must also obtain a valid City of San Clemente Business License and maintain a valid City Business License during the entire time that work is being performed under the contract. Information about obtaining a City business license is available via Internet at www.san-clemente.org/i-am-a-/business/business-license, by email to businesslicense@san-clemente.org or phone call to (949) 361-6166. Evidence of a valid City business license must be provided at the time specified in Section 19 of these instructions.

13. SUBMISSION OF SEALED BIDS

Bids will only be received electronically through the City's PlanetBids System Vendor Portal website at www.san-clemente.org/vendorbids. Bids will not be accepted after the specified Bid Opening date and time. The Bidder shall have the sole exclusive responsibility for ensuring that a Bid is received by the specified Bid Opening date and time. For technical support with the electronic bidding system, please click the red question mark from any PlanetBids screen to be directed to the technical support help desk.

14. DELIVERY AND OPENING OF BIDS

Bids will only be received electronically through the City's PlanetBids System Vendor Portal website at www.san-clemente.org/vendorbids. Bids will not be accepted after the specified Bid Opening date and time. The Bidder shall have the sole exclusive responsibility for ensuring that a Bid is received by the specified Bid Opening date and time. For technical support with the electronic bidding system, please click the red question mark from any PlanetBids screen to be directed to the technical support help desk.

15. WITHDRAWAL OF BID

Any Bidder may personally withdraw his Bid from the City's PlanetBids system prior to the bid opening date and time stated in the Notice Inviting Bids. Any request to withdraw a bid after bid opening shall meet all requirements of Public Contract Code section 5100 et seq. and must be submitted in writing within five (5) working days, excluding Saturdays, Sundays and State holidays, specifying in detail the mistake.

16. BASIS OF AWARD; BALANCED BIDS

City shall award the Contract to the lowest responsive, responsible Bidder submitting a responsive Bid. City may reject any Bid which, in its opinion when compared to other bids received or to City's internal estimates, does not accurately reflect the cost to perform the Work. City may reject as non-responsive any bid which unevenly weights or allocates costs, including but not limited to overhead and profit to one or more particular bid items.

17. DISQUALIFICATION OF BIDDERS; INTEREST IN MORE THAN ONE BID

No bidder shall be allowed to make, submit or be interested in more than one bid. However, a person, firm, corporation or other entity that has submitted a sub proposal to a bidder, or that has quoted prices of materials to a bidder, is not thereby disqualified from submitting a sub proposal or quoting prices to other bidders submitting a bid to City. No person, firm, corporation, or other entity may submit sub proposal to a bidder, or quote prices of materials to a bidder, when also submitting a prime bid on the same Project.

18. INSURANCE REQUIREMENTS

The successful bidder shall procure the insurance in the form and in the amount specified in the Contract Documents.

19. AWARD PROCESS

Once all Bids are opened and reviewed to determine the lowest responsive and responsible Bidder, City Council may award the contract. The apparent successful Bidder should begin to prepare the following documents: (1) the Performance Bond; (2) the Payment Bond; and (3) the required insurance certificates and endorsements. Once City notifies the Bidder of the award, the Bidder will have ten (10) consecutive calendar days from the date of this notification to execute the Contract and supply City with all of the required documents and certifications. The City will issue a Notice to Proceed on or after the pre-construction meeting.

20. FILING OF BID PROTESTS

Bidders may file a "protest" of a Bid with City's Public Works Director / City Engineer. In order for a Bidder's protest to be considered valid, the protest must:

- A. Be filed in writing no later than 5:00 p.m. on the third (3rd) business day after the bid opening date;
- B. Clearly identify the specific irregularity or accusation;
- C. Specify, in detail, the grounds of the protest and the facts supporting the protest; and
- D. Include all relevant, supporting documentation with the protest at time of filing.
- E. Include verification that the party filing the protest has concurrently transmitted a copy of the protest to the apparent low bidder.
- F. Be signed and submitted under penalty of perjury under the laws of the State of California.

If the protest does not comply with each of these requirements, it may be rejected without further review.

If the protest is valid, the City will review the basis of the protest and relevant information prior to formal award of the bid. The City will not be required to hold an administrative hearing to consider a timely protest, but may do so at its sole option, or if otherwise legally required. The City has the sole authority to issue a final determination on all bid protests.

The procedure and time limits set forth in this section are mandatory and are the sole and exclusive remedy in the event of a bid protest. Failure to comply with these procedures shall constitute a failure to exhaust administrative remedies and a waiver of any right to further pursue the bid protest, including filing of a challenge of the award pursuant to the California Public Contract Code, filing of a claim pursuant to the California Government Code, or filing of any other legal proceedings.

SECTION 00200
INSTRUCTIONS TO BIDDERS

Nothing in this section shall be construed as a waiver of the City's right to reject any and all bids, to award any or all individual part/item of the bid, and to waive any informalities, irregularities or technical defects in such bids.

21. WORKERS COMPENSATION

Each bidder shall submit the Contractor's Certificate Regarding Workers' Compensation form.

22. SUBSTITUTION OF SECURITY

The Contract Documents call for monthly progress payments based upon the percentage of the work completed. The City will retain five percent (5%) of each progress payment as provided by the Contract Documents. At the request and expense of the successful Bidder, the City will substitute securities for the amount so retained in accordance with Public Contract Code Section 22300.

23. PREVAILING WAGES

City has obtained from the Director of the Department of Industrial Relations the general prevailing rate of per diem wages in the locality in which this work is to be performed for each craft or type of worker needed to execute the Contract. These rates are on file and available at the City of San Clemente Public Works Department Office at 910 Calle Negocio, San Clemente, CA 92673 or may be obtained online at <http://www.dir.ca.gov/dlsr>. Bidders are advised that a copy of these rates must be posted by the successful Bidder at the job site(s).

24. DEBARMENT OF CONTRACTORS AND SUBCONTRACTORS

In accordance with the provisions of the Labor Code, contractors or subcontractors may not perform work on a public works project with a subcontractor who is ineligible to perform work on a public project pursuant to Section 1777.1 or Section 1777.7 of the Labor Code. Any contract on a public works project entered into between a contractor and a debarred subcontractor is void as a matter of law. A debarred subcontractor may not receive any public money for performing work as a subcontractor on a public works contract. Any public money that is paid to a debarred subcontractor by the Contractor for the Project shall be returned to City. The Contractor shall be responsible for the payment of wages to workers of a debarred subcontractor who has been allowed to work on the Project.

25. IRAN CONTRACTING ACT CERTIFICATION

For bids of one million dollars (\$1,000,000) or more, each bidder shall submit the certification required by the Iran Contracting Act of 2010, Public Contract Code section 2200 et seq. as provided with the Bid Documents.

26. PUBLIC WORKS CONTRACTOR REGISTRATION CERTIFICATION

Pursuant to Labor Code sections 1725.5 and 1771.1, all contractors and subcontractors that wish to bid on, be listed in a bid proposal, or enter into a contract to perform public work must be registered with the Department of Industrial Relations. No bid will be accepted nor any contract

SECTION 00200
INSTRUCTIONS TO BIDDERS

entered into without proof of the contractor's and subcontractors' current registration with the Department of Industrial Relations to perform public work. If awarded a Contract, the Bidder and its subcontractors, of any tier, shall maintain active registration with the Department of Industrial Relations for the duration of the Project. To this end, Bidder shall sign and submit with its Bid the Public Works Contractor Registration Certification on the form provided, attesting to the facts contained therein. Failure to submit this form may render the Bid non-responsive. In addition, each Bidder shall provide the registration number for each listed subcontractor in the space provided in the Designation of Subcontractors Form.

27. PERFORMANCE BOND AND PAYMENT BOND REQUIREMENTS

Within the time specified in the Contract Documents, the Bidder to whom a Contract is awarded shall deliver to City four identical counterparts of the Performance Bond and Payment Bond in the form supplied by City and included in the Contract Documents. Failure to do so may, in the sole discretion of City, result in the forfeiture of the Bid Guarantee. The surety supplying the bond must be an admitted surety insurer, as defined in Code of Civil Procedure Section 995.120, authorized to do business as such in the State of California and satisfactory to City. The Performance Bond and the Payment Bond shall be for one hundred percent (100%) of the Total Bid Price.

28. REQUEST FOR SUBSTITUTIONS

The successful bidder shall comply with the substitution request procedures set forth in the Bid and Contract Documents. Any deadlines for substitution requests that occur prior to the bid opening date are set forth in the Special Conditions.

29. SALES AND OTHER APPLICABLE TAXES, PERMITS, LICENSES AND FEES

Contractor and its subcontractors performing work under this Contract will be required to pay California sales tax and other applicable taxes, and to pay for permits, licenses and fees required by the agencies with authority in the jurisdiction in which the work will be located, unless otherwise expressly provided by the Contract Documents.

30. EXECUTION OF CONTRACT

As required herein the Bidder to whom an award is made shall execute the Contract in the amount determined by the Contract Documents. City may require appropriate evidence that the persons executing the Contract are duly empowered to do so.

END OF INSTRUCTIONS TO BIDDERS

**SECTION 00400
BID FORM**

NAME OF BIDDER: _____

The undersigned, hereby declare that we have carefully examined the location of the proposed Work, and have read and examined the Contract Documents, including all plans, specifications, and all addenda, if any, for the following Project:

PARK MONUMENT SIGN REPLACEMENT PROGRAM, PROJECT No. 29103 – August 2023

We hereby propose to furnish all labor, materials, equipment, tools, transportation, and services, and to discharge all duties and obligations necessary and required to perform and complete the Project for the following TOTAL BID PRICE:

BASE BID SCHEDULE

SCHEDULE FOR MARBLEHEAD PARK AND MAX BERG PLAZA PARK MONUMENT SIGNS

Bid Item No.	Bid Item Description	Unit of Measure	Est. Qty	Unit Price	Total Item Cost
1	Mobilization	LS	1		
2	Existing concrete pad Demolition, Removal and Hauling	LS	1		
3	Excavation	CY	11		
4	Backfill	CY	4.8		
5	Masonry	SF	92		
6	Concrete	CY	4.0		
7	Reinforcing Steel	LB	800.0		
8	Stucco	SF	200		
9	Lettering	LS	1		
10	Brick Veneer	LS	1		

In case of discrepancy between the unit price and the item cost set forth for a unit basis item, the unit price shall prevail and, shall be utilized as the basis for determining the lowest responsive, responsible bidder. However, if the amount set forth as a unit price is ambiguous, unintelligible

SECTION 00400
BID FORM

or uncertain for any cause, or is omitted, or is the same amount as the entry in the "Item Cost" column, then the amount set forth in the "Item Cost" column for the item shall prevail and shall be divided by the estimated quantity for the item and the price thus obtained shall be the unit price. If any of the above discrepancies exist, the City may recalculate the bid price on the basis of the unit price and the bidder agrees to be bound by such recalculation.

It is understood that the quantities shown for the unit price items are approximate only and subject to increase or decrease, being stated only for the purpose of comparing bids and fixing the amount of surety bonds, and that should the quantity of work on the unit price basis be increased, the undersigned Bidder will perform the additional work at the unit price set out herein, and that should the quantity be decreased, payment is to be made on the actual quantity installed at such unit price, and the undersigned Bidder will make no claims for anticipated profits or additional compensation for any increase or decrease in the quantity. It is further understood that actual quantities on the unit price items will be determined upon completion of the work covered by the Contract.

Final payment shall be determined by the Engineer from measured quantities of work performed based upon the unit price.

TOTAL BID PRICE (BASED ON BASE BID SCHEDULE):

\$ _____

Total Base Bid Price in Numbers

Total Base Bid Price in Written Form

In case of discrepancy between the written price and the numerical price, the written price shall prevail. In case of a discrepancy between the electronic bid form in the City's Planet Bids system (if used) and this completed bid form, the signed hardcopy bid form (or scanned signed form uploaded to the City's Planet Bids system, shall prevail.

The undersigned agrees that this Bid Form constitutes a firm offer to City which cannot be withdrawn for the number of calendar days indicated in the Notice Inviting Bids from the bid opening, or until a Contract for the Work is fully executed by City and a third party, whichever is earlier.

The Contract duration shall commence on the date stated in City's Notice to Proceed, and shall be completed by the Contractor in the time specified in the Contract Documents. In no case shall the Contractor commence construction prior to the date stated in City's Notice to Proceed.

Bidder certifies that it is licensed in accordance with the law providing for the registration of Contractors, License No. _____, Expiration Date _____, class of license _____. If the bidder is a joint venture, each member of the joint venture must include the above information.

The undersigned acknowledges receipt, understanding and full consideration of the following addenda to the Contract Documents.

SECTION 00400
BID FORM

Addenda No. _____

Addenda No. _____

Addenda No. _____

Bidder has attached the following:

1. The completed Contractor's Certificate Regarding Workers' Compensation form.
2. The required bid security in the amount of not less than 10% of the Total Bid Price.
3. The fully executed Non-collusion Declaration form.
4. The completed Contractor Information and Experience form.
5. The completed List of Subcontractors form.
6. The completed Iran Contracting Act Certification form (for bids of \$1,000,000 or more).
7. The completed Public Works Contractor Registration Certification form.

I hereby certify under penalty of perjury under the laws of the State of California, that all of the information submitted in connection with this Bid and all of the representations made herein, including Contractor's license number and expiration date, are true and correct. I further certify that the signatory below is authorized to submit this Bid and bind the Bidder to the terms of these Contract Documents.

Name of Bidder _____

Signature _____

Name _____

Title _____

Dated _____

END OF BID FORM

**SECTION 00405
WORKER'S COMPENSATION INSURANCE CERTIFICATION**

WORKERS' COMPENSATION DECLARATION

I hereby affirm under penalty of perjury one of the following declarations:

(ONE OF THE BOXES BELOW MUST BE CHECKED)

I have and will maintain a certificate of consent from the California Labor Commission to self-insure for workers' compensation, as provided for by Section 3700 of the Labor Code, for the performance of the work to be performed under this contract.

I have and will maintain workers' compensation insurance, as required by Section 3700 of the Labor Code, for the performance of the work to be performed under this contract. My workers' compensation insurance carrier and policy number are:

Carrier _____

Policy Number _____

I certify that, in the performance of the work under this Agreement, I shall not employ any person in any manner so as to become subject to the workers' compensation laws of California, and I hereby agree to indemnify, defend, and hold harmless the City of San Clemente and all of its officials, employees, and agents from and against any and all claims, liabilities, and losses relating to personal injury or death, economic losses, and property damage arising out of my failure to provide such worker's compensation insurance. I further agree that, if I should become subject to the workers' compensation provisions of Section 3700 of the Labor Code, I shall forthwith comply with those provisions.

WARNING: FAILURE TO SECURE WORKERS' COMPENSATION COVERAGE IS UNLAWFUL, AND SHALL SUBJECT AN EMPLOYER TO CRIMINAL PENALTIES AND CIVIL FINES UP TO ONE HUNDRED THOUSAND DOLLARS (\$100,000), IN ADDITION TO THE COST OF COMPENSATION, DAMAGES AS PROVIDED FOR IN SECTION 3706 OF THE LABOR CODE, INTEREST, AND ATTORNEY'S FEES.

SECTION 00405
WORKER'S COMPENSATION INSURANCE CERTIFICATION

Dated: _____, 20____

Consultant

By: _____

Title

Address

**SECTION 00410
BID BOND**

The makers of this bond are _____, as Principal, and _____, as Surety and are held and firmly bound unto the City of San Clemente, hereinafter called City, in the penal sum of TEN PERCENT (10%) OF THE TOTAL BID PRICE of the Principal submitted to City for the work described below, for the payment of which sum in lawful money of the United States, well and truly to be made, we bind ourselves, our heirs, executors, administrators, successors and assigns, jointly and severally, firmly by these presents.

THE CONDITION OF THIS OBLIGATION IS SUCH that whereas the Principal has submitted the accompanying bid dated _____, 20__ for the PARK MONUMENT SIGN REPLACEMENT PROGRAM, PROJECT No. 29103.

If the Principal does not withdraw its bid within the time specified in the Contract Documents; and if the Principal is awarded the Contract and provides all documents to City as required by the Contract Documents; then this obligation shall be null and void. Otherwise, this bond will remain in full force and effect.

Surety, for value received, hereby stipulates and agrees that no change, extension of time, alteration or addition to the terms of the Contract Documents shall in affect its obligation under this bond, and Surety does hereby waive notice of any such changes.

In the event a lawsuit is brought upon this bond by City and judgment is recovered, the Surety shall pay all litigation expenses incurred by City in such suit, including reasonable attorneys' fees, court costs, expert witness fees and expenses.

IN WITNESS WHEREOF, the above-bound parties have executed this instrument under their several seals this _____ day of _____, 20__, the name and corporate seal of each corporation.

(Corporate Seal)_____

Contractor/ Principal

By

Title

(Corporate Seal)_____

Surety

By

Attorney-in-Fact

(Attach Attorney-in-Fact Certificate) Title _____

Notary Acknowledgment

A notary public or other officer completing this certificate verifies only the identity of the individual who signed the document to which this certificate is attached, and not the truthfulness, accuracy, or validity of that document.

STATE OF CALIFORNIA
COUNTY OF _____

On _____, 20____, before me, _____, Notary Public, personally appeared _____, who proved to me on the basis of satisfactory

evidence to be the person(s) whose name(s) is/are subscribed to the within instrument and acknowledged to me that he/she/they executed the same in his/her/their authorized capacity(ies), and that by his/her/their signature(s) on the instrument the person(s), or the entity upon behalf of which the person(s) acted, executed the instrument.

I certify under PENALTY OF PERJURY under the laws of the State of California that the foregoing paragraph is true and correct.

WITNESS my hand and official seal.

Signature of Notary Public

OPTIONAL

Though the information below is not required by law, it may prove valuable to persons relying on the document and could prevent fraudulent removal and reattachment of this form to another document.

CAPACITY CLAIMED BY SIGNER

DESCRIPTION OF ATTACHED DOCUMENT

- Individual
- Corporate Officer

- _____ Title(s)
- Partner(s)
 - Limited
 - General
 - Attorney-In-Fact
 - Trustee(s)
 - Guardian/Conservator
 - Other:
- Signer is representing:
Name Of Person(s) Or Entity(ies)

_____ Title or Type of Document

_____ Number of Pages

_____ Date of Document

_____ Signer(s) Other Than Named Above

**SECTION 00440
LIST OF SUBCONTRACTORS FORM**

In compliance with the Subletting and Subcontracting Fair Practices Act of the Public Contract Code of the State of California, each bidder shall set forth below: (a) the name and the location of the place of business, (b) the California contractor license number and DIR registration number, and (c) the portion of the work which will be done by each subcontractor who will perform work or labor or render service to the Contractor in or about the construction of the work in an amount in excess of one-half of one percent (1/2%) of the Contractor's Total Bid Price. Notwithstanding the foregoing, if the work involves streets and highways, then the Contractor shall list each subcontractor who will perform work or labor or render service to Contractor in or about the work in an amount in excess of one-half of one percent (1/2%) of the Contractor's Total Bid Price or \$10,000, whichever is greater. No additional time shall be granted to provide the below requested information.

If no subcontractor is specified, for a portion of the work, or if more than one subcontractor is specified for the same portion of Work, then the Contractor shall be deemed to have agreed that it is fully qualified to perform that Work, and that it shall perform that portion itself. **The Prime Contractor is required to complete at least over 50% of the contract value with its own forces.**

Work to be done by Subcontractor	Subcontractor	Location of Business	CSLB Contractor License No.	DIR Registration Number	% of the Work

SECTION 00440
LIST OF SUBCONTRACTORS FORM

Work to be done by Subcontractor	Subcontractor	Location of Business	CSLB Contractor License No.	DIR Registration Number	% of the Work

SECTION 00440
LIST OF SUBCONTRACTORS FORM

Work to be done by Subcontractor	Subcontractor	Location of Business	CSLB Contractor License No.	DIR Registration Number	% of the Work

In addition to submitting this Designation of Subcontractor form with its bid submission, each bidder shall, within 24 hours of the bid submission deadline, provide the City with a list of bid items that correspond to the portion of work listed for each designated subcontractor. Failure to provide this information within the time prescribed may be cause for the City to deem the Bid non-responsive and the City may reject the Bid.

Name of Bidder _____
 Signature _____
 Name _____
 Title _____
 Dated _____

END OF LIST OF SUBCONTRACTORS FORM

**SECTION 00430
CONTRACTOR INFORMATION AND EXPERIENCE FORM**

A. INFORMATION ABOUT BIDDER

****Failure to complete all information may render your bid nonresponsive - indicate not applicable ("N/A") where appropriate.****

NOTE: Where Bidder is a joint venture, pages shall be duplicated and information provided for all parties to the joint venture.

1.0 Name of Bidder: _____

2.0 Type, if Entity: _____

3.0 Bidder Address: _____

Facsimile Number _____ Telephone Number _____

Email Address _____

Website Address _____

4.0 How many years has Bidder's organization been in business as a Contractor?

5.0 How many years has Bidder's organization been in business under its present name? _____

5.1 Under what other or former names has Bidder's organization operated?: _____

6.0 If Bidder's organization is a corporation, answer the following:

6.1 Date of Incorporation: _____

6.2 State of Incorporation: _____

6.3 President's/CEO Name: _____

6.4 Vice President's Name(s): _____

6.5 Secretary's Name: _____

6.6 Treasurer's Name: _____

7.0 If an individual or a partnership, answer the following:

SECTION 00430
CONTRACTOR INFORMATION AND EXPERIENCE FORM

7.1 Date of Organization: _____

7.2 Name and address of all partners (state whether general or limited partnership):

8.0 If other than a corporation or partnership, describe organization and name principals:

9.0 List other states in which Bidder's organization is legally qualified to do business.

10.0 What type of work does the Bidder normally perform with its own forces?

11.0 Has Bidder ever failed to complete any work awarded to it? If so, note when, where, and why:

12.0 Has the Bidder ever been in default, debarred or suspended in any way? If so, note when and why:

13.0 Within the last five years, has any officer or partner of Bidder's organization ever been an officer or partner of another organization when it failed to complete a contract? If so, attach a separate sheet of explanation:

14.0 List Trade References (Materials Suppliers, Vendors, Union Representatives, etc.):

SECTION 00430
CONTRACTOR INFORMATION AND EXPERIENCE FORM

15.0 List Bank References (Bank and Branch Address):

16.0 Name of Bonding Company and Name and Address, email address and phone number of Agent:

SECTION 00430
CONTRACTOR INFORMATION AND EXPERIENCE FORM

Additional Bidder's Statements:

If the Bidder feels that there is additional information which has not been included in the questionnaire above, and which would contribute to the qualification review, it may add that information in a statement here or on an attached sheet, appropriately marked:

E. VERIFICATION AND EXECUTION

These Bid Forms shall be executed only by a duly authorized official of the Bidder:

I declare under penalty of perjury under the laws of the State of California that the foregoing information is true and correct:

Name of Bidder _____

Signature _____

Name _____

Title _____

Dated _____

END OF CONTRACTOR INFORMATION AND EXPERIENCE FORM

**SECTION 00420
NON-COLLUSION DECLARATION**

The undersigned declares:

I am the _____ of _____, the party making the foregoing bid.

The bid is not made in the interest of, or on behalf of, any undisclosed person, partnership, company, association, organization, or corporation. The bid is genuine and not collusive or sham. The bidder has not directly or indirectly induced or solicited any other bidder to put in a false or sham bid. The bidder has not directly or indirectly colluded, conspired, connived, or agreed with any bidder or anyone else to put in a sham bid, or to refrain from bidding. The bidder has not in any manner, directly or indirectly, sought by agreement, communication, or conference with anyone to fix the bid price of the bidder or any other bidder, or to fix any overhead, profit, or cost element of the bid price, or of that of any other bidder. All statements contained in the bid are true. The bidder has not, directly or indirectly, submitted his or her bid price or any breakdown thereof, or the contents thereof, or divulged information or data relative thereto, to any corporation, partnership, company association, organization, bid depository, or to any member or agent thereof to effectuate a collusive or sham bid, and has not paid, and will not pay, any person or entity for such purpose.

Any person executing this declaration on behalf of a bidder that is a corporation, partnership, joint venture, limited liability company, limited liability partnership, or any other entity, hereby represents that he or she has full power to execute, and does execute, this declaration on behalf of the bidder.

I declare under penalty of perjury under the laws of the State of California that the foregoing is true and correct and that this declaration is executed on _____[date], at _____[city], _____[state].

Name of Bidder_____

Signature_____

Name_____

Title_____

Dated_____

END OF NON-COLLUSION DECLARATION

**SECTION 00450
IRAN CONTRACTING ACT CERTIFICATION**

MUST BE SUBMITTED WITH BID PROPOSAL IF BID AMOUNT IS \$1,000,000 OR MORE

(Public Contract Code Section 2200 et seq.)

As required by California Public Contract Code Section 2204, the Contractor certifies subject to penalty for perjury that the option checked below relating to the Contractor's status in regard to the Iran Contracting Act of 2010 (Public Contract Code Section 2200 et seq.) is true and correct:

The Contractor is not:

(i) identified on the current list of persons and entities engaging in investment activities in Iran prepared by the California Department of General Services in accordance with subdivision (b) of Public Contract Code Section 2203; or

(ii) a financial institution that extends, for 45 days or more, credit in the amount of \$20,000,000 or more to any other person or entity identified on the current list of persons and entities engaging in investment activities in Iran prepared by the California Department of General Services in accordance with subdivision (b) of Public Contract Code Section 2203, if that person or entity uses or will use the credit to provide goods or services in the energy sector in Iran.

The City has exempted the Contractor from the requirements of the Iran Contracting Act of 2010 after making a public finding that, absent the exemption, the City will be unable to obtain the goods and/or services to be provided pursuant to the Contract. Documentation demonstrating the City's exemption approval is attached.

Signed: _____

Titled: _____

Firm: _____

Date: _____

Note: In accordance with Public Contract Code Section 2205, false certification of this form shall be reported to the California Attorney General and may result in civil penalties equal to the greater of \$250,000 or twice the Contract amount, termination of the Contract and/or ineligibility to bid on contracts for three years.

END OF IRAN CONTRACTING ACT CERTIFICATION

**SECTION 00460
PUBLIC WORKS CONTRACTOR REGISTRATION CERTIFICATION**

Pursuant to Labor Code sections 1725.5 and 1771.1, all contractors and subcontractors that wish to bid on, be listed in a bid proposal, or enter into a contract to perform public work must be registered with the Department of Industrial Relations. See <http://www.dir.ca.gov/Public-Works/PublicWorks.html> for additional information.

No bid will be accepted nor any contract entered into without proof of the contractor's and subcontractors' current registration with the Department of Industrial Relations to perform public work.

Bidder hereby certifies that it is aware of the registration requirements set forth in Labor Code sections 1725.5 and 1771.1 and is currently registered as a contractor with the Department of Industrial Relations.

Name of Bidder: _____

DIR Registration Number: _____

Bidder further acknowledges:

1. Bidder shall maintain a current DIR registration for the duration of the project.
2. Bidder shall include the requirements of Labor Code sections 1725.5 and 1771.1 in its contract with subcontractors and ensure that all subcontractors are registered at the time of bid opening and maintain registration status for the duration of the project.
3. Failure to submit this form or comply with any of the above requirements may result in a finding that the bid is non-responsive.

Name of Bidder _____

Signature _____

Name _____

Title _____

Dated _____

END OF PUBLIC WORKS CONTRACTOR REGISTRATION CERTIFICATION

**SECTION 00610
PERFORMANCE BOND**

KNOW ALL PERSONS BY THESE PRESENTS:

THAT WHEREAS, the City of San Clemente (hereinafter referred to as "City") has awarded to _____, (hereinafter referred to as the "Contractor") an agreement for PARK MONUMENT SIGN REPLACEMENT PROGRAM, PROJECT NO. 29103 – August 2023 (hereinafter referred to as the "Project").

WHEREAS, the work to be performed by the Contractor is more particularly set forth in the Contract Documents for the Project dated _____, (hereinafter referred to as "Contract Documents"), the terms and conditions of which are expressly incorporated herein by reference; and

WHEREAS, the Contractor is required by said Contract Documents to perform the terms thereof and to furnish a bond for the faithful performance of said Contract Documents.

NOW, THEREFORE, we, _____, the undersigned Contractor and _____ as Surety, a corporation organized and duly authorized to transact business under the laws of the State of California, are held and firmly bound unto the City in the sum of _____ DOLLARS and _____ CENTS (\$ _____), said sum being not less than one hundred percent (100%) of the total amount of the Contract, for which amount well and truly to be made, we bind ourselves, our heirs, executors and administrators, successors and assigns, jointly and severally, firmly by these presents.

THE CONDITION OF THIS OBLIGATION IS SUCH, that, if the Contractor, his or its heirs, executors, administrators, successors or assigns, shall in all things stand to and abide by, and well and truly keep and perform the covenants, conditions and agreements in the Contract Documents and any alteration thereof made as therein provided, on its part, to be kept and performed at the time and in the manner therein specified, and in all respects according to their intent and meaning; and shall faithfully fulfill all obligations including, if provided as part of the Contract Documents, the one-year guarantee of all materials and workmanship; and shall indemnify and save harmless the City, its officers and agents, as stipulated in said Contract Documents, then this obligation shall become null and void; otherwise it shall be and remain in full force and effect.

As a condition precedent to the satisfactory completion of the Contract Documents, unless otherwise provided for in the Contract Documents, the guarantee obligation shall hold good for a period of one (1) year after the acceptance of the work by City, during which time if Contractor shall fail to make full, complete, and satisfactory repair and replacements and totally protect the City from loss or damage resulting from or caused by defective materials or faulty workmanship the above obligation in penal sum thereof shall remain in full force and effect. However, anything in this paragraph to the contrary notwithstanding, the obligations of Surety hereunder shall continue so long as any obligation of Contractor remains. Nothing herein shall limit the City's rights or the Contractor or Surety's obligations under the Contract Documents, law or equity, including, but not limited to, California Code of Civil Procedure section 337.15.

SECTION 00610
PERFORMANCE BOND

Whenever Contractor shall be, and is declared by the City to be, in default under the Contract Documents, the Surety shall remedy the default pursuant to the Contract Documents, or shall promptly, at the City's option:

- (1) Take over and complete the Project in accordance with all terms and conditions in the Contract Documents; or
- (2) Obtain a bid or bids for completing the Project in accordance with all terms and conditions in the Contract Documents and upon determination by Surety of the lowest responsive and responsible bidder, arrange for a contract between such bidder, the Surety and the City, and make available as work progresses sufficient funds to pay the cost of completion of the Project, less the balance of the contract price, including other costs and damages for which Surety may be liable. The term "balance of the contract price" as used in this paragraph shall mean the total amount payable to Contractor by the City under the Contract Documents and any modification thereto, less any amount previously paid by the City to the Contractor and any other set offs pursuant to the Contract Documents.
- (3) Permit the City to complete the Project in any manner consistent with California law and make available as work progresses sufficient funds to pay the cost of completion of the Project, less the balance of the contract price, including other costs and damages for which Surety may be liable. The term "balance of the contract price" as used in this paragraph shall mean the total amount payable to Contractor by the City under the Contract Documents and any modification thereto, less any amount previously paid by the City to the Contractor and any other set offs pursuant to the Contract Documents.

Surety expressly agrees that the City may reject any contractor or subcontractor which may be proposed by Surety in fulfillment of its obligations in the event of default by the Contractor.

Surety shall not utilize Contractor in completing the Project nor shall Surety accept a bid from Contractor for completion of the Project if the City, when declaring the Contractor in default, notifies Surety of the City's objection to Contractor's further participation in the completion of the Project.

The Surety, for value received, hereby stipulates and agrees that no change, extension of time, alteration or addition to the terms of the Contract Documents or to the Project to be performed thereunder shall in any way affect its obligations on this bond, and it does hereby waive notice of any such change, extension of time, alteration or addition to the terms of the Contract Documents or to the Project and the provisions of Section 2819 and 2845 of the California Civil Code. Without limiting the foregoing, such changes, extensions of time and alterations or additions shall include, but are not limited to, changes or alterations to the Contract Documents (including, without limitation, an increase in the total dollar amount of the Contract Documents), extensions of time, or modifications of the time, terms, or conditions of payment to the Contractor.

IN WITNESS WHEREOF, we have hereunto set our hands and seals this _____ day of _____, 20__.

SECTION 00610
PERFORMANCE BOND

CONTRACTOR/PRINCIPAL
(Corporate Seal of Contractor/
Principal, if a Corporation)

Name of Contractor/Principal (Type or Print)

By: _____
Name (Signature)

Name (Type or Print)

Title (Type or Print)

SURETY
(Seal of Surety)

Name of Surety (Type or Print)

By: _____
Attorney-In-Fact

Signatures of those signing for the Contractor and Surety must be notarized and evidence of corporate authority attached.

The rate of premium on this bond is _____ per thousand. The total amount of premium charges, \$_____.

(The above must be filled in by corporate attorney.)

THIS IS A REQUIRED FORM

Any claims under this bond may be addressed to:

(Name and Address of Surety) _____

(Name and Address of Agent or Representative for service of process in California, if different from above) _____

(Telephone number of Surety and Agent or Representative for service of process in California) _____

SECTION 00610
PERFORMANCE BOND

Notary Acknowledgment

A notary public or other officer completing this certificate verifies only the identity of the individual who signed the document to which this certificate is attached, and not the truthfulness, accuracy, or validity of that document.

STATE OF CALIFORNIA
COUNTY OF _____

On _____, 20____, before me, _____, Notary Public, personally appeared _____, who proved to me on the basis of satisfactory

evidence to be the person(s) whose name(s) is/are subscribed to the within instrument and acknowledged to me that he/she/they executed the same in his/her/their authorized capacity(ies), and that by his/her/their signature(s) on the instrument the person(s), or the entity upon behalf of which the person(s) acted, executed the instrument.

I certify under PENALTY OF PERJURY under the laws of the State of California that the foregoing paragraph is true and correct.

WITNESS my hand and official seal.

Signature of Notary Public

OPTIONAL

Though the information below is not required by law, it may prove valuable to persons relying on the document and could prevent fraudulent removal and reattachment of this form to another document.

CAPACITY CLAIMED BY SIGNER

DESCRIPTION OF ATTACHED DOCUMENT

- Individual
- Corporate Officer

_____ Title(s)

_____ Title or Type of Document

- Partner(s) Limited
- General

_____ Number of Pages

- Attorney-In-Fact
- Trustee(s)
- Guardian/Conservator
- Other:

_____ Date of Document

Signer is representing:
Name Of Person(s) Or Entity(ies)

_____ Signer(s) Other Than Named Above

NOTE: A copy of the Power-of-Attorney to local representatives of the bonding company must be attached hereto.

END OF PERFORMANCE BOND FORM

**SECTION 00620
PAYMENT BOND**

KNOW ALL MEN BY THESE PRESENTS That

WHEREAS, the City of San Clemente (hereinafter designated as the "City"), by action taken or a resolution passed _____, 20____ has awarded to _____ hereinafter designated as the "Principal," a contract for the work described as follows PARK MONUMENT SIGN REPLACEMENT PROGRAM, PROJECT NO. 29103 – August 2023 (the "Project"); and

WHEREAS, the work to be performed by the Principal is more particularly set forth in the Contract Documents for the Project dated _____, (hereinafter referred to as "Contract Documents"), the terms and conditions of which are expressly incorporated herein by reference; and

WHEREAS, said Principal is required to furnish a bond in connection with said Contract Documents; providing that if said Principal or any of its Subcontractors shall fail to pay for any materials, provisions, provender, equipment, or other supplies used in, upon, for or about the performance of the work contracted to be done, or for any work or labor done thereon of any kind, or for amounts due under the Unemployment Insurance Code or for any amounts required to be deducted, withheld, and paid over to the Employment Development Department from the wages of employees of said Principal and its Subcontractors with respect to such work or labor, the Surety on this bond will pay for the same to the extent hereinafter set forth.

NOW THEREFORE, we, the Principal and _____ as Surety, are held and firmly bound unto the City in the penal sum of _____ DOLLARS and _____ CENTS (\$_____) lawful money of the United States of America, for the payment of which sum well and truly to be made, we bind ourselves, our heirs, executors, administrators, successors and assigns, jointly and severally, firmly by these presents.

THE CONDITION OF THIS OBLIGATION IS SUCH that if said Principal, his or its subcontractors, heirs, executors, administrators, successors or assigns, shall fail to pay any of the persons named in Section 9100 of the Civil Code, fail to pay for any materials, provisions or other supplies, used in, upon, for or about the performance of the work contracted to be done, or for any work or labor thereon of any kind, or amounts due under the Unemployment Insurance Code with respect to work or labor performed under the Contract Documents, or for any amounts required to be deducted, withheld, and paid over to the Employment Development Department or Franchise Tax Board from the wages of employees of the contractor and his subcontractors pursuant to Section 18663 of the Revenue and Taxation Code, with respect to such work and labor the Surety or Sureties will pay for the same, in an amount not exceeding the sum herein above specified, and also, in case suit is brought upon this bond, all litigation expenses incurred by the City in such suit, including reasonable attorneys' fees, court costs, expert witness fees and investigation expenses.

This bond shall insure to the benefit of any of the persons named in Section 9100 of the Civil Code so as to give a right of action to such persons or their assigns in any suit brought upon this bond.

SECTION 00620
PAYMENT BOND

It is further stipulated and agreed that the Surety on this bond shall not be exonerated or released from the obligation of this bond by any change, extension of time for performance, addition, alteration or modification in, to, or of any contract (including the Contract Documents), plans, specifications, or agreement pertaining or relating to any scheme or work of improvement herein above described, or pertaining or relating to the furnishing of labor, materials, or equipment therefore, nor by any change or modification of any terms of payment or extension of the time for any payment pertaining or relating to any scheme or work of improvement herein above described, nor by any rescission or attempted rescission or attempted rescission of the Contract Documents, agreement or bond, nor by any conditions precedent or subsequent in the bond attempting to limit the right of recovery of claimants otherwise entitled to recover under any such contract or agreement or under the bond, nor by any fraud practiced by any person other than the claimant seeking to recover on the bond and that this bond be construed most strongly against the Surety and in favor of all persons for whose benefit such bond is given, and under no circumstances shall Surety be released from liability to those for whose benefit such bond has been given, by reason of any breach of contract between the owner or City and original contractor or on the part of any obligee named in such bond, but the sole conditions of recovery shall be that claimant is a person described in Section 9100 of the Civil Code, and has not been paid the full amount of his claim and that Surety does hereby waive notice of any such change, extension of time, addition, alteration or modification herein mentioned.

Notwithstanding any other provision of this bond, it is expressly understood, acknowledged and agreed that it shall provide all of the protections required by California Civil Code Sections 9550 through 9566, including the specific coverage protections required by Section 9554.

REMAINDER OF PAGE LEFT INTENTIONALLY BLANK

SIGNATURES ON FOLLOWING PAGE

SECTION 00620
PAYMENT BOND

IN WITNESS WHEREOF, two (2) identical counterparts of this instrument, each of which shall for all purposes be deemed an original thereof, have been duly executed by the Principal and Surety above named, on the ____ day of _____ 20____ the name and corporate seal of each corporate party being hereto affixed and these presents duly signed by its undersigned representative pursuant to authority of its governing body.

CONTRACTOR/PRINCIPAL
(Corporate Seal of Contractor/
Principal, if a Corporation)

Name of Contractor/Principal (Type or Print)

By: _____
Name (Signature)

Name (Type or Print)

Title (Type or Print)

SURETY
(Seal of Surety)

Name of Surety (Type or Print)

By: _____
Attorney-In-Fact

Notary Acknowledgment

A notary public or other officer completing this certificate verifies only the identity of the individual who signed the document to which this certificate is attached, and not the truthfulness, accuracy, or validity of that document.

STATE OF CALIFORNIA
COUNTY OF _____

On _____, 20____, before me, _____, Notary Public, personally appeared _____, who proved to me on the basis of satisfactory

evidence to be the person(s) whose name(s) is/are subscribed to the within instrument and acknowledged to me that he/she/they executed the same in his/her/their authorized capacity(ies), and that by his/her/their signature(s) on the instrument the person(s), or the entity upon behalf of which the person(s) acted, executed the instrument.

I certify under PENALTY OF PERJURY under the laws of the State of California that the foregoing paragraph is true and correct.

WITNESS my hand and official seal.

Signature of Notary Public

OPTIONAL

Though the information below is not required by law, it may prove valuable to persons relying on the document and could prevent fraudulent removal and reattachment of this form to another document.

CAPACITY CLAIMED BY SIGNER

DESCRIPTION OF ATTACHED DOCUMENT

- Individual
- Corporate Officer

_____ Title(s)

_____ Title or Type of Document

- Partner(s) Limited
- General

_____ Number of Pages

- Attorney-In-Fact
- Trustee(s)
- Guardian/Conservator
- Other:

_____ Date of Document

Signer is representing:
Name Of Person(s) Or Entity(ies)

_____ Signer(s) Other Than Named Above

NOTE: A copy of the Power-of-Attorney to local representatives of the bonding company must be attached hereto.

END OF PAYMENT BOND FORM

**SECTION 00700
GENERAL CONDITIONS**

ARTICLE 1. DEFINITIONS

- a. Acceptable, Acceptance or words of similar import shall be understood to be the acceptance of the Engineer and/or City.
- b. Act of God is an earthquake in excess of a magnitude of 3.5 on the Richter scale and tidal waves.
- c. Approval means written authorization by Engineer and/or City.
- d. Contract Documents includes all documents as stated in the Contract.
- e. City and Contractor are those stated in the Contract. The terms City and Owner may be used interchangeably.
- f. Day shall mean working day unless otherwise specifically designated.
- g. Engineer shall mean the City Manager, or his or her designee, of the City, acting either directly or through properly authorized agents, such as agents acting within the scope of the particular duties entrusted to them. Also sometimes referred to as "City's Representative" or "Representative" in the Contract Documents.
- h. Equal, Equivalent, Satisfactory, Directed, Designated, Selected, As Required and similar words shall mean the written approval, selection, satisfaction, direction, or similar action of the Engineer and/or City.
- i. Indicated, Shown, Detailed, Noted, Scheduled or words of similar meaning shall mean that reference is made to the drawings, unless otherwise noted. It shall be understood that the direction, designation, selection, or similar import of the Engineer and/or City is intended, unless stated otherwise.
- j. Install means the complete installation of any item, equipment or material.
- k. Material shall include machinery, equipment, manufactured articles, or construction such as form work, fasteners, etc., and any other classes of material to be furnished in connection with the Contract. All materials shall be new unless specified otherwise.
- l. Perform shall mean that the Contractor, at Contractor's expense, shall take all actions necessary to complete The Work, including furnishing of necessary labor, tools, and equipment, and providing and installing Materials that are indicated, specified, or required to complete such performance.
- m. Project is The Work planned by City as provided in the Contract Documents.

SECTION 00700
GENERAL CONDITIONS

- n. Provide shall include provide, complete in place, that is furnish, install, test and make ready for use.
- o. Recyclable Waste Materials shall mean materials removed from the Project site which are required to be diverted to a recycling center rather than an area landfill. Recyclable Waste Materials include but are not necessarily limited to asphalt, concrete, brick, concrete block, and rock.
- p. Specifications means that portion of the Contract Documents consisting of the written requirements for materials, equipment, construction systems, standards and workmanship for the work. Except for Sections 1-8 of the Standard Specifications for Public Works Construction (“Greenbook”), Latest Edition, which are specifically excluded from incorporation into these Contract Documents, the Work shall be done in accordance with the Greenbook, including all current supplements, addenda, and revisions thereof, as well as other applicable standards which may be referenced in the Contract Documents. In the case of conflict between the Greenbook and the Contract Documents, the Contract Documents shall prevail.
- q. The Work means the entire improvement planned by City pursuant to the Contract Documents.
- r. Work means labor, equipment and materials incorporated in, or to be incorporated in the construction covered by the Contract Documents.

ARTICLE 2. CONTRACT DOCUMENTS

- a. Intent of Contract Documents. The intent of the Contract Documents is to prescribe a complete work of improvement which Contractor shall perform or cause to be performed in a manner acceptable to the Engineer and in full compliance with all codes and the terms of this Agreement. Contractor shall complete a functional or operable improvement or facility, even though the Contract Documents may not specifically call out all items of work required for the Contractor to complete its tasks, incidental appurtenances, materials, and the like. If any omissions are made of information necessary to carry out the full intent and meaning of the Contract Documents, Contractor shall immediately seek approval of the Engineer for furnishing detailed instructions. Further, prior to commencing performance of any work hereunder, Contractor shall cooperate with and assist the City to identify and make any refinements to the description and scope of the work that may be necessary to achieve City’s goals hereunder. In the event of any doubt or question arising regarding the true meaning of any of the Contract Documents or any portion thereof, reference shall be made to the Engineer whose decision thereon shall be final.
- b. Interpretations. The Contract Documents are intended to be fully cooperative and to be complementary. If Contractor observes that any documents are in conflict, the Contractor shall promptly notify the Engineer in writing. In case of conflicts between the Contract Documents, the order of precedence shall be as follows:
 - 1) Change Orders or Work Change Directives

SECTION 00700
GENERAL CONDITIONS

- 2) Addenda
- 3) Special Provisions (or Special Conditions)
- 4) Technical Specifications
- 5) Plans (Contract Drawings)
- 6) Contract
- 7) General Conditions
- 8) Instructions to Bidders
- 9) Notice Inviting Bids
- 10) Contractor's Bid Forms
- 11) Greenbook Standard Specifications (Sections 1-8 Excluded)
- 12) Standard Plans
- 13) Reference Documents

With reference to the Drawings, the order of precedence shall be as follows:

- 1) Figures govern over scaled dimensions
 - 2) Detail drawings govern over general drawings
 - 3) Addenda or Change Order drawings govern over Contract Drawings
 - 4) Contract Drawings govern over Standard Drawings
 - 5) Contract Drawings govern over Shop Drawings
- c. Conflicts in Contract Documents. Notwithstanding the orders of precedence established above, in the event of conflicts, the higher standard shall always apply.
- d. Organization of Contract Documents. Organization of the Contract Documents into divisions, sections, and articles, and arrangement of drawings shall not control the Contractor in dividing The Work among subcontractors or in establishing the extent of Work to be performed by any trade.

ARTICLE 3. CONTRACTS DOCUMENTS: COPIES & MAINTENANCE

Contractor will be furnished, free of charge, two (2) copies of the Contract Documents. Additional copies may be obtained at cost of reproduction.

Contractor shall maintain a clean, undamaged set of Contract Documents at the Project site.

ARTICLE 4. DETAIL DRAWINGS AND INSTRUCTIONS

- a. Examination of Contract Documents. Before commencing any portion of The Work, Contractor shall again carefully examine all applicable Contract Documents, the Project site and other information given to Contractor as to materials and methods of construction and other Project requirements. Contractor shall immediately notify the Engineer of any potential error, inconsistency, ambiguity, conflict or lack of detail or explanation. If Contractor performs, permits, or causes the performance of any Work which is in error, inconsistent or ambiguous, or not sufficiently detailed or explained, Contractor shall bear any and all resulting costs, including, without limitation, the cost of correction. In no case shall the Contractor or any subcontractor proceed with Work if uncertain as to the applicable requirements.
- b. Additional Instructions. After notification of any error, inconsistency, ambiguity, conflict or lack of detail or explanation, the Engineer will provide any required additional instructions, by means of drawings or other written direction, necessary for proper execution of Work.
- c. Quality of Parts, Construction and Finish. All parts of The Work shall be of the best quality of their respective kinds and the Contractor must use all diligence to inform itself fully as to the required construction and finish. In no case shall Contractor proceed with The Work without obtaining first from the Engineer such Approval may be necessary for the proper performance of Work.
- d. Contractor's Variation from Contract Document Requirements. If it is found that the Contractor has varied from the requirements of the Contract Documents including the requirement to comply with all applicable laws, ordinances, rules and regulations, the Engineer may at any time, before or after completion of the Work, order the improper Work removed, remade or replaced by the Contractor at the Contractor's expense.

ARTICLE 5. EXISTENCE OF UTILITIES AT THE WORK SITE

- a. City has endeavored to determine the existence of utilities at the Project site from the records of the owners of known utilities in the vicinity of the Project. The positions of these utilities as derived from such records are shown on the Plans.
- b. Only limited excavations were made to verify the locations shown for underground utilities. No guarantee is made or implied that the information is complete or accurate. It shall be the Contractor's responsibility alone to determine the exact location of underground utilities or substructures of every nature and to protect them from damage.
- c. The service connections to these utilities are not shown on the plans. It shall be the responsibility of the Contractor to determine the exact location of all service connections and, if necessary, Contractor shall arrange for the relocation of service connections. The Contractor shall make its own investigations, including exploratory excavations, to determine the locations and type of service connections, prior to commencing Work which could result in damage to such

SECTION 00700
GENERAL CONDITIONS

utilities. The Contractor shall immediately notify City in writing of any utility discovered in a different position than shown on the Plans or which is not shown on the Plans.

- d. All water meters, water valves, fire hydrants, electrical utility vaults, telephone vaults, gas utility valves, and other subsurface structures shall be relocated or adjusted to final grade by the Contractor. Locations of existing utilities shown on the Plans are approximate and may not be complete. The Contractor shall be responsible for coordinating its Work with all utility companies during the construction of The Work. The Contractor will not be entitled to damages or additional payment for delays attributable to utility relocations or alterations
- e. Notwithstanding the above, pursuant to Section 4215 of the Government Code, City has the responsibility to identify, with reasonable accuracy, main or trunkline facilities on the plans and specifications. In the event that main or trunkline utility facilities are not identified with reasonable accuracy in the plans and specifications made a part of the invitation for bids, City shall assume the responsibility for their timely removal, relocation, or protection.
- f. Contractor, except in an emergency, shall contact the appropriate regional notification center, Southern California Underground Service Alert at 1-800-227-2600 at least two working days prior to commencing any excavation if the excavation will be performed in an area which is known, or reasonably should be known, to contain subsurface installations other than the underground facilities owned or operated by City, and obtain an inquiry identification number from that notification center. No excavation shall be commenced or carried out by the Contractor unless such an inquiry identification number has been assigned to the Contractor or any subcontractor of the Contractor and City has been given the identification number by the Contractor.

ARTICLE 6. SCHEDULE

- a. Planned Schedule. Contractor shall prepare a proposed Project schedule and shall submit this for approval to the Engineer at the pre-construction meeting or as otherwise provided in the Special Provisions. The Engineer shall promptly provide written acceptance of the proposed schedule, or notify Contractor that the proposed schedule is not acceptable with accompanying explanation. In such case Contractor shall revise and re-submit an updated schedule within five (5) working days of the Engineer's notification. The receipt or Approval of any schedules by the Engineer or City shall not in any way relieve the Contractor of its obligations under the Contract Documents. The Contractor is fully responsible to determine and provide for any and all staffing and resources at levels which allow for good quality and timely completion of the Project. Contractor's failure to incorporate all elements of Work required for the performance of the Contract or any inaccuracy in the schedule shall not excuse the Contractor from performing all Work required for a completed Project within the specified Contract time period. If the required schedule is not received by the time the first payment under the Contract is due, Contractor shall not be paid until the schedule is received, reviewed and accepted by the Engineer.

SECTION 00700
GENERAL CONDITIONS

- b. Schedule Contents. The schedule shall allow enough time for inclement weather. The schedule shall specify the progression of activities from the date of the Notice to Proceed to the end of the Contract Time, indicate the beginning and completion dates of all phases of construction; the order in which the Contractor proposes to carry out the work, critical path for all critical, sequential time related activities; and “float time” for all “slack” or “gaps” in the non-critical activities. The schedule shall include appropriate time allowances and constraints for submittals, permits, inspections, performance and material testing, and work that may be required by others for the completion of the Contractor’s work. The schedule shall clearly identify all staffing and other resources which in the Contractor’s judgment are needed to complete the Project within the time specified for completion. The schedule(s) submitted shall be consistent in all respects with the completion time requirements and any order of work requirements set forth in the Contract Documents.

- c. Schedule Updates. Contractor shall continuously update its construction schedule, and shall provide to the Engineer full information in advance as to the Contractor’s plans for carrying out any part of the work. Contractor shall submit an updated and accurate construction schedule to the Engineer whenever requested to do so by Engineer and with each progress payment request. The Engineer may withhold progress payments or other amounts due under the Contract Documents if Contractor fails to submit an updated and accurate construction schedule.

ARTICLE 7. SUBSTITUTIONS

- a. Pursuant to Public Contract Code Section 3400(b) City may make a finding that is described in the invitation for bids that designates certain products, things, or services by specific brand or trade name.

- b. Unless specifically designated in the Contract Documents, whenever any material, process, or article is indicated or specified by grade, patent, or proprietary name or by name of manufacturer, such Specifications shall be deemed to be used for the purpose of facilitating the description of the material, process or article desired and shall be deemed to be followed by the words “or equal.” Contractor may, unless otherwise stated, offer for substitution any material, process or article which shall be substantially equal or better in every respect to that so indicated or specified in the Contract Documents. However, City may have adopted certain uniform standards for certain materials, processes and articles.

- c. Contractor shall submit requests, together with substantiating data, for substitution of any “or equal” material, process or article no later than thirty-five (35) days after award of the Contract. To facilitate the construction schedule and sequencing, some requests may need to be submitted before thirty-five (35) days after award of Contract. Provisions regarding submission of “or equal” requests shall not in any way authorize an extension of time for performance of this Contract. If a proposed “or equal” substitution request is rejected, Contractor shall be responsible for providing the specified material, process or article. The burden of proof as to the equality of any material, process or article shall rest with the Contractor. City has the complete and sole discretion to determine if a material,

SECTION 00700
GENERAL CONDITIONS

process or article is an “or equal” material, process or article that may be substituted.

- d. Data required to substantiate requests for substitutions of an “or equal” material, process or article data shall include a signed affidavit from the Contractor stating that, and describing how, the substituted “or equal” material, process or article is equivalent to that specified in every way except as listed on the affidavit. Substantiating data shall include any and all illustrations, specifications, and other relevant data including catalog information which describes the requested substituted “or equal” material, process or article, and substantiates that it is an “or equal” to the material, process or article. The substantiating data must also include information regarding the durability and lifecycle cost of the requested substituted “or equal” material, process or article. Failure to submit all the required substantiating data, including the signed affidavit, to City in a timely fashion will result in the rejection of the proposed substitution.
- e. The Contractor shall bear all of City’s costs associated with the review of substitution requests.
- f. The Contractor shall be responsible for all costs related to a substituted “or equal” material, process or article.
- g. Contractor is directed to the Special Conditions (if any) to review any findings made pursuant to Public Contract Code section 3400.

ARTICLE 8. SHOP DRAWINGS

- a. Contractor shall check and verify all field measurements and shall submit with such promptness as to provide adequate time for review and cause no delay in his own Work or in that of any other contractor, subcontractor, or worker on the Project, six (6) copies of all shop or setting drawings, calculations, schedules, and materials list, and all other provisions required by the Contract. Contractor shall sign all submittals affirming that submittals have been reviewed and approved by Contractor prior to submission to Engineer. Each signed submittal shall affirm that the submittal meets all the requirements of the Contract Documents except as specifically and clearly noted and listed on the cover sheet of the submittal.
- b. Contractor shall make any corrections required by the Engineer, and file with the Engineer six (6) corrected copies each, and furnish such other copies as may be needed for completion of the Work. Engineer’s approval of shop drawings shall not relieve Contractor from responsibility for deviations from the Contract Documents unless Contractor has, in writing, called Engineer’s attention to such deviations at time of submission and has secured the Engineer’s written Approval. Engineer’s Approval of shop drawings shall not relieve Contractor from responsibility for errors in shop drawings.

ARTICLE 9. SUBMITTALS

- a. Contractor shall furnish to the Engineer for approval, prior to purchasing or commencing any Work, a log of all samples, material lists and certifications, mix

SECTION 00700
GENERAL CONDITIONS

designs, schedules, and other submittals, as required in the specifications. The log shall indicate whether samples will be provided in accordance with other provisions of this Contract.

- b. Contractor will provide samples and submittals, together with catalogs and supporting data required by the Engineer, to the Engineer within a reasonable time period to provide for adequate review and avoid delays in the Work.
- c. These requirements shall not authorize any extension of time for performance of this Contract. Engineer will check and approve such samples, but only for conformance with design concept of work and for compliance with information given in the Contract Documents. Work shall be in accordance with approved samples and submittals.

ARTICLE 10. MATERIALS

- a. Except as otherwise specifically stated in the Contract Documents, Contractor shall provide and pay for all materials, labor, tools, equipment, water, lights, power, transportation, superintendence, temporary constructions of every nature, and all other services and facilities of every nature whatsoever necessary to execute and complete this Contract within specified time.
- b. Unless otherwise specified, all materials shall be new and the best of their respective kinds and grades as noted and/or specified, and workmanship shall be of good quality.
- c. Materials shall be furnished in ample quantities and at such times as to ensure uninterrupted progress of The Work and shall be stored properly and protected as required by the Contract Documents. Contractor shall be entirely responsible for damage or loss by weather or other causes to materials or Work.
- d. No materials, supplies, or equipment for Work under this Contract shall be purchased subject to any chattel mortgage or under a conditional sale or other agreement by which an interest therein or in any part thereof is retained by the seller or supplier. Contractor warrants good title to all material, supplies, and equipment installed or incorporated in the work and agrees upon completion of all work to deliver the Project, to City free from any claims, liens, or charges.
- e. Materials shall be stored on the Project site in such manner so as not to interfere with any operations of City or any independent contractor.

ARTICLE 11. CONTRACTOR'S SUPERVISION

Contractor shall continuously keep at the Project site, a competent and experienced full-time Project superintendent approved by City. Superintendent must be able to proficiently speak, read and write in English. Contractor shall continuously provide efficient supervision of the Project.

ARTICLE 12. WORKERS

- a. Contractor shall at all times enforce strict discipline and good order among its employees. Contractor shall not employ on the Project any unfit person or any one not skilled in the Work assigned to him or her.
- b. Any employee of the Contractor whom City determines is incompetent or unfit shall be removed from this Project.

ARTICLE 13. SUBCONTRACTORS

- a. Contractor agrees to bind every subcontractor to the terms of the Contract Documents as far as such terms are applicable to subcontractor's portion of The Work. All subcontracts entered into by Contractor relating to any of the Work under this Contract shall comply with and be limited to the extent required by Civil Code section 2872.05. Contractor shall be as fully responsible to City for the acts and omissions of its subcontractors and of persons either directly or indirectly employed by its subcontractors, as Contractor is for acts and omissions of persons directly employed by Contractor. Nothing contained in these Contract Documents shall create any contractual relationship between any subcontractor and City.
- b. City reserves the right to Approve all subcontractors. City's Approval of any subcontractor under this Contract shall not in any way relieve Contractor of its obligations in the Contract Documents.
- c. Prior to substituting any subcontractor listed in the Bid Forms, Contractor must comply with the requirements of the Subletting and Subcontracting Fair Practices Act pursuant to California Public Contract Code section 4100 et seq.

ARTICLE 14. PERMITS AND LICENSES

Permits and licenses necessary for prosecution of The Work shall be secured and paid for by Contractor, unless otherwise specified in the Contract Documents.

- a. Contractor shall obtain and pay for all other permits and licenses required for The Work, including excavation permit and for plumbing, mechanical and electrical work and for operations in or over public streets or right of way under jurisdiction of public agencies other than City.
- b. The Contractor shall arrange and pay for all off-site inspection of the Work related to permits and licenses, including certification, required by the specifications, drawings, or by governing authorities, except for such off-site inspections delineated as City's responsibility pursuant to the Contract Documents.
- c. Before Acceptance of the Project, the Contractor shall submit all licenses, permits, certificates of inspection and required approvals to City.

ARTICLE 15. UTILITY USAGE

- a. All temporary utilities, including but not limited to electricity, water, gas, and telephone, used on the Work shall be furnished and paid for by Contractor. Contractor shall provide necessary temporary distribution systems, including meters, if necessary, from distribution points to points on The Work where the utility is needed. Upon completion of The Work, Contractor shall remove all temporary distribution systems.
- b. Contractor shall provide necessary and adequate utilities and pay all costs for water, electricity, gas, oil, and sewer charges required for completion of the Project.
- c. All permanent meters Installed shall be listed in the Contractor's name until the Work is accepted.
- d. If the Contract is for construction in existing facilities, Contractor may, with prior written Approval of City, use City's existing utilities by compensating City for utilities used by Contractor.

ARTICLE 16. INSPECTION FEES FOR PERMANENT UTILITIES

All inspection fees and other municipal charges for permanent utilities including, but not limited to, sewer, electrical, phone, gas, water, and irrigation shall be paid for by City. Contractor shall be responsible for arranging the payment of such fees, but inspection fees and other municipal fees relating to permanent utilities shall be paid by City. Contractor may either request reimbursement from City for such fees, or shall be responsible for arranging and coordination with City for the payment of such fees.

ARTICLE 17. TRENCHES

- a. Trenches Five Feet or More in Depth. The Contractor shall submit to City, in advance of excavation, a detailed plan showing the design of shoring, bracing, sloping or other provisions to be made for worker protection from the hazard of caving ground during the excavation of any trench or trenches five feet or more in depth. If the plan varies from shoring system standards, the plan shall be prepared by a registered civil or structural engineer. The plan shall not be less effective than the shoring, bracing, sloping, or other provisions of the Construction Safety Orders, as defined in the California Code of Regulations.
- b. Excavations Deeper than Four Feet. If work under this Contract involves digging trenches or other excavation that extends deeper than four feet below the surface, Contractor shall promptly, and before the following conditions are disturbed, notify City, in writing, of any:
 - 1) Material that the Contractor believes may be material that is hazardous waste, as defined in Section 25117 of the Health and Safety Code that is required to be removed to a Class I, Class II, or Class III disposal site in accordance with provisions of existing law.

SECTION 00700
GENERAL CONDITIONS

- 2) Subsurface or latent physical conditions at the site differing from those indicated.
- 3) Unknown physical conditions at the site of any unusual nature, different materially from those ordinarily encountered and generally recognized as inherent in work of the character provided for in the Contract.

City shall promptly investigate the conditions, and if it finds that the conditions do so materially differ, or do involve hazardous waste, and cause a decrease or increase in Contractor's cost of, or the time required for, performance of any part of The Work, shall issue a change order under the procedures described in the Contract Documents.

In the event that a dispute arises between City and the Contractor as to whether the conditions materially differ, or involve hazardous waste, or cause a decrease or increase in the Contractor's cost of, or time required for, performance of any part of The Work, the Contractor shall not be excused from any scheduled completion date provided for by the Contract, but shall proceed with all Work to be performed under the Contract. Contractor shall retain any and all rights provided either by contract or by law which pertain to the resolution of disputes and protests between the parties.

ARTICLE 18. DIVERSION OF RECYCLABLE WASTE MATERIALS

Per the City's solid waste reduction and recycling requirements found in Chapter 8.69 of the Municipal Code of the City of San Clemente, the Contractor must reuse, recycle, or divert at least 75% of construction and demolition (C&D) debris generated on this project. Contractor must either: a) contract for solid waste handling services from the City's authorized franchise solid waste hauler (CR&R Waste Services, www.crrwasteservices.com, 877-728-0446) and provide written evidence that the City's franchise waste hauler will be providing C&D material collection services to Contractor for this project; or b) submit a Waste Management Plan and associated fee and deposit per the Waste Management Plan requirements found in Appendix 2. All costs incurred for these waste diversion efforts shall be the responsibility of the Contractor.

ARTICLE 19. REMOVAL OF HAZARDOUS MATERIALS

Should Contractor encounter material reasonably believed to be polychlorinated biphenyl (PCB) or other toxic wastes and hazardous materials which have not been rendered harmless at the Project site, the Contractor shall immediately stop work at the affected Project site and shall report the condition to City in writing. City shall contract for any services required to directly remove and/or abate PCBs and other toxic wastes and hazardous materials, if required by the Project site(s), and shall not require the Contractor to subcontract for such services. The Work in the affected area shall not thereafter be resumed except by written agreement of City and Contractor.

ARTICLE 20. SANITARY FACILITIES

Contractor shall provide sanitary temporary toilet buildings for the use of all workers. All toilets shall comply with all applicable federal, state and local laws, codes, ordinances, and regulations. Toilets shall be kept supplied with toilet paper and shall have workable door fasteners. Toilets shall be serviced no less than once weekly and shall be present in a quantity of not less than 1 per 20 workers as required by CAL-OSHA regulation. The toilets shall be maintained in a sanitary

SECTION 00700
GENERAL CONDITIONS

condition at all times. Use of toilet facilities in The Work under construction shall not be permitted. Any other Sanitary Facilities required by CAL-OSHA shall be the responsibility of the Contractor.

ARTICLE 21. AIR POLLUTION CONTROL

Contractor shall comply with all air pollution control rules, regulations, ordinances and statutes. All containers of paint, thinner, curing compound, solvent or liquid asphalt shall be labeled to indicate that the contents fully comply with the applicable material requirements.

Without limiting the foregoing, Contractor must fully comply with all applicable laws, rules and regulations in furnishing or using equipment and/or providing services, including, but not limited to, emissions limits and permitting requirements imposed by the South Coast Air Quality Management District (SCAQMD) and/or California Air Resources Board (CARB). Although the SCAQMD and CARB limits and requirements are broader, Contractor shall specifically be aware of their application to "portable equipment", which definition is considered by SCAQMD and CARB to include any item of equipment with a fuel-powered engine. Contractor shall indemnify City against any fines or penalties imposed by SCAQMD, CARB, or any other governmental or regulatory agency for violations of applicable laws, rules and/or regulations by Contractor, its subcontractors, or others for whom Contractor is responsible under its indemnity obligations provided for in Article 50.

ARTICLE 22. WATER QUALITY MANAGEMENT AND COMPLIANCE

- a. Storm, surface, ground, nuisance, or other waters may be encountered at various times during the Work. Contractor hereby acknowledges that it has investigated the risk arising from such waters, has prepared its Bid accordingly, and assumes any and all risks and liabilities arising therefrom.
- b. Contractor shall keep itself and all subcontractors, staff, and employees fully informed of and in compliance with all local, state and federal laws, rules and regulations that may impact, or be implicated by the performance of the Work including, without limitation, all applicable provisions of the City's ordinances regulating discharges of storm water; the Federal Water Pollution Control Act (33 U.S.C. § 1251 et seq.); the California Porter-Cologne Water Quality Control Act (Water Code § 13000 et seq.); and any and all regulations, policies, or permits issued pursuant to any such authority. These include, but are not limited to San Diego Regional Water Quality Control Board Order No. R9-2013-0001 as amended by Order Nos. R9-2015-0001 and R9-2015-0100, and State Water Resources Control Board Order No. 2009-0009-DWQ as amended by Order Nos. 2010-0014-DWQ and Order No. 2012-0006-DWQ, and any amendment or renewal thereof.
- c. Contractor shall comply with the lawful requirements of the City, and any other municipality, drainage district, or other local agency with jurisdiction over the location where the Work is to be conducted, regarding discharges of storm water to separate storm drain systems or watercourses. These requirements include but are not limited to, all applicable requirements of the Orange County Drainage Area Management Plan ("DAMP"), the South Orange County Water Quality Improvement Plan ("WQIP"), and the City of San Clemente Jurisdictional Runoff Management Plan ("JRMP"), and the applicable Water Quality Management Plan

SECTION 00700
GENERAL CONDITIONS

("WQMP") for this project, if any. Sections 5, 7, and 8 of the DAMP contain requirements related to design and construction of public projects. Contractor shall be familiar the DAMP, WQIP, JRMP and any applicable WQMP, and shall comply with the requirements as specified therein. In the event these documents are revised or replaced in accordance with the requirements of a state or federal law, rule or permit that impacts the performance of the Work, Contractor shall comply with the revised or replaced requirements. Electronic copies of the DAMP, WQIP and JRMP are available online as follows:

DAMP: www.ocwatersheds.com/documents/damp

WQIP:

[www.ocwatersheds.com/documents/south_oc_water_quality_improvement_plan_\(wqip\)](http://www.ocwatersheds.com/documents/south_oc_water_quality_improvement_plan_(wqip))

JRMP: www.san-clemente.org/department-services/environmental-services/water-quality/local-implementation-plan

- d. Contractor shall comply with all aspects of the State Water Resources Control Board ("State Board") Water Quality Order No. 2009-0009-DWQ, National Pollutant Discharge Elimination System General Permit for Storm Water Discharges Associated with Construction Activity, including any amendment or renewal thereof, ("Construction General Permit") for all projects that involve construction on or disturbance of one acre or more of land or which are part of a larger common area of development.
- e. City may require Contractor to file the Notice of Intent ("NOI") and obtain coverage for the Project under the Construction General Permit. This may include filing all necessary documentation including the Permit Registration Documents ("PRDs") through the Stormwater Multiple Applications and Report Tracking System ("SMARTS"); preparing and implementing a Storm Water Pollution Prevention Plan ("SWPPP") for the Work site; implementing all other provisions, and monitoring and reporting requirements required by the Construction General Permit; and providing a Qualified SWPPP Developer ("QSD") and Qualified SWPPP Practitioner ("QSP"), as necessary for all Work site activities, including but not limited to preparation and submittal of all reports, plans, inspections, and monitoring information in compliance with the Construction General Permit. City retains the right to develop its own documentation for the project site, including but not limited to the SWPPP, and in the alternative may require Contractor to adopt and implement portions of the City developed SWPPP. Specific requirements for the Work site shall be set forth in the Special Conditions. Contractor shall include all costs of compliance with specified requirements in the Contract amount.
- f. For those Work sites where construction activity results in the disturbance of less than one acre of total land area and/or do not need coverage under the Construction General Permit, the Contractor shall be responsible for preparing and implementing an Erosion and Sediment Control Plan in accordance with San Diego Regional Water Quality Control Board Order No. R9-2013-0001 as amended by Order Nos. R9-2015-0001 and R9-2015-0100 and any amendment or renewal

SECTION 00700
GENERAL CONDITIONS

thereof, and the City's LIP and Orange County DAMP and any revision or replacement thereof.

- g. Notwithstanding the above, before any PRDs, SWPPP, or other Construction General Permit related document may be submitted to the State Water Resources Control Board or implemented on the Work site, it must first be reviewed and approved by the City and/or the City's designee. The City expressly reserves the right to procure coverage under the Construction General Permit for the Work site if Contractor fails to draft satisfactory PRDs or SWPPP or otherwise fails to proceed in a manner that complies with the requirements of the Construction General Permit. The City additionally reserves the right to hire additional contractors to maintain compliance at the Work site. Whether Contractor has adequately maintained compliance with the Construction General Permit shall be the City's sole determination. Any costs incurred by the City in procuring coverage under the Construction General Permit, or drafting and/or implementing a SWPPP for the Work site shall be paid by Contractor.
- h. Failure to comply with laws, regulations, and ordinances listed in this Article 22 is a violation of federal and state law. Notwithstanding any other indemnity contained in this Agreement, Contractor agrees to indemnify and hold harmless the City, its officials, officers, agents, employees and authorized volunteers from and against any and all claims, demands, losses or liabilities of any kind or nature which the City, its officials, officers, agents, employees and authorized volunteers may sustain or incur for noncompliance with the laws, regulations, and ordinances listed above, arising out of or in connection with the Work, except for liability resulting from the sole established negligence, willful misconduct or active negligence of the City, its officials, officers, agents, employees or authorized volunteers.
- i. City reserves the right to defend any enforcement action or civil action brought against the City for Contractor's failure to comply with any applicable water quality law, regulation, or policy. Contractor hereby agrees to be bound by, and to reimburse the City for the costs associated with, any enforcement action and/or settlement reached between the City and any relevant enforcement entity.
- j. City may seek damages from Contractor for delay in completing the Work in accordance with the Contract Documents, caused by Contractor's failure to comply with the laws, regulations and policies described in this Article 22, or any other relevant water quality law, regulation, or policy.

ARTICLE 23. CLEANING UP

- a. Contractor at all times shall keep premises free from debris such as waste, rubbish, and excess materials and equipment. Contractor shall not store debris under, in, or about the premises. Upon completion of Work, Contractor shall clean the interior and exterior of the building or improvement including fixtures, equipment, walls, floors, ceilings, roofs, window sills and ledges, horizontal projections, and any areas where debris has collected so surfaces are free from foreign material or discoloration. Contractor shall clean and polish all glass, plumbing fixtures, and finish hardware and similar finish surfaces and equipment and contractor shall also remove temporary fencing, barricades, planking and construction toilet and similar

SECTION 00700
GENERAL CONDITIONS

temporary facilities from site. Contractor shall also clean all buildings, asphalt and concrete areas to the degree necessary to remove oil, grease, fuel, or other stains caused by Contractor operations or equipment.

- b. Contractor shall fully clean up the site at the completion of The Work. If the Contractor fails to immediately clean up at the completion of The Work, City may do so and the cost of such clean up shall be charged back to the Contractor.

ARTICLE 24. LAYOUT AND FIELD ENGINEERING

All field engineering required for laying out The Work and establishing grades for earthwork operations, location and alignment of any and all site elements (buildings, paving, walks, fencing, furnishings, etc.) shall be furnished by the Contractor at its expense. A digital AutoCAD (version 2017) file shall be provided to the Contractor by the City indicating the location and layout of all site elements for the use by the Contractors surveyor. Layout shall be done by a registered civil engineer or a licensed land surveyor Approved by the Engineer. Any surveying necessary to establish the grade and line of the work is to be done by a properly licensed land surveyor retained by the contractor. Any required "as-built" drawings of the Work shall be prepared by the registered civil engineer.

ARTICLE 25. EXCESSIVE NOISE

- a. The Contractor shall use only such equipment on the work and in such state of repair so that the emission of sound therefrom is within the noise tolerance level of that equipment as established by CAL-OSHA.
- b. The Contractor shall comply with the most restrictive of the following: (1) local sound control and noise level rules, regulations and ordinances and (2) the requirements contained in these Contract Documents, including hours of operation requirements. No internal combustion engine shall be operated on the Project without a muffler of the type recommended by the manufacturer. Should any muffler or other control device sustain damage or be determined to be ineffective or defective, the Contractor shall promptly remove the equipment and shall not return said equipment to the job until the device is repaired or replaced. Said noise and vibration level requirements shall apply to all equipment on the job or related to the job, including but not limited to, trucks, transit mixers or transit equipment that may or may not be owned by the Contractor.

ARTICLE 26. TESTS AND INSPECTIONS

- a. If the Contract Documents, the Engineer, or any instructions, laws, ordinances, or public authority require any part of The Work to be tested or Approved, Contractor shall provide the Engineer at least two (2) working days notice of its readiness for observation or inspection. If inspection is by a public authority other than City, Contractor shall promptly inform City of the date fixed for such inspection. Required certificates of inspection (or similar) shall be secured by Contractor. Costs for City testing and City inspection shall be paid by City. Costs of tests for Work found not to be in compliance shall be paid by the Contractor.

SECTION 00700
GENERAL CONDITIONS

- b. If any Work is done or covered up without the required testing or approval, the Contractor shall uncover or deconstruct the Work, and the Work shall be redone after completion of the testing at the Contractor's cost in compliance with the Contract Documents.
- c. Where inspection and testing are to be conducted by an independent laboratory or agency, materials or samples of materials to be inspected or tested shall be selected by such laboratory or agency, or by City, and not by Contractor. All tests or inspections of materials shall be made in accordance with the commonly recognized standards of national organizations.
- d. In advance of manufacture of materials to be supplied by Contractor which must be tested or inspected, Contractor shall notify City so that City may arrange for testing at the source of supply. Any materials which have not satisfactorily passed such testing and inspection shall not be incorporated into The Work.
- e. If the manufacture of materials to be inspected or tested will occur in a plant or location outside the geographic limits of City, the Contractor shall pay for any excessive or unusual costs associated with such testing or inspection, including but not limited to excessive travel time, standby time and required lodging.
- f. Reexamination of Work may be ordered by City. If so ordered, Work must be uncovered or deconstructed by Contractor. If Work is found to be in accordance with the Contract Documents, City shall pay the costs of reexamination and reconstruction. If such work is found not to be in accordance with the Contract Documents, Contractor shall pay all costs.

ARTICLE 27. PROTECTION OF WORK AND PROPERTY

- a. Contractor acknowledges and agrees that public safety is of utmost importance, and Contractor agrees that during the progress of the Work Contractor shall constantly protect and preserve the safety of the public. Contractor shall not unnecessarily cause inconvenience to the public during the progress of the Work and shall minimize the inconvenience caused by Contractor's operations. Such operations include, but are not limited to, work performed on or adjacent to the Work site, traffic lane and pedestrian closures and deliveries of material and equipment.
- b. The Contractor shall be responsible for all damages to persons or property that occur as a result of The Work. Contractor shall be responsible for the proper care and protection of all materials delivered and Work performed until completion and final Acceptance by City. All Work shall be solely at the Contractor's risk. Contractor shall adequately protect adjacent property from settlement or loss of lateral support as necessary. Contractor shall comply with all applicable safety laws and building codes to prevent accidents or injury to persons on, about, or adjacent to the Project site where Work is being performed. Contractor shall erect and properly maintain at all times, as required by field conditions and progress of work, all necessary safeguards, signs, barriers, lights, and watchmen for protection of workers and the public, and shall post danger signs warning against hazards created in the course of construction.

SECTION 00700
GENERAL CONDITIONS

- c. In an emergency affecting safety of life or of work or of adjoining property, Contractor, without special instruction or authorization from the Engineer, is hereby permitted to act to prevent such threatened loss or injury; and Contractor shall so act, without appeal, if so authorized or instructed by the Engineer or City. Any compensation claimed by Contractor on account of emergency work shall be determined by and agreed upon by City and the Contractor.
- d. Contractor shall provide such heat, covering, and enclosures as are necessary to protect all Work, materials, equipment, appliances, and tools against damage by weather conditions.
- e. Contractor shall take adequate precautions to protect existing sidewalks, curbs, pavements, utilities, and other adjoining property and structures, and to avoid damage thereto, and Contractor shall repair any damage thereto caused by The Work operations. Contractor shall:
 - 1) Enclose the working area with a substantial barricade, and arrange work to cause minimum amount of inconvenience and danger to the public.
 - 2) Provide substantial barricades around any shrubs or trees indicated to be preserved.
 - 3) Deliver materials to the Project site over a route designated by the Engineer.
 - 4) Provide any and all dust control required and follow the Applicable air quality regulations as appropriate. If the Contractor does not comply, City shall have the immediate authority to provide dust control and deduct the cost from payments to the Contractor.
 - 5) Confine Contractor's apparatus, the storage of materials, and the operations of its workers to limits required by law, ordinances, permits, or directions of the Engineer. Contractor shall not unreasonably encumber the Project site with its materials.
 - 6) Take care to prevent disturbing or covering any survey markers, monuments, or other devices marking property boundaries or corners. If such markers are disturbed by accident, they shall be replaced by an approved civil engineer or land surveyor, at no cost to City.
 - 7) Ensure that existing facilities, fences and other structures are all adequately protected and that, upon completion of all Work, all facilities that may have been damaged are restored to a condition acceptable to City.
 - 8) Preserve and protect from injury all buildings, pole lines and all direction, warning and mileage signs that have been placed within the right-of-way.
 - 9) At the completion of work each day, leave the Project site in a clean, safe condition.

SECTION 00700
GENERAL CONDITIONS

- 10) Comply with any stage construction and traffic handling plans. Access to residences and businesses shall be maintained at all times.

- f. These precautionary measures will apply continuously and not be limited to normal working hours. Full compensation for the Work involved in the preservation of life, safety and property as above specified shall be considered as included in the prices paid for the various contract items of Work, and no additional allowance will be made therefor.

- g. Should damage to persons or property occur as a result of The Work, Contractor shall be responsible for proper investigation, documentation, including video or photography, to adequately memorialize and make a record of what transpired. City shall be entitled to inspect and copy any such documentation, video, or photographs.

ARTICLE 28. CONTRACTORS MEANS AND METHODS

Contractor is solely responsible for the means and methods utilized to Perform The Work. In no case shall the Contractor's means and methods deviate from commonly used industry standards.

ARTICLE 29. INSPECTOR'S FIELD OFFICE

"NOT APPLICABLE"

ARTICLE 30. AUTHORIZED REPRESENTATIVES

City shall designate representatives, who shall have the right to be present at the Project site at all times. City may designate an inspector who shall have the right to observe all of the Contractor's Work. The inspector is not authorized to make changes in the Contract Documents. The inspector shall not be responsible for the Contractor's failure to carry out The Work in accordance with the Contract Documents. Contractor shall provide safe and proper facilities for such access.

ARTICLE 31. HOURS OF WORK

- a. Eight (8) hours of work shall constitute a legal day's work. The Contractor and each subcontractor shall forfeit, as penalty to City, twenty-five dollars (\$25) for each worker employed in the execution of Work by the Contractor or any subcontractor for each day during which such worker is required or permitted to work more than eight (8) hours in any one day and forty (40) hours in any week in violation of the provisions of the Labor Code, and in particular, Section 1810 to Section 1815, except as provided in Labor Code Section 1815.

- b. Unless otherwise provided in the Special Conditions, Work shall be accomplished on a regularly scheduled eight (8) hour per day work shift basis, Monday through Friday, between the hours of 8:00 a.m. and 4:30 p.m.

- c. It shall be unlawful for any person to operate, permit, use, or cause to operate any of the following at the Project site, other than between the hours of 8:00 a.m. to

SECTION 00700
GENERAL CONDITIONS

4:30 p.m., Monday through Friday, with no Work allowed on City-observed holidays, unless otherwise Approved by the Engineer:

- 1) Powered Vehicles
- 2) Construction Equipment
- 3) Loading and Unloading Vehicles
- 4) Domestic Power Tool.

ARTICLE 32. PAYROLL RECORDS

- a. Pursuant to Labor Code Section 1776, the Contractor and each subcontractor shall maintain weekly certified payroll records showing the name, address, social security number, work classification, straight time and overtime hours paid each day and week, and the actual per diem wages paid to each journeyman, apprentice, worker or other employee employed in connection with the work. Contractor shall certify under penalty of perjury that records maintained and submitted by Contractor are true and accurate. Contractor shall also require subcontractor(s) to certify weekly payroll records under penalty of perjury.
- b. In accordance with Labor Code section 1771.4, the Contractor and each subcontractor shall furnish the certified payroll records directly to the Department of Industrial Relations ("DIR") on a weekly basis and in the format prescribed by the DIR, which may include electronic submission. Contractor shall comply with all requirements and regulations from the DIR relating to labor compliance monitoring and enforcement.
- c. The payroll records described herein shall be certified and submitted by the Contractor at a time designated by City. The Contractor shall also provide the following:
 - 1) A certified copy of the employee's payroll records shall be made available for inspection or furnished to such employee or his or her authorized representative on request.
 - 2) A certified copy of all payroll records described herein shall be made available for inspection or furnished upon request of the Department of Industrial Relations ("DIR").
- d. The certified payroll records shall be on forms provided by the Division of Labor Standards Enforcement ("DLSE") of the DIR or shall contain the same information as the forms provided by the DLSE.
- e. Any copy of records made available for inspection and furnished upon request to the public shall be marked or obliterated in such a manner as to prevent disclosure of an individual's name, address, and social security number. The name and address of the Contractor or any subcontractor shall not be marked or obliterated.

SECTION 00700
GENERAL CONDITIONS

- f. In the event of noncompliance with the requirements of this Section, the Contractor shall have ten (10) days in which to comply subsequent to receipt of written notice specifying any item or actions necessary to ensure compliance with this section. Should noncompliance still be evident after such ten (10) day period, the Contractor shall, as a penalty to City, forfeit one hundred dollars (\$100.00) for each day, or portion thereof, for each worker until strict compliance is effectuated. Upon the request of the DIR, such penalties shall be withheld from contract payments.

ARTICLE 33. PREVAILING RATES OF WAGES

- a. The Contractor is aware of the requirements of Labor Code Sections 1720 et seq. and 1770 et seq., as well as California Code of Regulations, Title 8, Section 16000 et seq. ("Prevailing Wage Laws"), which require the payment of prevailing wage rates and the performance of other requirements on certain "public works" and "maintenance" projects. Since this Project involves an applicable "public works" or "maintenance" project, as defined by the Prevailing Wage Laws, and since the total compensation is \$1,000 or more, Contractor agrees to fully comply with such Prevailing Wage Laws. The Contractor shall obtain a copy of the prevailing rates of per diem wages at the commencement of this Agreement from the website of the Division of Labor Statistics and Research of the Department of Industrial Relations located at www.dir.ca.gov/dlsr/. In the alternative, the Contractor may view a copy of the prevailing rates of per diem wages at City. Contractor shall make copies of the prevailing rates of per diem wages for each craft, classification or type of worker needed to perform work on the Project available to interested parties upon request, and shall post copies at the Contractor's principal place of business and at the Project site. Contractor shall defend, indemnify and hold City, its elected officials, officers, employees and agents free and harmless from any claims, liabilities, costs, penalties or interest arising out of any failure or alleged failure to comply with the Prevailing Wage Laws.
- b. The Contractor and each subcontractor shall forfeit as a penalty to City not more than two hundred dollars (\$200) for each calendar day, or portion thereof, for each worker paid less than the stipulated prevailing wage rate for any work done by him, or by any subcontract under him, in violation of the provisions of the Labor Code. The difference between such stipulated prevailing wage rate and the amount paid to each worker for each calendar day or portion thereof for which each worker was paid less than the stipulated prevailing wage rate shall be paid to each worker by the Contractor.
- c. Contractor shall post, at appropriate conspicuous points on the Project site, a schedule showing all determined general prevailing wage rates and all authorized deductions, if any, from unpaid wages actually earned.

ARTICLE 34. EMPLOYMENT OF APPRENTICES

The Contractor's attention is directed to the provisions of Sections 1777.5, 1777.6, and 1777.7 of the Labor Code concerning employment of apprentices by the Contractor or any subcontractor. The Contractor shall obtain a certificate of apprenticeship before employing any apprentice pursuant to Section 1777.5, 1777.6, and 1777.7 of the Labor Code. Information relative to apprenticeship standards, wage schedules, and other requirements may be obtained from the

SECTION 00700
GENERAL CONDITIONS

Director of Industrial Relations, the Administrator of Apprenticeships, San Francisco, California, or from the Division of Apprenticeship Standards and its branch offices.

ARTICLE 35. CONTRACTOR AND SUBCONTRACTOR REGISTRATION

Pursuant to Labor Code sections 1725.5 and 1771.1, the Contractor and its subcontractors must be registered with the Department of Industrial Relations (“DIR”) at the time of the bid. By entering into this Contract, Contractor represents that it is aware of the registration requirement and is currently registered with the DIR. Contractor shall remain a current registration for the duration of the Project. Contractor shall further include the requirements of Labor Code sections 1725.5 and 1771.1 in any subcontract and ensure that all subcontractors are registered at the time this Contract is entered into and maintain registration for the duration of the Project.

ARTICLE 36. LABOR COMPLIANCE; STOP ORDERS

This Project is subject to compliance monitoring and enforcement by the DIR. It shall be the Contractor’s sole responsibility to evaluate and pay the cost of complying with all labor compliance requirements under this Contract and applicable law. Any stop orders issued by the DIR against Contractor or any subcontractor that affect Contractor’s performance of Work, including any delay, shall be Contractor’s sole responsibility. Any delay arising out of or resulting from such stop orders shall be considered Contractor caused delay subject to any applicable liquidated damages and shall not be compensable by the City. Contractor shall defend, indemnify and hold the City, its officials, officers, employees and agents free and harmless from any claim or liability arising out of stop orders issued by the DIR against Contractor or any subcontractor.

ARTICLE 37. NONDISCRIMINATION/EQUAL EMPLOYMENT OPPORTUNITY

Pursuant to Labor Code Section 1735 and other applicable provisions of law, the Contractor and its subcontractors shall not discriminate against any employee or applicant for employment because of race, color, religion, sex, national origin, age, political affiliation, marital status, or handicap on this Project. The Contractor will take affirmative action to insure that employees are treated during employment or training without regard to their race, color, religion, sex, national origin, age, political affiliation, marital status, or handicap.

ARTICLE 38. LABOR/EMPLOYMENT SAFETY

The Contractor shall maintain emergency first aid treatment for his employees which complies with the Federal Occupational Safety and Health Act of 1970 (29 U.S.C. § 651 et seq.), and California Code of Regulations, Title 8, Industrial Relations Division 1, Department of Industrial Relations, Chapter 4.

ARTICLE 39. INSURANCE

Contractor agrees to procure and maintain, at Contractor’s expense all insurance specified in Appendix “1” attached hereto and by this reference incorporated herein. Contractor shall require all subcontractors to carry the same policies and limits of insurance that the Contractor is required to maintain, unless otherwise approved in writing by the City.

ARTICLE 40. TIME FOR COMPLETION AND LIQUIDATED DAMAGES

- a. Time for Completion/Liquidated Damages. Contractor shall commence work within ten (10) days of the date stated in City's Notice to Proceed and shall diligently and continuously prosecute the work to completion in the time specified in the Contract Documents. City is under no obligation to consider early completion of the Project; and the Contract completion date shall not be amended by City's receipt or acceptance of the Contractor's proposed earlier completion date. Furthermore, Contractor shall not, under any circumstances, receive additional compensation from City (including but not limited to indirect, general, administrative or other forms of overhead costs) for the period between the time of earlier completion proposed by the Contractor and the Contract completion date. If The Work is not completed as stated in the Contract Documents, it is understood that City will suffer damage. In accordance with Government Code section 53069.85, being impractical and infeasible to determine the amount of actual damage, it is agreed that Contractor shall pay to City as fixed and liquidated damages, and not as a penalty, the sum stipulated in the Contract for each day of delay until The Work is fully completed. Contractor and its surety shall be liable for any liquidated damages. Any money due or to become due the Contractor may be retained to cover liquidated damages.
- b. Inclement Weather. Contractor shall abide the Engineer's determination of what constitutes inclement weather. Time extensions for inclement weather shall only be granted when the Work stopped during inclement weather is on the critical path of the Project schedule.
- c. Extension of Time. Contractor shall not be charged liquidated damages because of any delays in completion of The Work due to unforeseeable causes beyond the control and without the fault or negligence of Contractor (or its subcontractors or suppliers). Contractor shall within five (5) Days of identifying any such delay notify City in writing of causes of delay. City shall ascertain the facts and extent of delay and grant extension of time for completing The Work when, in its judgment, the facts justify such an extension. Time extensions to the Project shall be requested by the Contractor as they occur and without delay. No delay claims shall be permitted unless the event or occurrence delays the completion of the Project beyond the Contract completion date.
- d. No Damages for Reasonable Delay. City's liability to Contractor for delays for which City is responsible shall be limited to only an extension of time unless such delays were unreasonable under the circumstances. In no case shall City be liable for any costs which are borne by the Contractor in the regular course of business, including, but not limited to, home office overhead and other ongoing costs. Damages caused by unreasonable City delay, including delays caused by items that are the responsibility of City pursuant to Government Code section 4215, shall be based on actual costs only, no proportions or formulas shall be used to calculate any delay damages.

ARTICLE 41. COST BREAKDOWN AND PERIODIC ESTIMATES

Contractor shall furnish on forms Approved by City:

SECTION 00700
GENERAL CONDITIONS

- a. Within ten (10) Days of award of the Contract a detailed estimate giving a complete breakdown of the Contract price;
- b. A monthly itemized estimate of Work done for the purpose of making progress payments. In order for City to consider and evaluate each progress payment application, the Contractor shall submit a detailed measurement of Work performed and a progress estimate of the value thereof before the tenth (10th) Day of the following month.
- c. Contractor shall submit, with each of its payment requests, an adjusted list of actual quantities, verified by the Engineer, for unit price items listed, if any, in the Bid Form.
- d. Following City's Acceptance of the Work, the Contractor shall submit to City a written statement of the final quantities of unit price items for inclusion in the final payment request.
- e. City shall have the right to adjust any estimate of quantity and to subsequently correct any error made in any estimate for payment.

Contractor shall certify under penalty of perjury, that all cost breakdowns and periodic estimates accurately reflect the Work on the Project.

ARTICLE 42. MOBILIZATION

- a. When a bid item is included in the Bid Form for mobilization, the costs of Work in advance of construction operations and not directly attributable to any specific bid item will be included in the progress estimate ("Initial Mobilization"). When no bid item is provided for "Initial Mobilization," payment for such costs will be deemed to be included in the other items of The Work.
- b. Payment for Initial Mobilization based on the lump sum provided in the Bid Form, which shall constitute full compensation for all such Work. No payment for Initial Mobilization will be made until all of the listed items have been completed to the satisfaction of the Engineer. The scope of the Work included under Initial Mobilization shall include, but shall not be limited to, the following principal items:
 - 1) Obtaining and paying for all bonds, insurance, and permits.
 - 2) Moving on to the Project site of all Contractor's plant and equipment required for first month's operations.
 - 3) Installing temporary construction power, wiring, and lighting facilities.
 - 4) Establishing fire protection system.
 - 5) Developing and installing a construction water supply.
 - 6) Providing and maintaining the field office trailers for the Contractor and the Engineer, complete, with all specified furnishings and utility services

SECTION 00700
GENERAL CONDITIONS

including telephones, telephone appurtenances, computer and printer, and copying machine.

- 7) Providing on-site communication facilities for the Owner and the Engineer, including telephones, radio pagers, and fax machines.
- 8) Providing on-site sanitary facilities and potable water facilities as specified per Cal-OSHA and these Contract Documents.
- 9) Furnishing, installing, and maintaining all storage buildings or sheds required for temporary storage of products, equipment, or materials that have not yet been installed in the Work. All such storage shall meet manufacturer's specified storage requirements, and the specific provisions of the specifications, including temperature and humidity control, if recommended by the manufacturer, and for all security.
- 10) Arranging for and erection of Contractor's work and storage yard.
- 11) Posting all OSHA required notices and establishment of safety programs per Cal-OSHA.
- 12) Full-time presence of Contractor's superintendent at the job site as required herein.
- 13) Submittal of Construction Schedule as required by the Contract Documents.

ARTICLE 43. PAYMENTS

- a. City shall make monthly progress payments following receipt of undisputed and properly submitted payment requests. Contractor shall be paid a sum equal to ninety-five percent (95%) of the value of Work performed up to the last day of the previous month, less the aggregate of previous payments, except where the City has adopted a finding that the Work done under the Contract is substantially complex, and then the Contractor shall be paid a sum equal to ninety percent (90%) of the value of the Work performed up to the last day of the previous month, less the aggregate of previous payments.
- b. The Contractor shall, after the full completion of The Work, submit a final payment application. All prior progress estimates shall be subject to correction in the final estimate and payment.
- c. Unless otherwise required by law, the final payment of five percent (5%) of the value of the Work (or ten percent (10%) in the event the City has adopted a finding that the Work under the Contract is substantially complex), if unencumbered, shall be paid no later than sixty (60) Days after the date of recordation of the Notice of Completion.
- d. Acceptance by Contractor of the final payment shall constitute a waiver of all claims against City arising from this Contract.

SECTION 00700
GENERAL CONDITIONS

- e. Payments to the Contractor shall not be construed to be an acceptance of any defective work or improper materials, or to relieve the Contractor of its obligations under the Contract Documents.
- f. The Contractor shall submit with each payment request the Contractor's conditional waiver of lien for the entire amount covered by such payment request, as well as a valid unconditional waiver of lien from the Contractor and all subcontractors and materialmen for all work and materials included in any prior invoices. Waivers of lien shall be in the forms prescribed by California Civil Code Section 8132. Prior to final payment by City, the Contractor shall submit a final waiver of lien for the Contractor's work, together with releases of lien from any subcontractor or materialmen.

ARTICLE 44. PAYMENTS WITHHELD AND BACK CHARGES

- a. In addition to amounts which City may retain under other provisions of the Contract Documents City may withhold payments due to Contractor as may be necessary to cover:
 - 1) Stop Notice Claims.
 - 2) Defective work not remedied.
 - 3) Failure of Contractor to make proper payments to its subcontractors or suppliers.
 - 4) Completion of the Contract if there exists a reasonable doubt that the work can be completed for balance then unpaid.
 - 5) Damage to another contractor or third party.
 - 6) Amounts which may be due City for claims against Contractor.
 - 7) Failure of Contractor to keep the record ("as-built") drawings up to date.
 - 8) Failure to provide updates on the construction schedule.
 - 9) Site clean up.
 - 10) Failure of the Contractor to comply with requirements of the Contract Documents.
 - 11) Liquated damages.
 - 12) Legally permitted penalties.
- b. Upon completion of the Contract, City will reduce the final Contract amount to reflect costs charged to the Contractor, backcharges or payments withheld pursuant to the Contract Documents.

ARTICLE 45. CHANGES AND EXTRA WORK

- a. Change Order Work.
- 1) City, without invalidating the Contract, may order changes in the Work consisting of additions, deletions or other revisions, the Contract amount and Contract time being adjusted accordingly. All such changes in the Work shall be authorized by Change Order, shall be performed under the applicable conditions of the Contract Documents, and shall be subject to the approval authority requirements of Article 4 of the Contract. A Change Order signed by the Contractor indicates the Contractor's agreement therewith, including any adjustment in the Contract amount or the Contract time, and the full and final settlement of all costs (direct, indirect and overhead) related to the Work authorized by the Change Order.
 - 2) All claims for additional compensation to the Contractor shall be presented in writing before the expense is incurred and will be adjusted as provided herein. No work shall be allowed to lag pending such adjustment, but shall be promptly executed as directed, even if a dispute arises. No claim will be considered after the work in question has been done unless a written contract change order has been issued or a timely written notice of claim has been made by Contractor. Contractor shall not be entitled to claim or bring suit for damages, whether for loss of profits or otherwise, on account of any decrease or omission of any item or portion of Work to be done. Whenever any change is made as provided for herein, such change shall be considered and treated as though originally included in the Contract, and shall be subject to all terms, conditions and provisions of the original Contract.
 - 3) Owner Initiated Change. The Contractor must submit a complete cost proposal, including any change in the Contract time, within seven (7) Days after receipt of a scope of a proposed change order, unless City requests that proposals be submitted in less than seven (7) Days.
 - 4) Contractor Initiated Change. The Contractor must give written notice of a proposed change order required for compliance with the Contract Documents within seven (7) Days of discovery of the facts giving rise to the proposed change order.
 - 5) Whenever possible, any changes to the Contract amount shall be in a lump sum mutually agreed to by the Contractor and City.
 - 6) Price quotations from the Contractor shall be accompanied by sufficiently detailed supporting documentation to permit verification by City.
 - 7) If the Contractor fails to submit the cost proposal within the seven (7) Day period (or as requested), City has the right to order the Contractor in writing to commence the work immediately on a force account basis and/or issue a lump sum change to the contract price in accordance with City's estimate of cost. If the change is issued based on City estimate, the Contractor will

SECTION 00700
GENERAL CONDITIONS

waive its right to dispute the action unless within fifteen (15) Days following completion of the added/deleted work, the Contractor presents written proof that City's estimate was in error.

- 8) Estimates for lump sum quotations and accounting for cost-plus-percentage work shall be limited to direct expenditures necessitated specifically by the subject extra work, and shall be segregated as follows:
- (a) Labor. The costs of labor will be the actual cost for wages prevailing locally for each craft or type of worker at the time the extra work is done, plus employer payments of payroll taxes and insurance, health and welfare, pension, vacation, apprenticeship funds, and other direct costs resulting from Federal, State or local laws, as well as assessment or benefits required by lawful collective bargaining agreements. The use of a labor classification which would increase the extra work cost will not be permitted unless the contractor establishes the necessity for such additional costs. Labor costs for equipment operators and helpers shall be reported only when such costs are not included in the invoice for equipment rental.
 - (b) Materials. The cost of materials reported shall be at invoice or lowest current price at which such materials are locally available in the quantities involved, plus sales tax, freight and delivery. Materials cost shall be based upon supplier or manufacturer's invoice. If invoices or other satisfactory evidence of cost are not furnished within fifteen (15) Days of delivery, then the Engineer shall determine the materials cost, at its sole discretion.
 - (c) Tool and Equipment Use. No payment will be made for the use of small tools, tools which have a replacement value of \$1,000 or less. Regardless of ownership, the rates to be used in determining equipment use costs shall not exceed listed rates prevailing locally at equipment rental agencies, or distributors, or Caltrans Equipment Rental Rates (without surcharge) at the time the work is performed.
 - (d) Overhead, Profit and Other Charges. The markup for overhead (including supervision) and profit on work added to the Contract shall be according to the following:
 - i. "Net Cost" is defined as consisting of costs of labor, materials and tools and equipment only excluding overhead and profit. The costs of applicable insurance and bond premium will be reimbursed to the Contractor and subcontractors at cost only, without mark-up.
 - ii. For Work performed by the Contractor's forces the added cost for overhead and profit shall not exceed fifteen percent (15%) of the Net Cost of the Work.

SECTION 00700
GENERAL CONDITIONS

- iii. For Work performed by a subcontractor, the added cost for overhead and profit shall not exceed fifteen percent (15%) of the Net Cost of the Work to which the Contractor may add five percent (5%) of the subcontractor's Net Cost.
 - iv. For Work performed by a subsubcontractor the added cost for overhead and profit shall not exceed fifteen percent (15%) of the Net Cost for Work to which the subcontractor and general contractor may each add an additional five percent (5%) of the Net Cost of the lower tier subcontractor.
 - v. No additional markup will be allowed for lower tier subcontractors, and in no case shall the added cost for overhead and profit payable by City exceed twenty-five percent (25%) of the Net Cost as defined herein.
- 9) All of the following costs are included in the markups for overhead and profit described above, and Contractor shall not receive any additional compensation for: Submittals, drawings: field drawings, Shop Drawings, including submissions of drawings; field inspection; General Superintendence; General administration and preparation of cost proposals, schedule analysis, Change Orders, and other supporting documentation; computer services; reproduction services; Salaries of project engineer, superintendent, timekeeper, storekeeper, and secretaries; Janitorial services; Small tools, incidentals and consumables; Temporary on Site facilities (Offices, Telephones, Internet access, Plumbing, Electrical Power, lighting; Platforms, Fencing, Water), Jobsite and Home office overhead or other expenses; vehicles and fuel used for work otherwise included in the Contract Documents; Surveying; Estimating; Protection of Work; Handling and disposal fees; Final cleanup; Other incidental Work; Related warranties.
- 10) For added or deducted Work by subcontractors, the Contractor shall furnish to City the subcontractor's signed detailed estimate of the cost of labor, material and equipment, including the subcontractor markup for overhead and profit. The same requirement shall apply to sub-subcontractors.
- 11) For added or deducted work furnished by a vendor or supplier, the Contractor shall furnish to City a detailed estimate or quotation of the cost to the Contractor, signed by such vendor or supplier.
- 12) Any change in The Work involving both additions and deletions shall indicate a net total cost, including subcontracts and materials. Allowance for overhead and profit, as specified herein, shall be applied if the net total cost is an extra; overhead and profit allowances shall not be applied if the net total cost is a credit. The estimated cost of deductions shall be based on labor and material prices on the date the Contract was executed.
- 13) Contractor shall not reserve a right to assert impact costs, extended job site costs, extended overhead, constructive acceleration and/or actual

SECTION 00700
GENERAL CONDITIONS

acceleration beyond what is stated in the change order for work. No claims shall be allowed for impact, extended overhead costs, constructive acceleration and/or actual acceleration due to a multiplicity of changes and/or clarifications. The Contractor may not change or modify City's change order form in an attempt to reserve additional rights.

- 14) If City disagrees with the proposal submitted by Contractor, it will notify the Contractor and City will provide its opinion of the appropriate price and/or time extension. If the Contractor agrees with City, a change order will be issued by City. If no agreement can be reached, City shall have the right to issue a unilateral change order setting forth its determination of the reasonable additions or savings in costs and time attributable to the extra or deleted work. Such determination shall become final and binding if the Contractor fails to submit a claim in writing to City within fifteen (15) Days of the issuance of the unilateral change order, disputing the terms of the unilateral change order.
- 15) No dispute, disagreement or failure of the parties to reach agreement on the terms of the change order shall relieve the Contractor from the obligation to proceed with performance of the work, including extra work, promptly and expeditiously.
- 16) Any alterations, extensions of time, extra work or any other changes may be made without securing consent of the Contractor's surety or sureties.

b. Contract Unit Prices

- 1) Increases more than twenty-five percent (25%) percent. Should the actual quantity of an item of work covered by a Contract Unit Price and constructed in conformance with the Plans and Specifications exceed the Bid quantity by more than twenty-five percent (25%), payment for the quantity in excess of one hundred twenty-five percent (125%) of the Bid quantity will be made on the basis of an adjustment in the Contract Unit Price mutually agreed to by the Contractor and the City, or at the option of the Engineer, on the basis of the Extra Work per paragraph (a) above.
- 2) Decreases of more than twenty-five percent (25%). Should the actual quantity of an item of work covered by a Contract Unit Price, and constructed in conformance with Plans and Specifications, be less than seventy-five percent (75%) of the Bid quantity, an adjustment in payment will not be made unless so requested in writing by the Contractor. If the Contractor so requests, payment will be made on the basis of an adjustment in the Contract Unit Price mutually agreed to by the Contractor and the City, or at the option of the Engineer, on the basis of the Extra Work per paragraph (a) above; however, in no case will payment be less than would be made for the actual quantity at the Contract Unit Price nor more than would be made for seventy-five percent (75%) of the Bid quantity at the Contract Unit Price.

ARTICLE 46. OCCUPANCY

City reserves the right to occupy or utilize any portion of The Work at any time before completion, and such occupancy or use shall not constitute Acceptance of any part of Work covered by this Contract. This use shall not relieve the Contractor of its responsibilities under the Contract.

ARTICLE 47. INDEMNIFICATION

- a. Contractor shall defend (with counsel of City Council's preference), indemnify and hold City, its officials, officers, agents, employees, and representatives free and harmless from any and all claims, demands, causes of action, costs, expenses, liabilities, losses, damages or injuries, in law or equity, regardless of whether the allegations are false, fraudulent, or groundless, to property or persons, including wrongful death, to the extent arising out of or incident to any acts, omissions or willful misconduct of Contractor, its officials, officers, employees, agents, consultants and contractors arising out of or in connection with the performance of the Work or this Contract, including claims made by subcontractors for nonpayment, including without limitation the payment of all consequential damages and attorneys fees and other related costs and expenses. To the fullest extent permitted by law, Contractor shall defend, at Contractor's own cost, expense and risk, with City Council's choosing, any and all such aforesaid suits, actions or other legal proceedings of every kind that may be brought or instituted against City, its officials, officers, agents, employees and representatives. To the extent of its liability, Contractor shall pay and satisfy any judgment, award or decree that may be rendered against City, its officials, officers, employees, agents, employees and representatives, in any such suit, action or other legal proceeding. Contractor shall reimburse City, its officials, officers, agents, employees and representatives for any and all legal expenses and costs incurred by each of them in connection therewith or in enforcing the indemnity herein provided. The only limitations on this provision shall be those imposed by Civil Code Section 2782.
- b. Contractor shall require each of its subcontractors to indemnify City to the same extent Contractor is indemnified.

ARTICLE 48. COMPLETION AND ACCEPTANCE, DEFECTIVE WORK

- a. Completion. Contractor shall make an initial request for final inspection after initial completion of the Work. After inspection, the Engineer will inform the Contractor, in writing, of all items found by Engineer to be incomplete or not in compliance with this Agreement. After the Contractor has completed these items, the procedure for final inspection shall then be the same as specified above for the Contractor's initial request for final inspection. If after two (2) "final" inspections, items are found by Engineer to be incomplete or not in compliance with this Agreement or any of the requirements contained or referenced herein, City may require Contractor, as a condition of City performing further field inspections, to submit to the Engineer a detailed written statement of the work performed subsequent to the date of the previous inspection at which such items were found to be incomplete or not in compliance with this Agreement.

The Parties shall follow the above steps until such time as Engineer determines that the Work has been satisfactorily completed in accordance with all terms and

SECTION 00700
GENERAL CONDITIONS

condition of this Agreement. Upon such determination, City shall order recordation of the Notice of Completion.

- b. Acceptance. Thirty-five (35) days after the Notice of Completion is recorded (or in the event any lien claims are filed against the Project arising out of Contractor's activities hereunder, on such date Contractor has finally satisfied, discharged, or obtained a release of such claim), City shall accept Contractor's Work.
- c. Defective Work. Contractor shall repair, reconstruct, replace or otherwise make acceptable any and all Work found by Engineer to be defective or not in accordance with the Agreement. Final acceptance of the Work shall not constitute a waiver by City of any defective work subsequently discovered.

ARTICLE 49. RECORD (“AS BUILT”) DRAWINGS

- a. Contractor shall prepare and maintain a complete set of record drawings (herein referred to as “as-builts”) and shall require each trade to prepare its own as-builts. The as-builts must show the entire site for each major trade, including but not limited to water, sewer, electrical, data, telephone, cable, fire alarm, gas and plumbing. Contractor shall mark the as-builts to show the actual installation where the installation varies from the Work as originally shown. Contractor shall mark whichever drawings are most capable of showing conditions fully and where shop drawings are used, Contractor must record a cross-reference at the corresponding location on the contract drawings. Contractor shall give particular attention to concealed elements that would be difficult to measure and record at a later date. Contractor shall use colors to distinguish variations in separate categories of The Work.
- b. Contractor shall note related change order, request for information, request for proposals, or Architect’s Supplemental Instructions where applicable. Contractor shall organize as-builts into manageable sets, bound with durable paper cover sheets and shall print suitable title, dates and other identification on the cover of each set. Contractor to also provide an electronic version of the as-builts in .pdf or other approved format. The suitability of the as-builts will be determined by the Engineer.

ARTICLE 50. RESOLUTION OF CONSTRUCTION CLAIMS

- a. All public works claims between the Contractor and the City shall be resolved pursuant to the procedures set forth in Public Contract Code section 9204. All public works claims of \$375,000 or less which arise between the Contractor and City shall be resolved in accordance with Public Contract Code sections 20104 et seq. and other applicable law, unless the City has elected to resolve the dispute pursuant to Public Contract Code Section 10240 et seq.
- b. Contractor shall timely comply with all notices and requests for additional compensation and extensions of time, including but not limited to all requirements of Article 45, as a prerequisite to filing any claim governed by this Article. The failure to timely provide any notice or request required by the Contract Documents shall constitute a waiver of the right to these procedures.

SECTION 00700
GENERAL CONDITIONS

- c. All Claims. All claims shall be submitted in writing and accompanied by substantiating documentation. Claims must be filed on or before the date of final payment unless other notice requirements are provided in the contract. "Claim" means a separate demand by the Contractor for (1) a time extension, including without limitation relief from damages or penalties for delay assessed by the City, (2) payment of money or damages arising from work done by or on behalf of the Contractor and payment of which is not otherwise expressly provided for or the Contractor is not otherwise entitled, or (3) payment of an amount which is disputed by City.
- d. All Claims. The Contractor will submit the claim justification in the following format:
- 1) Summary of claim merit and price, and Contract clause pursuant to which the claim is made.
 - 2) List of documents relating to claim
 - (a) Specifications
 - (b) Drawings
 - (c) Clarifications (Requests for Information)
 - (d) Schedules
 - (e) Other
 - 3) Chronology of events and correspondence
 - 4) Analysis of claim merit
 - 5) Analysis of claim cost
 - 6) Analysis of time impact analysis in CPM format
 - 7) Cover letter and certification of validity of the claim
- e. City Response to Claim. Upon receipt of a Claim pursuant to this Article, the City shall conduct a reasonable review of the Claim and, within a period not to exceed 45 days of receipt of the claim, or as extended by mutual agreement, shall provide a written statement identifying what portion of the Claim is disputed and what portion is undisputed. Any payment due on an undisputed portion of the Claim will be processed and made within 60 days after the City issues its written response.

If the City needs approval from the City Council to provide Contractor a written statement as set forth above, and the City Council does not meet within the 45 days or within the mutually agreed to extension of time following receipt of a Claim, the City shall have up to three (3) days following the next publicly noticed City Council meeting after the 45-day period, or extension, expires to provide

SECTION 00700
GENERAL CONDITIONS

Contractor a written statement identifying the disputed portion and the undisputed portion of the Claim.

The City may request, in writing, within 30 days of receipt of the claim, any additional documentation supporting the claim or relating to defenses or claims the City may have. If additional information is needed thereafter, it shall be provided upon mutual agreement of the City and the claimant. The City's written response shall be submitted 30 days (15 days if the Claim is less than \$50,000) after receiving the additional documentation, or within the same period of time taken by the claimant to produce the additional information, whichever is greater.

- f. Meet and Confer Conference. If the Contractor disputes City's response, or if City fails to respond within the statutory time period(s), the Contractor may so notify City within 15 days of the receipt of the response or the failure to respond, and demand an informal conference to meet and confer for settlement of those portions of the Claim that remain in dispute. Upon such demand, City shall schedule a meet and confer conference within 30 days.
- g. Mediation. Within 10 business days following the conclusion of the meet and confer conference, if the claim or any portion thereof remains in dispute, the City shall provide the Contractor with a written statement identifying the portion of the claim that remains in dispute and the portion that is undisputed. Any portion of the claim that remains in dispute shall be submitted to nonbinding mediation. The selection of the mediator shall be in accordance with Public Contract Code section 9204, and the City and the Contractor shall equally share the associated mediator fees. Each party will be responsible for its own attorneys' fees and other costs incurred due to the resolution of any Claim.
- h. Condition Precedent. Submission of a claim, properly certified, with all required supporting documentation, and written rejection or denial of all or part of the claim by City, is a condition precedent to any action, proceeding, litigation, suit, general conditions claim, or demand for arbitration by Contractor.
- i. Government Code Claim. In addition to any and all contract requirements pertaining to notices of and requests for compensation or payment for extra work, disputed work, construction claims and/or changed conditions, the Contractor must comply with the claim procedures set forth in Government Code section 900 et seq. prior to filing any lawsuit against the City. Such Government Code claims and any subsequent lawsuit based upon the Government Code claims shall be limited to those matters that remain unresolved after all procedures pertaining to extra work, disputed work, construction claims, and/or changed conditions have been followed by Contractor. If no such Government Code claim is submitted, or if the prerequisite contractual requirements are not otherwise satisfied as specified herein, Contractor shall be barred from bringing and maintaining a valid lawsuit against the City.

ARTICLE 51. CITY'S RIGHT TO TERMINATE CONTRACT

- a. Termination for Cause. City may, without prejudice to any other right or remedy, serve written notice upon Contractor of its intention to terminate this Contract in

SECTION 00700
GENERAL CONDITIONS

whole or in part if the Contractor: (i) refuses or fails to prosecute The Work or any part thereof with such diligence as will ensure its completion within the time required; (ii) fails to complete The Work within the required time; (iii) should file a bankruptcy petition or be adjudged a bankrupt; (iv) should make a general assignment for the benefit of its creditors; (v) should have a receiver appointed; (vi) should persistently or repeatedly refuse or fail to supply enough properly skilled workers or proper materials to complete the work; (vii) should fail to make prompt payment to subcontractors or for material or labor; (viii) persistently disregard laws, ordinances, other requirements or instructions of City; or (ix) should violate any of the provisions of the Contract Documents.

The notice of intent to terminate shall contain the reasons for such intention to terminate. Unless within ten (10) Days after the service of such notice, such condition shall cease or satisfactory arrangements (acceptable to City) for the required correction are made, this Contract shall be terminated. In such case, Contractor shall not be entitled to receive any further payment until the Project has been finished. City may take over and complete The Work by any method it may deem appropriate. Contractor and its surety shall be liable to City for any excess costs or other damages incurred by City to complete the Project. If City takes over The Work, City may, without liability for so doing, take possession of and utilize in completing The Work such materials, appliances, plant, and other property belonging to the Contractor as may be on the Project site.

- b. Termination For Convenience. City may terminate performance of The Work in whole or, in part, if City determines that a termination is in City's interest.

The Contractor shall terminate all or any part of The Work upon delivery to the Contractor of a Notice of Termination specifying that the termination is for the convenience of City, the extent of termination, and the effective date of such termination.

After receipt of Notice of Termination, and except as directed by City, the Contractor shall, regardless of any delay in determining or adjusting any amounts due under this Termination for Convenience clause, immediately proceed with the following obligations:

- 1) Stop Work as specified in the Notice.
- 2) Complete any Work specified in the Notice of Termination in a least cost/shortest time manner while still maintaining the quality called for under the Contract Documents.
- 3) Leave the property upon which the Contractor was working and upon which the facility (or facilities) forming the basis of the Contract Documents is situated in a safe and sanitary manner such that it does not pose any threat to the public health or safety.
- 4) Terminate all subcontracts to the extent that they relate to the portions of The Work terminated.
- 5) Place no further subcontracts or orders, except as necessary to complete the remaining portion of The Work.

SECTION 00700
GENERAL CONDITIONS

- 6) Submit to City, within ten (10) Days from the effective date of the Notice of Termination, all of the documentation called for by the Contract Documents to substantiate all costs incurred by the Contractor for labor, materials and equipment through the Effective Date of the Notice of Termination. Any documentation substantiating costs incurred by the Contractor solely as a result of City's exercise of its right to terminate this Contract pursuant to this clause, which costs the Contractor is authorized under the Contract Documents to incur, shall: (i) be submitted to and received by City no later than thirty (30) Days after the Effective Date of the Notice of Termination; (ii) describe the costs incurred with particularity; and (iii) be conspicuously identified as "Termination Costs Occasioned by City's Termination for Convenience."
 - 7) These provisions are in addition to and not in limitation of any other rights or remedies available to City.
- c. Savings Clause. If City terminates Contractor for cause, and if it is later determined that the termination was wrongful, such default termination shall automatically be converted to and treated as a termination for convenience. In such event, Contractor shall be entitled to receive only the amounts payable under this section, and Contractor specifically waives any claim for any other amounts or damages, including, but not limited to, any claim for consequential damages or lost profits.
 - d. Exception. Notwithstanding any other provision of this Article, when immediate action is necessary to protect life and safety or to reduce significant exposure or liability, City may immediately order Contractor to cease Work on the Project until such safety or liability issues are addressed to the satisfaction of City or the Contract is terminated.

ARTICLE 52. WARRANTY AND GUARANTEE

- a. Contractor warrants that all materials and equipment furnished under this Contract shall be new unless otherwise specified in the Contract Documents; and that all Work conforms to the Contract Document requirements and is free of any defect whether performed by the Contractor or any subcontractor or supplier.
- b. Unless otherwise stated, all warranty periods shall begin upon the filing of the Notice of Completion. Unless otherwise stated, the warranty period shall be for one year.
- c. The Contractor shall remedy at its expense any damage to City-owned or controlled real or personal property.
- d. City shall notify the Contractor, in writing, within a reasonable time after the discovery of any failure, defect, or damage. The Contractor shall within ten (10) Days after being notified commence and perform with due diligence all necessary Work. If the Contractor fails to promptly remedy any defect, or damage; the City have the right to replace, repair, or otherwise remedy the defect, or damage at the Contractor's expense.

SECTION 00700
GENERAL CONDITIONS

- e. In the event of any emergency constituting an immediate hazard to health, safety, property, or licensees, when caused by Work of the Contractor not in accordance with the Contract requirements, City may undertake at Contractor's expense, and without prior notice, all Work necessary to correct such condition.
- f. With respect to all warranties, express or implied, from subcontractors, manufacturers, or suppliers for Work performed and Materials furnished under this Contract, the Contractor shall:
 - 1) Obtain for City all warranties that would be given in normal commercial practice;
 - 2) Require all warranties to be executed, in writing, for the benefit of City; and
 - 3) Enforce all warranties for the benefit of City, unless otherwise directed in writing by City.

This Article shall not limit City's rights under this Contract or with respect to latent defects, gross mistakes, or fraud. City specifically reserves all rights related to defective work, including but not limited to the defect claims pursuant to California Code of Civil Procedure Section 337.15.

ARTICLE 53. DOCUMENT RETENTION & EXAMINATION

- a. In accordance with Government Code Section 8546.7, records of both City and the Contractor shall be subject to examination and audit by the State Auditor General for a period of three (3) years after final payment.
- b. Contractor shall make available to City any of the Contractor's other documents related to the Project immediately upon request of City.
- c. In addition to the State Auditor rights above, City shall have the right to examine and audit all books, estimates, records, contracts, documents, bid documents, subcontracts, and other data of the Contractor (including computations and projections) related to negotiating, pricing, or performing the modification in order to evaluate the accuracy and completeness of the cost or pricing data at no additional cost to City, for a period of four (4) years after final payment.

ARTICLE 54. SOILS INVESTIGATIONS

When a soils investigation report for the Project site is available, as otherwise noted, such report shall not be a part of the Contract Documents. Any information obtained from such report as to subsurface soil condition, or to elevations of existing grades or elevations of underlying rock, is approximate only and is not guaranteed. Contractor acknowledges that any soils investigation report (including any borings) was prepared for purposes of design only and Contractor is required to examine the site before submitting its bid and must make whatever tests it deems appropriate to determine the underground condition of the soil.

ARTICLE 55. SEPARATE CONTRACTS

- a. City reserves the right to let other contracts in connection with this Work or on the Project site. Contractor shall permit other contractors reasonable access and storage of their materials and execution of their work and shall properly connect and coordinate its Work with theirs.
- b. To ensure proper execution of its subsequent Work, Contractor shall immediately inspect work already in place and shall at once report to the Engineer any problems with the work in place or discrepancies with the Contract Documents.
- c. Contractor shall ascertain to its own satisfaction the scope of the Project and nature of any other contracts that have been or may be awarded by City in prosecution of the Project to the end that Contractor may perform this Contract in the light of such other contracts, if any. Nothing herein contained shall be interpreted as granting to Contractor exclusive occupancy at site of the Project. Contractor shall not cause any unnecessary hindrance or delay to any other contractor working on the Project. If simultaneous execution of any contract for the Project is likely to cause interference with performance of some other contract or contracts, the Engineer shall decide which Contractor shall cease Work temporarily and which contractor shall continue or whether work can be coordinated so that contractors may proceed simultaneously. City shall not be responsible for any damages suffered or for extra costs incurred by Contractor resulting directly or indirectly from award, performance, or attempted performance of any other contract or contracts on the Project site.

ARTICLE 56. NOTICE AND SERVICE THEREOF

All notices shall be in writing and either served by personal delivery or mailed to the other party as designated in the Bid Forms. Written notice to the Contractor shall be addressed to Contractor's principal place of business unless Contractor designates another address in writing for service of notice. Notice to City shall be addressed to City as designated in the Notice Inviting Bids unless City designates another address in writing for service of notice. Notice shall be effective upon receipt or five (5) Days after being sent by first class mail, whichever is earlier. Notice given by facsimile shall not be effective unless acknowledged in writing by the receiving party.

ARTICLE 57. NOTICE OF THIRD PARTY CLAIMS

Pursuant to Public Contract Code Section 9201, City shall provide Contractor with timely notification of the receipt of any third-party claim relating to the Contract.

ARTICLE 58. STATE LICENSE BOARD NOTICE

Contractors are required by law to be licensed and regulated by the Contractors' State License Board which has jurisdiction to investigate complaints against contractors if a complaint regarding a patent act or omission is filed within four (4) years of the date of the alleged violation. A complaint regarding a latent act or omission pertaining to structural defects must be filed within ten (10) years of the date of the alleged violation. Any questions concerning a contractor may be

SECTION 00700
GENERAL CONDITIONS

referred to the Registrar, Contractors' State License Board, P.O. Box 26000, Sacramento, California 95826.

ARTICLE 59. INTEGRATION

- a. Oral Modifications Ineffective. No oral order, objection, direction, claim or notice by any party or person shall affect or modify any of the terms or obligations contained in the Contract Documents.
- b. Contract Documents Represent Entire Contract. The Contract Documents represent the entire agreement of City and Contractor.

ARTICLE 60. ASSIGNMENT

Contractor shall not assign, transfer, convey, sublet, or otherwise dispose of this Contract or any part thereof including any claims, without prior written consent of City. Any assignment without the written consent of City shall be void. Any assignment of money due or to become due under this Contract shall be subject to a prior lien for services rendered or Material supplied for performance of Work called for under the Contract Documents in favor of all persons, firms, or corporations rendering such services or supplying such Materials to the extent that claims are filed pursuant to the Civil Code, the Code of Civil Procedure or the Government Code.

ARTICLE 61. CHANGE IN NAME AND NATURE OF CONTRACTOR'S LEGAL ENTITY

Should a change be contemplated in the name or nature of the Contractor's legal entity, the Contractor shall first notify City in order that proper steps may be taken to have the change reflected on the Contract.

ARTICLE 62. ASSIGNMENT OF ANTITRUST ACTIONS

Pursuant to Section 7103.5 of the Public Contract Code, in entering into a public works contract or subcontract to supply goods, services, or materials pursuant to a public works contract, Contractor or subcontractor offers and agrees to assign to City all rights, title, and interest in and to all causes of action it may have under Section 4 of the Clayton Act (15 U.S.C. Section 15) or under the Cartwright Act (chapter 2 (commencing with Section 16700) of part 2 of division 7 of the Business and Professions Code), arising from the purchase of goods, services, or materials pursuant to this Contract or any subcontract. This assignment shall be made and become effective at the time City makes final payment to the Contractor, without further acknowledgment by the parties.

ARTICLE 63. PROHIBITED INTERESTS

No City official or representative who is authorized in such capacity and on behalf of City to negotiate, supervise, make, accept, or approve, or to take part in negotiating, supervising, making, accepting or approving any engineering, inspection, construction or material supply contract or any subcontract in connection with construction of the project, shall be or become directly or indirectly interested financially in the Contract.

SECTION 00700
GENERAL CONDITIONS

ARTICLE 64. LAWS AND REGULATIONS

- a. Contractor shall give all notices and comply with all federal, state and local laws, ordinances, rules and regulations bearing on conduct of work as indicated and specified by their terms. References to specific laws, rules or regulations in this Contract are for reference purposes only, and shall not limit or affect the applicability of provisions not specifically mentioned. If Contractor observes that drawings and specifications are at variance therewith, he shall promptly notify the Engineer in writing and any necessary changes shall be adjusted as provided for in this Contract for changes in work. If Contractor performs any work knowing it to be contrary to such laws, ordinances, rules and regulations, and without such notice to the Engineer, he shall bear all costs arising therefrom.
- b. Contractor shall be responsible for familiarity with the Americans with Disabilities Act ("ADA") (42 U.S.C. § 12101 et seq.). The Work will be performed in compliance with ADA regulations.

ARTICLE 65. PATENT FEES OR ROYALTIES

The Contractor shall include in its bid amount the patent fees or royalties on any patented article or process furnished or used in the Work. Contractor shall assume all liability and responsibility arising from the use of any patented, or allegedly patented, materials, equipment, devices or processes used in or incorporated with The Work, and shall defend, indemnify and hold harmless City, its officials, officers, agents, employees and representatives from and against any and all liabilities, demands, claims, damages, losses, costs and expenses, of whatsoever kind or nature, arising from such use.

ARTICLE 66. OWNERSHIP OF DRAWING

All Contract Documents furnished by City are City property. They are not to be used by Contractor or any subcontractor on other work nor shall Contractor claim any right to such documents. With exception of one complete set of Contract Documents, all documents shall be returned to City on request at completion of The Work.

ARTICLE 67. NOTICE OF TAXABLE POSSESSORY INTEREST

In accordance with Revenue and Taxation Code Section 107.6, the Contract Documents may create a possessory interest subject to personal property taxation for which Contractor will be responsible.

END OF GENERAL CONDITIONS

**SECTION 00750
SPECIAL CONDITIONS**

1. SPECIFIC MATERIALS

See Project Plans and Specifications.

2. PROJECT RETENTION; SUBSTANTIAL COMPLEXITY

Not Applicable.

3. STORM WATER SPECIFICATIONS

Erosion and sediment control devices will require modification and ongoing maintenance as the Work progresses to achieve the goals of the Erosion Control Plan and the Storm Water Pollution Prevention Plan (SWPPP) or National Pollution Discharge Elimination System (NPDES) when a SWPPP is not required for the project. Placement of additional devices may be necessary to achieve those goals at various stages of the Work.

Contractor shall inspect and maintain all BMP's on a daily basis. Gutters and streets shall be cleaned daily. Broken sand/gravel bags and other erosion/sediment control devices shall be replaced immediately. Additionally, the Engineer may require a daily log by the Contractor indicating who performed the BMP inspection and what maintenance was performed.

Failure of the Contractor to comply with an Engineer's correction notice may result in an order to suspend work until the condition is corrected. No additional compensation, time nor payment, will be allowed as a result of such a suspension.

Any fines levied by the State Water Resources Control Board, City, or other entity having authority to do so, as a result of the Work not complying with the S.W.P.P.P. (or NPDES if no SWPPP) shall become the responsibility of the Contractor. The amount of the fine may be deducted from monies due the Contractor, at the discretion of the Engineer, until the fine is paid or otherwise resolved.

4. PRE-CONSTRUCTION MEETING.

After, or upon, notification of Contract Award, the Engineer will set the time and location for the Pre-Construction Meeting. Attendance of the Contractor's management personnel responsible for the management, administration, and execution of the project is mandatory for the meeting to be convened. Failure of the Contractor to have the Contractor's responsible project personnel attend the Pre-Construction Meeting will be grounds for default by Contractor. No separate payment will be made for the Contractor's attendance at the meeting. The Notice to Proceed will only be issued on or after the completion of the Pre-Construction meeting.

5. MODIFICATION OF HOURS OF WORK

The Contractor's activities shall be confined to Monday through Friday, excluding City holidays and weekends. The Contractor's activities shall be confined to the hours between 8:00 a.m. and

SECTION 00750
SPECIAL CONDITIONS

4:30 p.m. Working hours on arterial streets, including closure of travel lanes, will be allowed only between the hours of 9:00 a.m. and 3:00 p.m. Deviation from these hours will not be permitted without written request and the prior consent of the Engineer, except in emergencies involving immediate hazard to persons or property. In the event of either a requested, or emergency deviation, inspection service fees will be charged against the Contractor. The service fees will be calculated at overtime rates, including benefits, overhead, and travel time. The service fees will be deducted from any amounts due the Contractor.

6. STREET CLOSURES, DETOURS, BARRICADES

Existing electrical systems (traffic signal, highway and street lighting, flashing beacon, sign illumination and other facilities), or approved temporary replacements thereof, shall be kept in effective operation for the benefit of the traveling public during the progress of the work, except when shutdown is permitted to allow for alterations or final removal of the systems. The traffic signal shutdowns shall be limited to normal working hours, or shall be as specified in the special provisions. Lighting system shutdowns shall not interfere with the regular lighting schedule, unless otherwise permitted by the Engineer. The Contractor shall notify the Engineer prior to performing any work on existing systems.

The Contractor shall notify the City prior to any operational shutdown of a traffic signal. The City will:

1. Continue the operation and maintenance of existing electrical facilities.
2. Continue to provide for electrical energy for the operation of existing electrical facilities.
3. Repair or replace existing facilities damaged by public traffic.
4. Pay the cost of electrical energy for the operation of existing or new facilities that are undergoing the functional tests.

The Contractor shall ascertain the exact location and depth of existing detectors, conduits, pull boxes and other electrical facilities before using any tools or equipment that may damage those facilities or interfere with any electrical system.

Where damage is caused by the Contractor's operations, the Contractor shall, at the Contractor's expense, repair or replace damaged facilities promptly in conformance with these specifications. If any existing loop conductor, including the portion leading to the detector handhole or termination pull box, is damaged by the contractor's operations, the Contractor shall immediately notify the Engineer. The affected detectors shall be replaced at the Contractor's expense and as directed by the Engineer within 24 hours. If the Contractor fails to complete the repairs within this period, the repairs will be made by the City at the Contractor's expense.

Should the Contractor fail to perform the required repairs or replacements, the cost of performing the repairs or replacements will be deducted from any moneys due or to become due to the Contractor.

SECTION 00750
SPECIAL CONDITIONS

Where roadways are to remain open to traffic and existing lighting systems are to be modified, the lighting systems shall remain in operation and the final connection to the modified circuit shall be made so that the modified circuit will be in operation by nightfall of the same day.

Temporary electrical installations shall be kept in effective operation until the temporary installations are no longer required for the traveling public.

During traffic signal system shutdown the Contractor shall place "STOP AHEAD" and "STOP" signs to direct vehicle and pedestrian traffic through the intersection. All signal faces shall be covered when the system is shutdown overnight. Temporary "STOP AHEAD" and "STOP" signs shall be either covered or removed when the system is turned on.

"STOP AHEAD" and "STOP" signs shall be furnished by the Contractor and shall conform to the provisions in Caltrans Standard Specification section 12-3.06, "Construction Area Signs." Minimum size of "STOP" signs shall be 30 inches.

One "STOP AHEAD" sign and one "STOP" sign shall be placed for each direction of traffic. For two-lane approaches, 2 "STOP" signs shall be placed. Location of the signs shall be as directed by the Engineer.

Barricades shall be equipped with flashing warning lights. All power required devices shall be operated by batteries, rather than generators.

Street closures will not be allowed, except as specifically permitted by the Engineer. Traffic control shall be approved by the Engineer.

Lane transitions shall conform to the latest edition of the California Manual on Uniform Traffic Control Devices (MUTCD).

Temporary traffic channelization shall be accomplished with barricades or delineators. Temporary striping will not be allowed unless specifically permitted by the Engineer. The Contractor shall prepare any plans that may be required for temporary striping to the satisfaction of the Engineer. In no event will temporary striping be allowed on finished pavement surfaces, which are to remain. The Contractor shall prepare any traffic control or detour plans that may be required as directed by the Engineer. The Contractor shall submit Traffic Control Plans for all work on arterial roads, prepared and signed by a California Registered Civil or Traffic Engineer at least ten (10) working days prior to commencing work.

The Contractor shall schedule an employee to police the temporary delineators and barricades within the travel way during weekday, nonworking hours, and over Saturdays, Sundays, and holidays. Any corrective work required to be done by City forces shall be back charged to the Contractor based on the actual costs, plus City overhead and withheld from the final payment.

All costs to the Contractor for street closures, detours, barricades, and associated plans shall be included in various lump sum contract bid items, and no separate payment will be made therefore.

7. SURVEY CONTROL AND REFERENCE POINTS

SECTION 00750
SPECIAL CONDITIONS

Prior to the start of construction, the Contractor (its licensed surveyor or qualified engineer) shall locate all monuments (both of record and not of record), bench marks, and centerline ties within one hundred feet of the construction activity. Additional ties to monuments shall be set when ties are missing (min. four ties per monument). The Contractor shall prepare and submit for review to the City Engineer separate tie sheets and Corner Record sheets (monuments not of record shall have only tie sheets prepared). Corner Records shall conform to the County Engineers' Association of California's "Guide to the Preparation of Records of Survey and Corner Records" document as provided by the County of Orange Land Surveyor's Office and on file in the City of San Clemente City Engineers Office. Upon review by the City Engineer, the Contractor shall file the Corner Records with the County of Orange Land Surveyor's Office. Certified Corner Records shall be filed with the City Engineer. Prior to final Acceptance by the City, the Contractor shall re-survey all field monuments and centerline ties within the construction zone, prepare tie sheets and corner record sheets as indicated above, and file them with the City Engineer for review. After review by the City Engineer, the land surveyor shall file the corner records with the County Land Surveyors Office, and file certified copies of the corner records with the City Engineer.

All survey monuments removed or altered as a result of construction shall be reset, corner records shall be filed with the County of Orange Land Surveyor's Office, and approved final corner records shall be filed with the City Engineer. Centerline ties removed as a result of construction shall be reset and tie sheets filed with the City Engineer.

Contractor shall provide a letter of certification for all monuments having four or more existing ties which are within 0.02 ft plus or minus of the original City tie sheet records. When several monuments and ties appear on one tie sheet and one of the ties has changed the land surveyor shall re-measure all of the ties and re-file a new ties sheet with the City as required herein.

County of Orange permanent and temporary bench marks within the construction zone shall be located by survey, and the Contractor shall send a written notification of impending construction to the County of Orange Land Surveyor's Office two weeks prior to construction.

END OF SPECIAL CONDITIONS

SECTION 00800
TECHNICAL SPECIFICATIONS

SEE PROJECT PLANS FOR TECHNICAL SPECIFICATIONS

END OF TECHNICAL SPECIFICATIONS

**APPENDIX 1
INSURANCE REQUIREMENTS**

1. WORKERS' COMPENSATION AND EMPLOYER'S LIABILITY INSURANCE

Contractor shall maintain Workers' Compensation Insurance (Statutory Limits) and Employer's Liability Insurance (with limits of at least \$1,000,000) for Contractor's employees in accordance with the laws of the State of California, Section 3700 of the Labor Code. In addition, Contractor shall require each subcontractor to similarly maintain Workers' Compensation Insurance and Employer's Liability Insurance in accordance with the laws of the State of California, Section 3700 for all of the subcontractor's employees.

Contractor shall submit to City, along with the certificate of insurance, a Waiver of Subrogation endorsement in favor of City, its officials, officers, employees, agents, and volunteers. Company or companies providing insurance coverage shall be acceptable to City, if in the form and coverage as set forth in the Contract Documents.

2. COMMERCIAL GENERAL LIABILITY INSURANCE

- a. Contractor shall procure and maintain during the life of this Contract and for such other period as may be required herein, at its sole expense, occurrence form Commercial General Liability insurance coverage, at least as broad as the most current ISO CGL Form 00 01 including but not limited to, premises liability, contractual liability, products/completed operations if applicable, personal and advertising injury which may arise from or out of Contractor's operations, use, and management of the Project site, or the performance of its obligations hereunder. Policy limits shall not be less than \$1,000,000 per occurrence, \$2,000,000 general aggregate, for bodily injury, personal injury and property damage, including without limitation, blanket contractual liability, and a \$2,000,000 completed operations aggregate. Defense costs shall be paid in addition to the limits.
- b. Such policy shall comply with all the requirements of this Article. The limits set forth herein shall apply separately to each insured against whom claims are made or suits are brought, except with respect to the limits of liability. Further the limits set forth herein shall not be construed to relieve the Contractor from liability in excess of such coverage, nor shall it limit Contractor's indemnification obligations to City, and shall not preclude City from taking such other actions available to City under other provisions of the Contract Documents or law.
- c. Contractor shall make certain that any and all subcontractors hired by Contractor are insured in accordance with this Contract. If any subcontractor's coverage does not comply with the foregoing provisions, Contractor shall indemnify and hold City harmless from any damage, loss, cost, or expense, including attorneys' fees, incurred by City as a result thereof.
- d. All general liability policies provided pursuant to the provisions of this Article shall comply with the provisions of the Contract Documents.

APPENDIX 1
INSURANCE REQUIREMENTS

- e. All general liability policies shall be written to apply to all bodily injury, including death, property damage, personal injury, owned and non-owned equipment, blanket contractual liability, completed operations liability, explosion, collapse, under-ground excavation, removal of lateral support, and other covered loss, however occasioned, occurring during the policy term, and shall specifically insure the performance by Contractor of that part of the indemnification contained in these General Conditions, relating to liability for injury to or death of persons and damage to property. If the coverage contains one or more aggregate limits, a minimum of 50% of any such aggregate limit must remain available at all times; if over 50% of any aggregate limit has been paid or reserved, City may require additional coverage to be purchased by Contractor to restore the required limits. Any umbrella policy shall “follow form” to the underlying primary policies.

3. AUTOMOBILE LIABILITY INSURANCE

Contractor shall take out and maintain at all times during the term of this Contract Automobile Liability Insurance at least as broad as ISO CA 00 01 (Any Auto) covering bodily injury and property damage for all activities of the Contractor arising out of or in connection with Work to be performed under these Contract Documents, including coverage for any owned, hired, non-owned or rented vehicles, in an amount not less than \$1,000,000 combined single limit for each accident. Such insurance shall be provided in a form and with insurance companies acceptable to City and comply with the provisions of Section 7 below.

4. CONTRACTORS POLLUTION LIABILITY

Not Applicable.

5. UMBRELLA INSURANCE.

Contractor shall obtain and maintain an umbrella insurance policy with limits of not less than \$4,000,000 that will provide bodily injury, personal injury and property damage liability coverage at least as broad as the primary coverages set forth above, including commercial general liability and automobile liability. Such policy or policies shall include the following terms and conditions:

- a. A drop down feature requiring the policy to respond in the event that any primary insurance that would otherwise have applied proves to be uncollectable in whole or in part for any reason;
- b. Pay on behalf of wording as opposed to reimbursement;
- c. Concurrency of effective dates with primary policies; and
- d. Policies shall “follow form” to the underlying primary policies.
- e. Insureds under primary policies shall also be insureds under the umbrella or excess policies.

6. BUILDER’S RISK [“ALL RISK”]

Not Applicable.

7. FORM AND PROOF OF CARRIAGE OF INSURANCE

- a. Any insurance carrier providing insurance coverage required by the Contract Documents shall be authorized to do business in the State of California unless waived, in writing, by City's Risk Manager. Carrier(s) shall have an A.M. Best rating of not less than an A-VII.
- b. Insurance deductibles or self-insured retentions greater than \$5,000 must be declared by the Contractor, and such deductibles and retentions shall have the prior written consent from City. At the election of City the Contractor shall either 1) reduce or eliminate such deductibles or self-insured retentions, or 2) procure a bond which guarantees payment of losses and related investigations, claims administration, and defense costs and expenses.
- c. Contractor shall cause its insurance carrier(s) to furnish City with either 1) a properly executed original Certificate(s) of Insurance and certified original copies of Endorsements effecting coverage as required herein, or 2) if requested to do so in writing by City's Risk Manager, provide original Certified copies of policies including all Endorsements and all attachments thereto, showing such insurance is in full force and effect. All required policies of Commercial General Liability insurance shall be endorsed to name the City, its officials, officers, employees, agents and volunteers as additional insureds. For all policies of Commercial General Liability insurance, Contractor shall provide endorsements in the form of ISO CG 20 10 10 01 and 20 37 01 01 (or endorsements providing the exact same coverage) to effectuate this requirement. Further, all policies of insurance shall contain or shall be endorsed to contain the covenant of the insurance carrier(s) that shall provide no less than thirty (30) days written notice be given to City prior to any material modification or cancellation of such insurance.
- d. In the event of a material modification or cancellation of coverage, City may terminate or Stop Work pursuant to the Contract Documents, unless City receives, prior to such effective date, another properly executed original Certificate of Insurance and original copies of endorsements or certified original policies, including all endorsements and attachments thereto evidencing coverages set forth herein and the insurance required herein is in full force and effect. Contractor shall not take possession, or use the Project site, or commence operations under these Contract Documents until City has been furnished original Certificate(s) of Insurance and certified original copies of Endorsements or policies of insurance including all Endorsements and any and all other attachments as required in this Section. The original Endorsements for each policy and the Certificate of Insurance shall be signed by an individual authorized by the insurance carrier to do so on its behalf.
- e. All required insurance coverages shall contain or be endorsed to waive subrogation against the City, its officials, officers, employees, agents, and volunteers or shall specifically allow Contractor or others providing insurance evidence in compliance with these specifications to waive their right of recovery prior to a loss. Contractor hereby waives its own right of recovery against City, and shall require similar written express waivers and insurance clauses from each of its Subcontractors. Contractor shall indemnify and hold City harmless from any

APPENDIX 1
INSURANCE REQUIREMENTS

damage, loss, cost, or expense, including attorneys' fees, incurred by City from Contractor's failure to ensure its Subcontractors waive right of recovery against City.

- f. It is understood and agreed to by the parties hereto and the insurance company(s), that the Certificate(s) of Insurance and policies shall so covenant and shall be construed as primary, and City's insurance and/or deductibles and/or self-insured retentions or self-insured programs shall not be construed as contributory. The Contractor shall provide endorsement(s) to this effect at the City's request.
- g. City reserves the right to adjust the monetary limits of insurance coverage's during the term of this Contract including any extension thereof-if in City's reasonable judgment, the amount or type of insurance carried by the Contractor becomes inadequate.
- h. In the event any policy of insurance required by the Contract Documents does not comply with these specifications or is canceled and not replaced immediately so as to avoid a lapse in the required coverage, City has the right but not the duty to obtain the insurance it deems necessary and any premium paid by City will be promptly reimbursed by Contractor or City will withhold amounts sufficient to pay premium from Contractor payments. In the alternative, City may cancel this Contract, effective upon notice.
- i. Contractor acknowledges and agrees that actual or alleged failure on the part of the City to inform Contractor of non-compliance with any requirement imposed no additional obligation on the City nor does it waive any rights hereunder.
- j. **Requirements not limiting.** Requirements of specific coverage or limits are not intended as a limitation on coverage, limits or other requirements, or a waiver of any coverage normally provided by any insurance. Specific reference to a given coverage feature is for purposes of clarification only as it pertains to a given issue and is not intended by any party or insured to be all inclusive, or to the exclusion of other coverage, or a waiver of any type. If the Contractor maintains higher limits than the minimums shown above, the City requires and shall be entitled to coverage for the higher limits maintained by the Contractor. Any available insurance proceeds in excess of the specified minimum limits of insurance and coverage shall be available to the City..
- k. Contractor shall be responsible for causing all Subcontractors of any tier working under this Contract to purchase insurance meeting the requirements contained herein, including adding the City its officials, officers, employees, agents and volunteers as Additional Insureds to the subcontractor's policies. All policies of Commercial General Liability insurance provided by Subcontractors shall be endorsed to name the City, its officials, officers, employees, agents and volunteers as additional insureds using endorsement form ISO GC 20 38 04 13 (or an endorsement providing the exact same coverage) to effectuate this requirement. Contractor shall not allow any Subcontractor to commence work relating to these Contract Documents until it has received satisfactory evidence of Subcontractor's compliance with all insurance requirements under this Contract. The Contractor

APPENDIX 1
INSURANCE REQUIREMENTS

shall provide satisfactory evidence of compliance with this section upon request of the City.

**APPENDIX 2
WASTE MANAGEMENT PLAN REQUIREMENTS**

**APPENDIX 3
REDUCED SIZE CONSTRUCTION PLANS**

RESOLUTION NO. 10-11

A RESOLUTION OF THE CITY COUNCIL OF THE CITY OF SAN CLEMENTE, CALIFORNIA, ADOPTING THE NEGATIVE DECLARATION AND APPROVING THE CITY OF SAN CLEMENTE MASTER WAYFINDING SIGN PROGRAM

WHEREAS, in 2007 the City Master Wayfinding Sign Program was identified by the City Council as a Vity Few priority; and

WHEREAS, in April 2008, the City Council directed the formation of a ten (10) person Sign committee to work with staff and Graphic Solutions, the City's Sign Design Consultant to develop a City Master Wayfinding Sign Program; and

WHEREAS, the Wayfinding Sign Committee held a total of twelve (12) meetings between May 2008 and March 2009 where they reviewed and discussed the Sign Program and developed a variety of design options; and

WHEREAS, public workshops were held on June 25, 2008 and October 15, 2008. At the first workshop the public participated in a sign preference survey. The consultant Graphic Solutions used the survey and historical references to formalize initial design concepts. The Wayfinding Sign Committee then to refine the sign designs into two design choices that were presented to the public at the second worksnop in October 2008. Based upon the public feedback, the Committee developed a proposed master sign design, which could be applied to different sign types; and

WHEREAS, the Planning Division processed and completed an initial environmental assessment for this project in accordance with the California Environmental Quality Act (CEQA) and the Planning Division determined that the project would not result in any significant environmental impacts and that a Negative Declaration is warranted. The Negative Declaration was completed on October 6, 2009, 2009 and was advertised and circulated for a thirty day public review period on October 7, 2009 through November 7, 2009; and

WHEREAS, on December 9, 2008 Beaches, Parks, and Recreation Commission completed a preliminary review of the Master Wayfinding Sign Program and suggested improvements to the program and reviewed the Master Wayfinding Program again on Augsut 11, 2009 and recommended approval of the Sign Program; and

WHEREAS, on December 3, 2008, the Planning Commission completed a preliminary review of the Master Wayfinding Sign Program and suggested improvements and held a duly noticed public hearing on August 19, 2009 and recommended approval of the Sign Program; and

WHEREAS, on February 2, 2010, the City Council held a duly noticed public hearing on the subject recommendations, and considered evidence presented by City staff and other interested parties

NOW, THEREFORE, THE CITY COUNCIL OF THE CITY OF SAN CLEMENTE HEREBY RESOLVES AS FOLLOWS:

SECTION 1: Pursuant to CEQA Guidelines Section 15063, an initial study has been prepared for this project. After reviewing and considering the initial study, the proposed Negative Declaration and all comments received during the public review process, the Planning Division recommends that City Council finds that the Negative Declaration reflects the independent judgment and analysis of the City of San Clemente, and has determined that there is no substantial evidence that the project will have a significant impact on the environment. As a result of its review of the aforementioned documents, the City Council hereby adopts a Negative Declaration for the City of San Clemente Wayfinding Sign Program and authorizes issuance of a Notice of Determination pursuant to CEQA making up the record of proceedings for the Negative Declaration. Those records are retained in the Planning Department of the City of San Clemente, which is the custodian of record for those documents.

SECTION 2: The City Council hereby approves the City of San Clemente Master Wayfinding Sign Program.

PASSED AND ADOPTED this 16th day of February, 2010.

ATTEST:



City Clerk of the City of
San Clemente, California

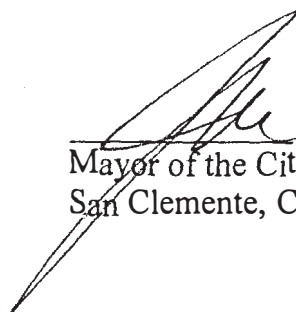

Mayor of the City of
San Clemente, California

STATE OF CALIFORNIA)
COUNTY OF ORANGE) §
CITY OF SAN CLEMENTE)

I, JOANNE BAADE, City Clerk of the City of San Clemente, California, do hereby certify that Resolution No. 10-11 was adopted at a regular meeting of the City Council of the City of San Clemente held on the 16th day of February 2010, by the following vote:

AYES: ANDERSON, BAKER, DONCHAK, EGGLESTON, MAYOR DAHL

NOES: NONE

ABSENT: NONE

IN WITNESS WHEREOF, I have hereunto set my hand and affixed the official seal of the City of San Clemente, California, this 16th day of FEB., 2010.

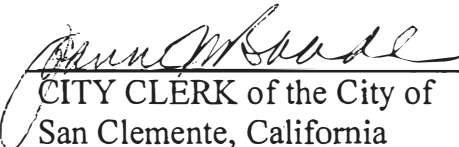
CITY CLERK of the City of
San Clemente, California

Approved as to form:

/s/ Jeff Oderman
City Attorney



AGENDA REPORT

SAN CLEMENTE CITY COUNCIL MEETING
Meeting Date: March 16, 2021

Attachment 4

Agenda Item

106

Approvals:

City Manager

ES

Dept. Head

106

Attorney

Finance

ML

Department: Public Works

Prepared By: Ziad Mazboudi, Deputy Public Works Director
Tom Bonigut, Public Works Director/City Engineer

Subject: *RECEIVE AND FILE PLAN DESIGN FOR PARK MONUMENT SIGN REPLACEMENTS, PROJECT NO. 29103.*

Fiscal Impact: None.

Summary: Staff recommends Council receive and file the plan design for the Park Monument Sign project since it is are consistent with the City's Wayfinding Sign Program.

Background: On February 16, 2010, the City Council adopted Resolution No. 10-11 (refer to Attachment 1) which approved the conceptual Master Wayfinding Sign Program (Sign Program). Prior to that date, the City had no uniform municipal sign program, which led to an assortment of sign shapes, colors, and messages. The goal of the Sign Program was to fix this problem through the creation of uniform signage that reflects the City's Spanish Village by the Sea character.

Park monument signs are included in the Sign Program with a general design consisting of a rectilinear form and use of materials that reflect Spanish Colonial Revival architecture. These materials include red brick, white smooth stucco, and dark metals. Attachment 2 provides an excerpt from the Sign Program to illustrate the design theme and intent.

Discussion: The Park Monument Sign Replacements Capital Improvement Program (CIP) project consists of removing and replacing existing monument signs at various City parks. The existing park signs will be replaced with a monument sign style as reflected in the Council-approved Sign Program. The consultant, Michael Baker International, prepared plans (refer to Attachment 3 for sample) based on the design criteria described in the Sign Program.

The park monument sign plans incorporate the asymmetrical wave shape with dark brown lettering as required by the Sign Program. The message description on the new park monument signs will include the phrase "San Clemente The Spanish Village by the Sea" and the park name. The remaining design and material features on these plans from the Sign Program also include the incorporation of red-like brick, a white stucco sign face, and dimensioned lettering.

Staff and its consultant have developed design and construction documents to start replacing aging park monument signs in a style consistent with the Council-approved

Sign Program. Therefore, staff intends to proceed with public bidding and construction of new park monument signs unless the City Council has any concerns with this approach. Staff recommends that the City Council receive and file this report.

Recommended

Action: STAFF RECOMMENDS THAT the City Council receive and file this report which confirms the approach for replacement of park monument signs consistent with the City Council approved Master Wayfinding Sign Program.

Attachments:

1. Resolution No. 10-11.
2. Master Wayfinding Sign Program Park Detail.
3. Park Monument Sign Example.

Notification: None.

s:\cd\engineering\secure\admin\2021\3-16-21\3-16-21-2r.docx

RESOLUTION NO. 10-11

A RESOLUTION OF THE CITY COUNCIL OF THE CITY OF SAN CLEMENTE, CALIFORNIA, ADOPTING THE NEGATIVE DECLARATION AND APPROVING THE CITY OF SAN CLEMENTE MASTER WAYFINDING SIGN PROGRAM

WHEREAS, in 2007 the City Master Wayfinding Sign Program was identified by the City Council as a Vity Few priority; and

WHEREAS, in April 2008, the City Council directed the formation of a ten (10) person Sign committee to work with staff and Graphic Solutions, the City's Sign Design Consultant to develop a City Master Wayfinding Sign Program; and

WHEREAS, the Wayfinding Sign Committee held a total of twelve (12) meetings between May 2008 and March 2009 where they reviewed and discussed the Sign Program and developed a variety of design options; and

WHEREAS, public workshops were held on June 25, 2008 and October 15, 2008. At the first workshop the public participated in a sign preference survey. The consultant Graphic Solutions used the survey and historical references to formalize initial design concepts. The Wayfinding Sign Committee then to refine the sign designs into two design choices that were presented to the public at the second worksnop in October 2008. Based upon the public feedback, the Committee developed a proposed master sign design, which could be applied to different sign types; and

WHEREAS, the Planning Division processed and completed an initial environmental assessment for this project in accordance with the California Environmental Quality Act (CEQA) and the Planning Division determined that the project would not result in any significant environmental impacts and that a Negative Declaration is warranted. The Negative Declaration was completed on October 6, 2009, 2009 and was advertised and circulated for a thirty day public review period on October 7, 2009 through November 7, 2009; and

WHEREAS; on December 9, 2008 Beaches, Parks, and Recreation Commission completed a preliminary review of the Master Wayfinding Sign Program and suggested improvements to the program and reviewed the Master Wayfinding Program again on Augsut 11, 2009 and recommended approval of the Sign Program; and

WHEREAS, on December 3, 2008, the Planning Commission completed a preliminary review of the Master Wayfinding Sign Program and suggested improvements and held a duly noticed public hearing on August 19, 2009 and recommended approval of the Sign Program; and

WHEREAS, on February 2, 2010, the City Council held a duly noticed public hearing on the subject recommendations, and considered evidence presented by City staff and other interested parties

NOW, THEREFORE, THE CITY COUNCIL OF THE CITY OF SAN CLEMENTE HEREBY RESOLVES AS FOLLOWS:

SECTION 1: Pursuant to CEQA Guidelines Section 15063, an initial study has been prepared for this project. After reviewing and considering the initial study, the proposed Negative Declaration and all comments received during the public review process, the Planning Division recommends that City Council finds that the Negative Declaration reflects the independent judgment and analysis of the City of San Clemente, and has determined that there is no substantial evidence that the project will have a significant impact on the environment. As a result of its review of the aforementioned documents, the City Council hereby adopts a Negative Declaration for the City of San Clemente Wayfinding Sign Program and authorizes issuance of a Notice of Determination pursuant to CEQA making up the record of proceedings for the Negative Declaration. Those records are retained in the Planning Department of the City of San Clemente, which is the custodian of record for those documents.

SECTION 2: The City Council hereby approves the City of San Clemente Master Wayfinding Sign Program.

PASSED AND ADOPTED this 16th day of February, 2010

ATTEST:

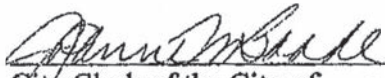

City Clerk of the City of
San Clemente, California

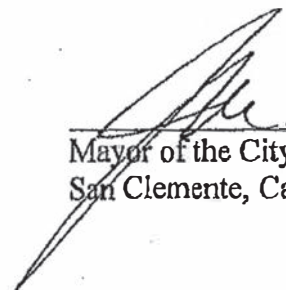

Mayor of the City of
San Clemente, California

STATE OF CALIFORNIA)
COUNTY OF ORANGE) §
CITY OF SAN CLEMENTE)

I, JOANNE BAADE, City Clerk of the City of San Clemente, California, do hereby certify that Resolution No. 10-11 was adopted at a regular meeting of the City Council of the City of San Clemente held on the 16th day of February, 2010, by the following vote:

AYES: ANDERSON, BAKER, DONCHAK, EGGLESTON, MAYOR DAHL

NOES: NONE

ABSENT: NONE

IN WITNESS WHEREOF, I have hereunto set my hand and affixed the official seal of the City of San Clemente, California, this 16th day of FEB., 2010.

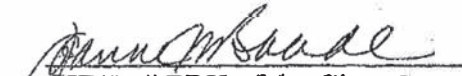
CITY CLERK of the City of
San Clemente, California

Approved as to form:

/s/ Jeff Oderman
City Attorney

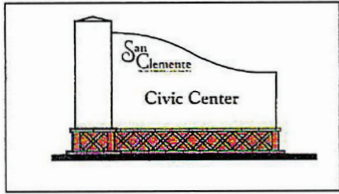

NOTE:
CIVIC - FACILITY SIGN IDENTICAL
TO CIVIC - PARK SIGN.

IDcv.2.00 IDENTITY - CIVIC - FACILITY
SCALE: 1/4" = 1'-0"

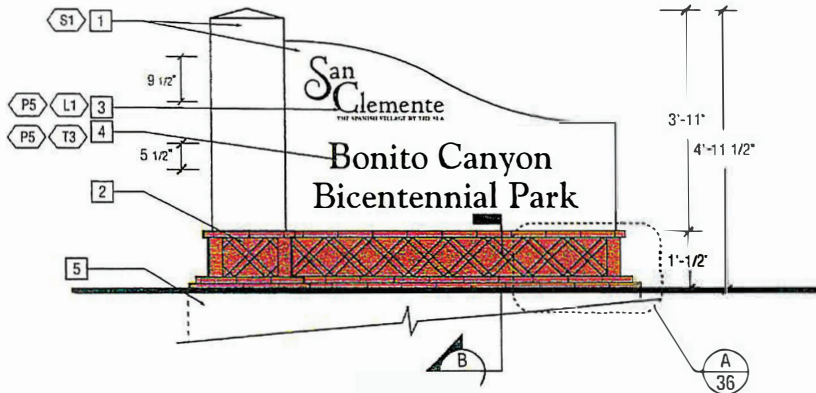
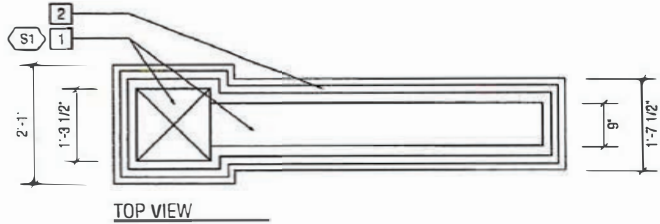

IDcv.1.00 IDENTIFICATION - CIVIC - PARK (DOUBLE FACED)
SCALE: 1/2" = 1'-0"

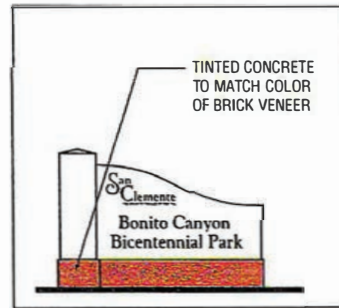

IDcv.1.00 ALTERNATE CONCRETE BASE
SCALE: 1/4" = 1'-0"

NOTE: SEE SHEET #2 AND CONSTRUCTION SPECIFICATIONS DATED 01/19/10

IDcv.1.00 SIGN SPECIFICATIONS

- 1 WALL AND COLUMN:**
SIGN CABINET FABRICATED FROM CONCRETE BOARD OVER AN INTERNAL WELDED STEEL FRAME. CABINET FINISH: WHITE STUCCO WITH A HAND TEXTURED EFFECT. ALL EDGES TO BE EASED.
- 2 SIGN BASE:**
BRICK VENEER OVER CONCRETE BASE WITH AN INTERNAL WELDED STEEL FRAME. BRICK: THOMPSONS BELDEN BELCREST 730 BLEND. WITH NATURAL GREY MORTAR.
NOTE: SIGN FABRICATOR TO SHOW BRICK PATTERN FOR MONUMENT ON SHOP DRAWINGS.
ALTERNATE BASE: TINTED CONCRETE TO MATCH BRICK COLOR.
- 3 SAN CLEMENTE LOGO:**
1/4" DEEP ALUMINUM CUT OUT LETTERS. PAINT FINISHED. ATTACH LETTERS FLUSH TO SURFACE OF SIGN CABINET WITH BACK PINS AND EPOXY ADHESIVE.
- 4 MONUMENT COPY:**
3/8" DEEP CUT OUT ALUMINUM. PAINT FINISHED. ATTACH LETTERS FLUSH TO SURFACE OF SIGN CABINET WITH BACK PINS AND EPOXY ADHESIVE.
- 5 FOOTING:**
FULL CONCRETE FOOTING AS PER ENGINEERING CALCULATIONS.

FOR ENGINEERING SEE SHEET # 40.

FRONT ILLUMINATION :
LOCATE GROUND MOUNTED WHITE L.E.D. LIGHT TO ILLUMINATE FACE OF MONUMENT SIGN EVENLY. FIXTURE ON AT DUSK, OFF AT DAWN, OPERATES WITH AN AUTOMATED TIMER.
SOLAR OPTION:
SOLAR UPLITES FROM SOUTH COAST LIGHTING & DESIGN (949)-276-8850.

NOTE: COPY IS TYPICAL. EXACT COPY TO BE PROVIDED BY OWNERS.

IDENTIFICATION SIGNAGE

FILE NAME SanClem_DesInt 1-8			GRAPHIC SOLUTIONS ENVIRONMENTAL GRAPHIC DESIGN 2152 WOOD STREET - SUITE 105-60, SAN DIEGO, CA 92111 TEL (619) 238-1335 FAX (619) 235-8210
SHEET 08	DESIGNER AZ		

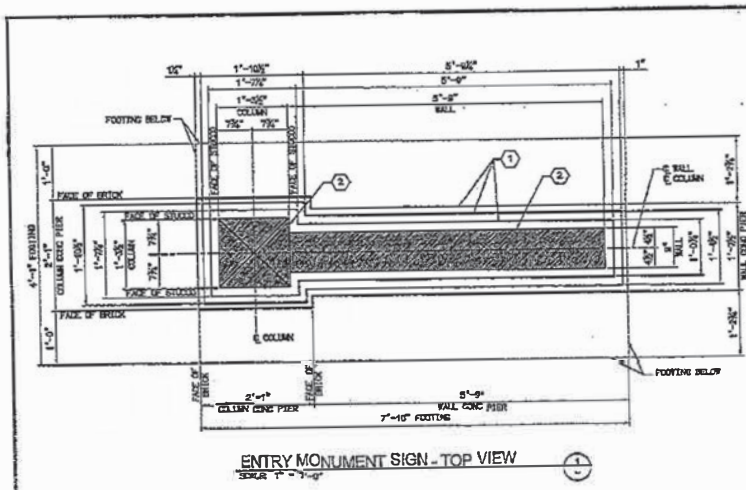

ENTRY MONUMENT SIGN - TOP VIEW
SCALE 1" = 1'-0"

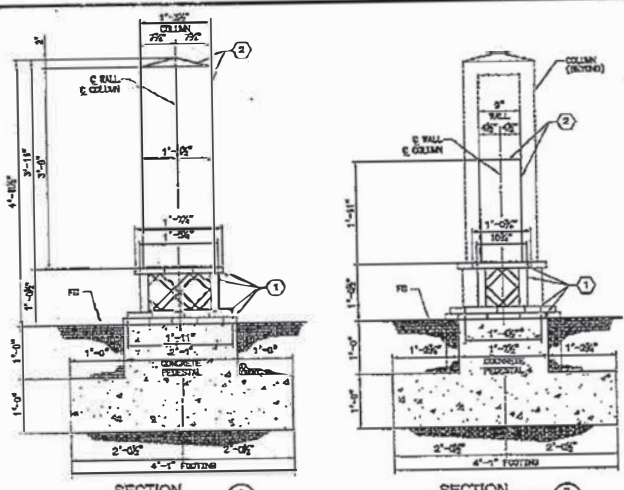

SECTION A-A
SCALE 1" = 1'-0"

SECTION B-B
SCALE 1" = 1'-0"

- GENERAL NOTES:**
1. SIGN LOCATIONS: IN GENERAL, ALL SIGNS TO BE LOCATED 2'-0" FROM EDGE OF CURB. SPECIFIC LOCATIONS MAY VARY.
 2. STUCCO FINISH/TEXTURE: SIGN FABRICATOR TO MAKE 3 SAMPLES OF 2'-0" X 2'-0" EACH ONE. THE SAMPLE TO BE OF HAND TEXTURED BRICK OR STUCCO. THE SAMPLE TO BE OF HAND TEXTURED STUCCO SHOULD BEIGHT TEXTURE TO SHOW THAT IT WAS HAND APPLIED. SEE SAMPLE TO BE OF HAND TEXTURED STUCCO, NOT TOO LIMPY.
 3. LETTERS MUST NOT BE CROOKED OR SLANTED WHEN VIEWED FROM ANY ANGLE.

- CONSTRUCTION NOTES:**
1. BRICK: MASONRY ENGINEERS GOLDEN BELMONT 720 BLEND WITH NATURAL GREY MORTAR. SIGN FABRICATOR TO SHOW BRICK PATTERN FOR INDICANT ON SHOP DRAWINGS.
 2. 1/2" THICK STUCCO LAYER. SOFT ROLLING EXPO. EXTERIOR STUCCO - WHITE WITH A HAND TEXTURED EFFECT. ALL EDGES TO BE EASSED.
 3. SAN CLEMENTE LOGO LETTERING: 1/2" DEEP ALUMINUM CUT OUT LETTERS (PANT FINISH). ATTACH LETTERS FLUSH TO SURFACE OF SIGN MASONRY WITH BRICK PINS AND EPoxy ADHESIVE. DRILL PILOT HOLES FOR THE PINS. PIN SPACING DEPTH TO BE 2". PAINT TO BE FLAT BROWN FINISH TO MATCH MATHEWS BROWN SOLES/02 MP 13333. FONT TO BE COBBY BOLD FONT.
 4. MORTAR BED: 1/2" DEEP ALUMINUM CUT OUT LETTERS (PANT FINISH). ATTACH LETTERS FLUSH TO SURFACE OF SIGN MASONRY WITH BRICK PINS AND EPoxy ADHESIVE. DRILL PILOT HOLES FOR THE PINS. PIN SPACING DEPTH TO BE 2". PAINT TO BE FLAT BROWN FINISH TO MATCH MATHEWS BROWN SOLES/02 MP 13333. FONT TO BE COBBY BOLD FONT.

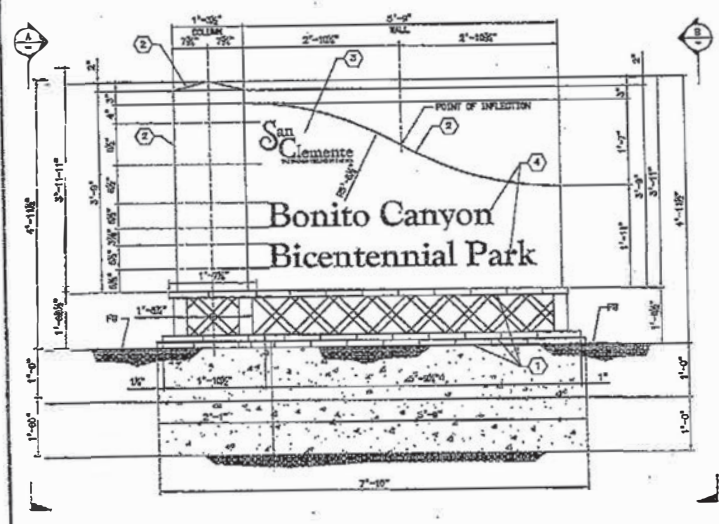

ENTRY MONUMENT SIGN - ELEVATION
SCALE 1" = 1'-0"

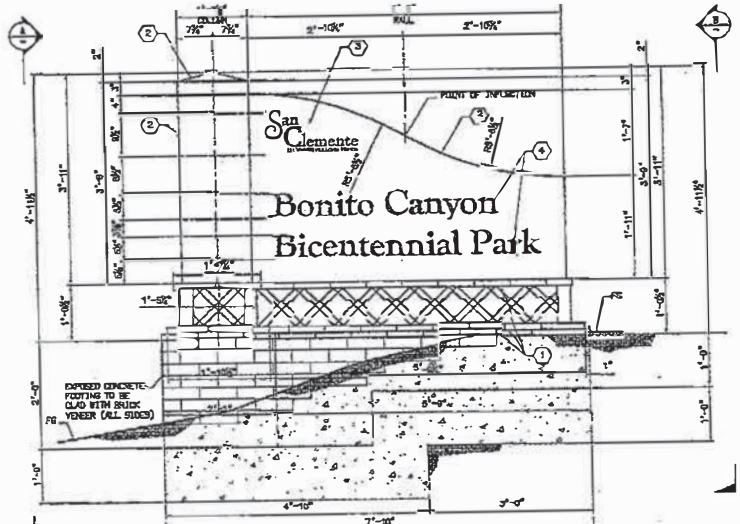

ENTRY MONUMENT SIGN - ELEVATION (EXPOSED FOOTING)
SCALE 1" = 1'-0"

APPROVED BY: _____
THOMAS A. BOWEN, PUBLIC WORKS DIRECTOR / CITY ENGINEER

REVISIONS		JOB NO.
NO.	DESCRIPTION	181405

SCALE: AS SHOWN
DESIGNED BY: A. CARAZZI

PREPARED UNDER THE SUPERVISION OF
Michael Baker INTERNATIONAL
DATE: 06/20/2020
SCALE: AS SHOWN

CITY OF SAN CLEMENTE
PARK MONUMENT SIGN REPLACEMENT PROGRAM
ENTRY MON. SIGN - MATERIALS AND FINISH

SHEET NO. 2 OF 4
S-1

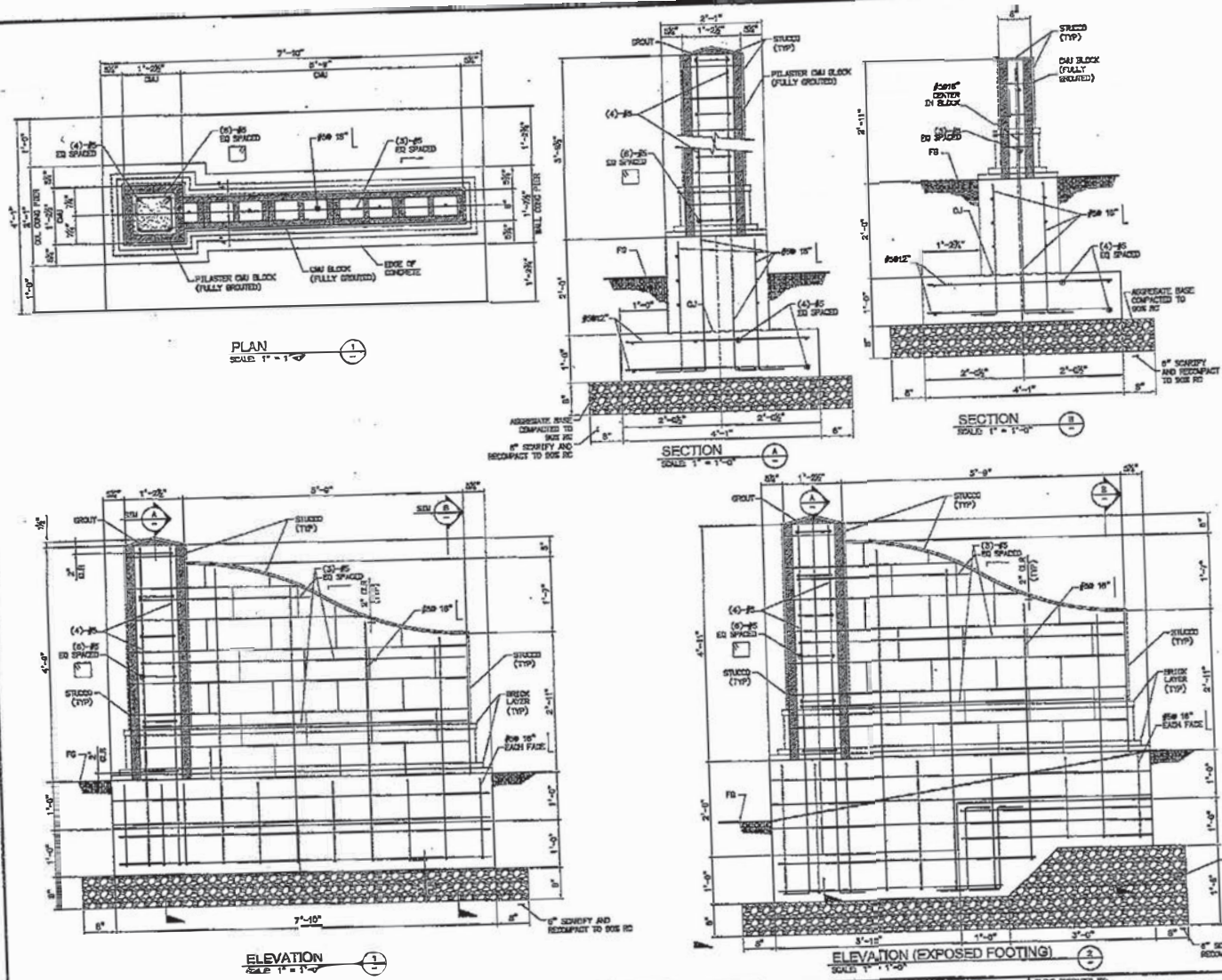

FOUNDATION

- ALL FOOTINGS SHALL BE EXTENDED 12" MINIMUM INTO COMPACTLY UNDISTURBED NATURAL SOIL OR CERTIFIED COMPACTED FILL, UNLESS NOTED OTHERWISE.
- SOILS BENEATH FOOTINGS SHALL BE PREPARED AND COMPACTED TO MINIMUM 90% REL.

CONCRETE

- CONCRETE SHALL HAVE AN 28-DAY ULTIMATE COMPRESSIVE STRENGTH AS SHOWN FOR THE CORRESPONDING LOCATION LISTED IN THE SCHEDULE BELOW.

LOCATION	STRENGTH (PSI)	DENSITY (PCF)	MAX WATER/CEMENT RATIO	COEFF. TYPE
ALL CONCRETE	4,500	150	0.5	TYPE V

REINFORCING STEEL

- REINFORCING STEEL SHALL BE DEFORMED BARS, CONFORMING TO ASTM A615, LATEST REVISION AND SHALL BE GRADE 60.

MASONRY

- CONCRETE MASONRY UNITS (CMU) SHALL BE GRADE N MEDIUM WEIGHT UNITS CONFORMING TO ASTM C90, WITH A MINIMUM COMPRESSIVE STRENGTH f_m OF 1,500 PSI.
- BLOCKS ARE 8"x8"x16" "HYBRID BLOCK" AND 16"x8"x16" PLASTER BLOCKOUT BLOCKS AS NEEDED.
- MORTAR SHALL CONFORM TO ASTM C270 AND SHALL BE TYPE S FOR REGULAR STRENGTH MASONRY WITH A MINIMUM 28-DAY COMPRESSIVE STRENGTH OF 1,000 PSI.
- GROUT SHALL CONFORM TO ASTM C910 AND SHALL HAVE A MINIMUM 28-DAY COMPRESSIVE STRENGTH OF 2,000 PSI FOR REGULAR STRENGTH MASONRY.
- ADJUSTERS AND ADJUSTERS TO MORTAR OR GROUT SHALL NOT BE USED UNLESS APPROVED BY THE ENGINEER. THE USE OF FLY ASH IS NOT PERMITTED AS AN ADJUSTIVE ADJUSTURE OR COARSE REPLACEMENT.
- MASONRY SHALL BE Laid IN RUNNING BOND AND SHALL BE FULLY GROUTED IN 4" MAXIMUM LIFTS.

SPECIAL INSPECTION

- SPECIAL TESTS AND INSPECTIONS SPECIFIED IN CHAPTER 17 OF THE CALIFORNIA BUILDING CODE ARE REQUIRED FOR THIS PROJECT. SPECIAL INSPECTIONS, EMPLOYED BY THE CITY SHALL CONTINUOUSLY OR PERIODICALLY, AS REQUIRED, MONITOR THE WORK AND PERFORM DUTIES SPECIFIED IN THE CODE DURING THE CONSTRUCTION OF THE FOLLOWING TYPES OF WORK:

ITEM	INSPECTION REQUIRED?	CBC 2019 SECTION	CBC 2019 TABLE	REMARKS
CONCRETE CONSTRUCTION	NO	-	-	
MASONRY CONSTRUCTION	YES	-	-	LEVEL 2 QUALITY ASSURANCE SHALL BE PROVIDED ON ALL CMU CONSTRUCTION PER TABLE 17.03.4 AND TABLE 17.03.5 (PROVIDED FOR CONTRACTOR'S CONVENIENCE)
SOILS	YES	1703.6	1703.6	

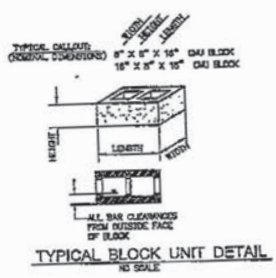

APPROVED BY: _____ DATE: _____

REVISIONS

NO.	DESCRIPTION	REVISED	APPROVED	DATE
1				

DESIGNED BY: A. GARZA
CHECKED BY: J. SHEN
DATE: 06/25/2021
SCALE: AS SHOWN

PLANS PREPARED BY: Michael Baker INTERNATIONAL
PREPARED UNDER THE SUPERVISION OF: _____
REGISTERED PROFESSIONAL ENGINEER
CITY OF CALIFORNIA
LICENSE NO. 70209
EXPIRES 06/30/2024

STATION CENTER DEL. 3075000
MAYAVILLE, CA 94552
MBA@MBA.COM

CITY OF SAN CLEMENTE
PARK MONUMENT SIGN REPLACEMENT PROGRAM
ENTRY MON. SIGN - PLAN, ELEV. & SECTIONS

SHEET NO.: 5-2
3 of 4

City of San Clemente
 Bidders' Listing for "Project Park Monument Sign Replacement Program (PN 29103 - August 2023)"
 Issued on 07/26/2023
 Bid Due on August 31, 2023 2:00 PM (PDT)

Vendor Name	Address	City	State	Zip	Bid Amount
America's Instant Signs	1260 N Hancock St Unit 106	Anaheim	CA	92807	\$62,790.02
premo construction inc	7 copper hill	Irvine	CA	92620	\$73,800.00
Bravo Sign and Design	520 S. Central Park Ave. E.	Anaheim	CA	92802	\$83,460.00
Abajian Enterprise	1640 E. EDINGER AVE STE C	Santa Ana	CA	92705	\$84,900.00
Oppenheimer national	31878 Del obispo st ste 118510	San Juan Capistrano	CA	92675	\$88,400.00
Corporate Project Management Inc	9130 Santa Margarita Road	Atascadero	CA	93422	\$152,580.00
newbuild Construction and restoration Inc	625 W. Katella ave ste 27	Orange	CA	92867	\$169,800.00

ATTACHMENT 6

RESOLUTION NO. 23-112

A RESOLUTION OF THE CITY COUNCIL OF THE CITY OF SAN CLEMENTE, CALIFORNIA, AWARDED A CONSTRUCTION CONTRACT TO A&D SIGNS CORP DBA AMERICA'S INSTANT SIGNS FOR THE PARK MONUMENT SIGN REPLACEMENT PROGRAM (AUGUST 2023), CIP PROJECT NO. 29103; AND AUTHORIZING THE CITY MANAGER TO EXECUTE THE AGREEMENT IN AN AMOUNT NOT TO EXCEED \$62,790

WHEREAS, on February 16, 2010, the City Council adopted Resolution No. 10-11, which approved the conceptual Master Wayfinding Sign Program; and

WHEREAS, on March 16, 2021, the City Council received and filed a plan design for park monument sign replacements, being consistent with the City's Wayfinding Sign Program; and

WHEREAS, Staff and an engineering consultant prepared a bid package to replace the wooden park monument signs at Max Berg Plaza and Marblehead Parks; and

WHEREAS, staff determined that the work was categorically exempt from the California Environmental Quality Act (CEQA) under Class 2 of the State CEQA Guidelines, Section 15302 – Replacement of Existing Facilities and a notice of exemption was filed with the County of Orange Recorder's Office on June 10, 2021 for this project; and

WHEREAS, on August 31, 2023, staff received seven responsive bids with bid amounts ranging between \$62,790 and \$169,800 with the lowest bid of \$62,790 being from A&D Signs Corp dba America's Instant Signs of Anaheim, California, to replace the aforementioned park monument signs.

NOW, THEREFORE, the City Council of the City of San Clemente does hereby find, determine and resolve as follows:

SECTION 1. That the above recitations are true and correct and incorporated herein.

SECTION 2. That the construction contract for the Park Monument Sign Replacement Program (August 2023), CIP Project No. 29103, is hereby awarded to A&D Signs Corp dba America's Instant Signs as the lowest responsive and responsible bidder.

SECTION 3. That the City Manager is authorized and directed to execute a construction contract with A&D Signs Corp dba America's Instant Signs in an amount not to exceed \$62,790 for CIP Project No. 29103 in a form substantially as presented to City Council on October 3, 2023.

SECTION 4. That a 10% project contingency of \$6,300 for CIP Project No. 29103

is hereby approved.

SECTION 5. That the City Clerk shall certify to the passage and adoption of this resolution and enter it into the book of original resolutions.

PASSED AND ADOPTED this ____ day of _____, 2023.

ATTEST:

City Clerk of the City of
San Clemente, California

Mayor of the City of San
Clemente, California

STATE OF CALIFORNIA)
COUNTY OF ORANGE) §
CITY OF SAN CLEMENTE)

I, LAURA CAMPAGNOLO, City Clerk of the City of San Clemente, California, do hereby certify that Resolution No. 23-112 was adopted at a regular meeting of the City Council of the City of San Clemente held on the ____ day of _____, _____, by the following vote:

AYES:

NOES:

ABSENT:

IN WITNESS WHEREOF, I have hereunto set my hand and affixed the official seal of the City of San Clemente, California, this ____ day of _____, _____.

CITY CLERK of the City of
San Clemente, California

Approved as to form:

Elizabeth A. Mitchell, City Attorney

Notice of Exemption

Appendix E

To: Office of Planning and Research
P.O. Box 3044, Room 113
Sacramento, CA 95812-3044
County Clerk
County of:

From: (Public Agency): City of San Clemente
Engineering Division, 910 Calle Negocio
San Clemente, CA 92673; Attn: Amir K. Ilkhanipour
(Address)

POSTED

Project Title: Park Monument Sign Replacement Program, PN 29103

JUN 10 2021

Project Applicant: City of San Clemente

ORANGE COUNTY CLERK-RECORDER DEPARTMENT

Project Location - Specific:

BY: [Signature] DEPUTY

Various parks in the City of San Clemente

Project Location - City: San Clemente Project Location - County: Orange

Description of Nature, Purpose and Beneficiaries of Project:

The project replaces 2 or 3 wooden park monument signs which have outlived their useful life and need to be removed and replaced.

FILED

Name of Public Agency Approving Project: City of San Clemente

Name of Person or Agency Carrying Out Project: City of San Clemente

JUN 10 2021

Exempt Status: (check one):

- Ministerial (Sec. 21080(b)(1); 15268);
Declared Emergency (Sec. 21080(b)(3); 15269(a));
Emergency Project (Sec. 21080(b)(4); 15269(b)(c));
[X] Categorical Exemption. State type and section number: Section 15302, Class 2
Statutory Exemptions. State code number:

ORANGE COUNTY CLERK-RECORDER DEPARTMENT

BY: [Signature] DEPUTY

Reasons why project is exempt:

Consistent with Section 15302, Class 2, the project consists of replacement of existing park monument signs.

Lead Agency

Contact Person: Manuel Gomez Area Code/Telephone/Extension: (949) 361-6187

If filed by applicant:

- 1. Attach certified document of exemption finding.
2. Has a Notice of Exemption been filed by the public agency approving the project? Yes No

Signature: [Signature] Date: 6-7-21 Title: Interim Public Works Director

Signed by Lead Agency Signed by Applicant

Authority cited: Sections 21083 and 21110, Public Resources Code.
Reference: Sections 21108, 21152, and 21152.1, Public Resources Code.

Date Received for filing at OPR:

Recorded in Official Records, Orange County
Hugh Nguyen, Clerk-Recorder



NO FEE

* \$ R 0 0 1 2 8 9 8 3 0 1 \$ *
202185000439 2:13 pm 06/10/21
383 VitIdx Z01
0.00 50.00 0.00 0.00 0.00 0.00 0.00 0.00

Handwritten notes: 8170-0418, 30-06/10/2021

Attachment 4

RESOLUTION NO. 24-61

A RESOLUTION OF THE CITY COUNCIL OF THE CITY OF SAN CLEMENTE, CALIFORNIA, ACCEPTING AS COMPLETE THE PARK MONUMENT SIGN REPLACEMENT PROGRAM (AUGUST 2023), MAX BERG PLAZA AND MARBLEHEAD PARKS, CIP PROJECT NO. 29103

WHEREAS, on October 3, 2023, the City Council awarded a construction contract to A&D Signs Corporation dba America's Instant Signs to replace park monument signs at Max Berg Plaza and Marblehead Parks, as part of the Master Wayfinding Sign Program, CIP Project No. 29103; and

WHEREAS, the work consisted of sign replacements at the Max Berg Plaza and Marblehead Parks; and

WHEREAS, A&D Signs Corporation dba America's Instant Signs has completed the work to the satisfaction of the Public Works Director.

NOW, THEREFORE, the City Council of the City of San Clemente does hereby resolve as follows:

Section 1. That the above recitations are true and correct.

Section 2. That the City Council accepts as complete the Park Monument Sign Replacement Program (August 2023), Max Berg Plaza and Marblehead Parks, CIP Project No. 29103, from A&D Signs Corporation dba America's Instant Signs.

Section 3. That the City Council authorizes the Public Works Director to execute and the City Clerk to record a Notice of Completion for the Park Monument Sign Replacement Program (August 2023), Max Berg Plaza and Marblehead Parks, CIP Project No. 29103.

Section 4. That the City Council authorizes the City Clerk to release the payment bond for this project 35 days from the recordation of the Notice of Completion upon verification with the Engineering Division that no liens have been levied against A&D Signs Corporation dba America's Instant Signs.

Section 5. The City Clerk shall certify to the passage and adoption of this resolution and enter it into the book of original resolutions.

PASSED AND ADOPTED this ____ day of _____, 2024.

ATTEST:

City Clerk of the City of
San Clemente, California

Mayor of the City of San
Clemente, California

STATE OF CALIFORNIA)
COUNTY OF ORANGE) §
CITY OF SAN CLEMENTE)

I, LAURA CAMPAGNOLO, City Clerk of the City of San Clemente, California, do hereby certify that Resolution No. 24-61 was adopted at a regular meeting of the City Council of the City of San Clemente held on the _____ day of _____, _____, by the following vote:

AYES:

NOES:

ABSENT:

IN WITNESS WHEREOF, I have hereunto set my hand and affixed the official seal of the City of San Clemente, California, this _____ day of _____, _____.

CITY CLERK of the City of
San Clemente, California

Approved as to form:

Elizabeth A. Mitchell, City Attorney

Notice of Exemption

Appendix E

To: Office of Planning and Research
P.O. Box 3044, Room 113
Sacramento, CA 95812-3044

From: (Public Agency): City of San Clemente
Engineering Division, 910 Calle Negocio
San Clemente, CA 92673; Attn: Amir K. Ilkhanipour

County Clerk
County of: _____

(Address)

POSTED

Project Title: Park Monument Sign Replacement Program, PN 29103

JUN 10 2021

Project Applicant: City of San Clemente

ORANGE COUNTY CLERK-RECORDER DEPARTMENT

Project Location - Specific:

BY: CF DEPUTY

Various parks in the City of San Clemente

Project Location - City: San Clemente Project Location - County: Orange

Description of Nature, Purpose and Beneficiaries of Project:

The project replaces 2 or 3 wooden park monument signs which have outlived their useful life and need to be removed and replaced.

Name of Public Agency Approving Project: City of San Clemente

FILED

Name of Person or Agency Carrying Out Project: City of San Clemente

JUN 10 2021

Exempt Status: (check one):

ORANGE COUNTY CLERK-RECORDER DEPARTMENT

- Ministerial (Sec. 21080(b)(1); 15268);
Declared Emergency (Sec. 21080(b)(3); 15269(a));
Emergency Project (Sec. 21080(b)(4); 15269(b)(c));
[X] Categorical Exemption. State type and section number: Section 15302, Class 2
Statutory Exemptions. State code number:

BY: CF DEPUTY

Reasons why project is exempt:

Consistent with Section 15302, Class 2, the project consists of replacement of existing park monument signs.

Lead Agency

Contact Person: Manuel Gomez Area Code/Telephone/Extension: (949) 361-6187

If filed by applicant:

- 1. Attach certified document of exemption finding.
2. Has a Notice of Exemption been filed by the public agency approving the project? Yes No

Signature: [Signature] Date: 6.7.21 Title: Interim Public Works Director

Signed by Lead Agency Signed by Applicant

Authority cited: Sections 21083 and 21110, Public Resources Code.
Reference: Sections 21108, 21152, and 21152.1, Public Resources Code.

Date Received for filing at OPR: _____

Recorded in Official Records, Orange County
Hugh Nguyen, Clerk-Recorder



NO FEE

* \$ R 0 0 1 2 8 9 8 3 0 1 \$ *

202185000439 2:13 pm 06/10/21

383 VitIdx Z01

0.00 50.00 0.00 0.00 0.00 0.00 0.00 0.00

8140-1802101790-00-0418