

STANDARD PROVISIONS  
AND  
STANDARD DRAWINGS  
FOR THE CONSTRUCTION OF  
WATER AND SEWERAGE FACILITIES



Approved William E. Cameron 6-28-00  
William E. Cameron, City Engineer Date

Revised \_\_\_\_\_ Date \_\_\_\_\_

\_\_\_\_\_ Date \_\_\_\_\_

<b>Document Cost:</b>	
Standard Provisions	\$ 5
Standard Drawings	\$10
Complete Document	\$15

## TABLE OF CONTENTS

<b><i>SECTION I - GENERAL CONDITIONS</i></b>		<b>5</b>
1.	INTENT OF STANDARD PROVISIONS AND STANDARD DRAWINGS FOR CONSTRUCTION OF WATER AND SEWERAGE FACILITIES	5
2.	TERMS AND CONDITIONS OF PERFORMANCE	5
3.	INDEMNIFICATION	8
4.	MISCELLANEOUS	9
<b><i>SECTION II - SPECIAL PROVISIONS</i></b>		<b>10</b>
1.	GENERAL REQUIREMENTS	10
2.	WATER SYSTEM DESIGN CRITERIA	10
3.	SEWERAGE SYSTEM DESIGN CRITERIA	11
4.	PREPARATION OF DRAWINGS	14
5.	DIGITAL SUBMISSION REQUIREMENTS FOR WATER AND SEWER IMPROVEMENT PLANS	17
<b><i>SECTION III – CONSTRUCTION MATERIALS</i></b>		<b>20</b>
1.	WATER SYSTEM	20
	Pipe	20
	Ductile Iron Pipe	20
	Polyvinyl Chloride (PVC) Pipe	20
	Ductile Iron Fittings	20
	Polyethylene Encasement Film	21
	Bolts and Nuts	21
	Connecting to Asbestos Cement Pipe	21
	Valves	21
	Resilient Wedge Gate Valves	22
	Butterfly Valves	22
	Tapping Valves	22
	Hydrants	22
	Air and Vacuum Relief Valve Assembly	23
	Pressure Reducing Station	23
	Back-flow Prevention Devices	24
	Concrete	24
	Pre-cast Concrete Vaults and Access Hatches	25
	Concrete:	25
2.	SEWERAGE SYSTEM	27
	Pipe	27
	Bolts and Nuts	27
	Concrete	27
	Pre-cast Concrete Manholes	28
	Sealing of Pre-cast Manhole Sections	28
	Manhole Frames and Covers	29
	Interior Liner/Coating	30
	Exterior Waterproofing	31
3.	PIPE CASING	31
<b><i>SECTION IV - INSTALLATION REQUIREMENTS</i></b>		<b>32</b>
1.	GENERAL	32
	Samples, Tests and Defective Material	32
	Pipe Bedding, Trench Backfill and Roadway Repair	32

Overexcavation	33
Earthwork	33
Protection/Reconstruction of Survey Monuments	34
Railroad Crossing	34
Blasting	34
Abandonment of Pipes and Appurtenances	34
Restoration and Cleanup	34
Record Drawings	35
2. WATER SYSTEM	35
Cut Sheets from Surveyor	35
Pipe	35
Tracer Wires for Non-Metallic Pipelines:	35
Valves	36
Hydrants	36
Tapping Sleeves	36
Service Laterals, Chlorination Assemblies, &Combination Air Relief Valve Connections	37
Concrete Thrust Blocking	37
Connections to Existing Water Mains	37
Disinfection of Water Mains and Services	38
Leakage Testing	40
3. SEWERAGE SYSTEM	41
Safety Requirements	41
Inspection	42
Cut Sheets from Surveyor	42
Scope of Inspection	42
Pipe	43
House Laterals	43
Connection to Existing Sewers	44
Manholes	44
Videotaping	45
Sewer Line Air Test	45
Manhole Testing	46

**SECTION V – STANDARD DRAWINGS** 47

<b>WATER STANDARD DRAWINGS</b>	47
W-1 1-Inch Water Service Assembly	47
W-2 2-Inch Water Service Assembly	47
W-3 Fire Hydrant Assembly	47
W-4 Valve & Valve Box Assembly	47
W-5 Tapping Sleeve and Valve Box Assembly	47
W-6 Thrust Blocks & Temporary Blow-Off / Chlorination Assembly	47
W-7 Thrust Block Details (Vertical)	47
W-8 Air & Vacuum Relief Valve Assembly	47
W-9 Pressure Reducing Station	47
W-10 Backflow Preventer Assembly (Dual Check Valve w/Detector)	47
W-11 Pipe Separation: New Water Mains From Sewer or Non-Domestic Water Mains	47
W-12 Fire Hydrant Barricades	47
W-13 3”, 4”, 6” 8”, & 10” Meter Installation	47
W-14 Waterline Header Installation	47

<b>SEWER STANDARD DRAWINGS</b>	<b>47</b>
S-1 Pipe Separation: New Sewers From Non-Domestic Water Mains or Domestic Water Mains	47
S-2 Standard Manhole	47
S-3 Manhole Base Plan	47
S-4 Standard Manhole Frame & Cover	47
S-5 Drop Connection to Standard Manhole	47
S-6 House Lateral Connection	47
S-7 Pipe Support of Perpendicular Crossing	47
S-8 Sewer Saddle Wye & Cut-In Wye Connection for Sewer Laterals	47
S-9 Clean Out Detail	47
<b>OTHER STANDARD DRAWINGS</b>	<b>48</b>
WS-1 Pipe Bedding Trench Backfill and Roadway Repair	48
WS-2 Anchor Block for Pipes Installed in Slopes Greater Than 30%	48
WS-3 Pipe Casing	48



## **SECTION I - GENERAL CONDITIONS**

### **1. INTENT OF STANDARD PROVISIONS AND STANDARD DRAWINGS FOR CONSTRUCTION OF WATER AND SEWERAGE FACILITIES**

The intent of the Standard Provisions and Standard Drawings for Construction of Water and Sewerage Facilities, herein referred as “water and sewer standards”, is to describe a complete work of improvement which applicant, hereon referred as “contractor” shall perform or cause to be performed in a manner acceptable to the City Engineer and in full compliance with all codes and the terms of the water and sewer standards. Contractor shall complete a functional or operable improvement or facility, even though the water and sewer standards may not specifically call out all items of work required for the Contractor to complete the tasks, incidental appurtenances, materials, and the like. If any omissions are made of information necessary to carry out the full intent and meaning of the water and sewer standards, Contractor shall immediately seek approval of the City Engineer for furnishing detailed instructions. In the event of any doubt or question regarding the true meaning of any of the water and sewer standards or any portion thereof, reference shall be made to the City Engineer whose decision thereon shall be final.

### **2. TERMS AND CONDITIONS OF PERFORMANCE**

All work performed under the water and sewer standards shall comply with the latest edition of that document entitled "Standard Specifications For Public Works Construction," published by Building News, Inc. (the "Standard Specifications"), which is incorporated herein by this reference as if set forth in full, except the following provisions of the Standard Specifications are hereby amended and supplemented as follows:

- A. Section 1-2 of the Standard Specifications, entitled "Definitions," is hereby amended and supplemented as follows:

"Agency" – The City of San Clemente

"Applicant" - An owner, hereon referred as “contractor”, his developer, builder, engineer, or other authorized representative who applies as the owner’s official agent to the City.

"Board" - The City Council of the City of San Clemente or its designee.

"Engineer"- The City Engineer of the City of San Clemente or his designee.

“Inspector”- Person authorized by the City Engineer to perform all inspection duties.

B. Section 2-5.2 of the Standard Specifications, entitled “Precedence of Documents” is hereby amended and supplemented as follows:

1. Permits from other Agencies as may be required by law.
2. The City of San Clemente Municipal Code, Chapter 8.16, “Uniform Fire Code Adopted”.
3. The City of San Clemente Municipal Code, Chapter 13.04, “Water Service System”.
4. The City of San Clemente Municipal Code, Chapter 13.24, “Sewer Service System”.
5. Plans and Specifications approved by the City Engineer.
6. Condition of Approvals and/or Permits issued by the City of San Clemente.
7. Latest editions of City of San Clemente Standard Provisions and Standard Drawings for construction of water and sewerage facilities.
8. "Standard Specifications for Public Works Construction", Latest Edition, published by Building News, Inc.
9. American Water Works Association Standards (AWWA), Latest Edition.
10. O.C.E.M.A. Standard Plans, Latest Edition.
11. "Uniform Building Code", Latest Edition.
12. "Uniform Plumbing Code", Latest Edition.
13. "Uniform Mechanical Code", Latest Edition.
14. "National Electric Code", Latest Edition.
15. "American Disabilities Act (ADA) Handbook", Latest Edition.

All traffic related improvements shall comply with the applicable portions of:

- "Standard Plans", State of California, Department of Transportation, Latest, 1992 Edition.
- The Work Area Traffic Control Handbook, W.A.T.C.H. Manual, Latest Edition.
- "Standard Specifications", State of California, Department of Transportation, Latest Edition.
- "Traffic Manual", State of California, Department of Public Works, Division of Highways, Latest Edition.

- C. Section 6-8 of the Standard Specifications, entitled "Completion and Acceptance," is hereby amended to read in its entirety as follows:

6.8 Completion and Acceptance, Defective Work

6.8.1 Completion

Contractor shall make an initial request for final inspection after initial completion of the Work. After inspection, the Engineer will inform the Contractor, in writing, of all items found by Engineer to be incomplete or not in compliance with the project plans and specifications. After the Contractor has completed these items, the procedure for final inspection shall then be the same as specified above for the Contractor's initial request for final inspection. If after two (2) "final" inspections, items are found by Engineer to be incomplete or not in compliance with this water and sewer standards or any of the requirements contained or referenced herein, City may require Contractor, as a condition of City performing further field inspections, to submit to the Engineer a detailed written statement of the work performed subsequent to the date of the previous inspection at which such items were found to be incomplete or not in compliance with this water and sewer standards. The Parties shall follow the above steps until such time as Engineer determines that the Work has been satisfactorily completed in accordance with all terms and condition of this water and sewer standards.

6.8.2 Defective Work

Contractor shall repair, reconstruct, replace or otherwise make acceptable any and all Work found by Engineer to be defective or not in accordance with the water and sewer standards. Final acceptance of the Work shall not constitute a waiver by City of any defective work subsequently discovered.

- D. Section 7-3 of the standard specifications entitled "liability insurance" here by amended to read that the following insurance coverage shall be provided. All other provisions of Section 7-3 remains in effect:

General and Automobile Liability Insurance:

Bodily Injury: \$1,000,000 each person  
\$2,000,000 each occurrence  
\$2,000,000 aggregate products & completed operations

Property Damage: \$500,000

A combined single limit policy with aggregate limits in the amount of \$2,000,000 will be considered equivalent to the required minimum limits.

Endorsement for Liability Insurance:

The Certificate of Insurance and insurance shall:

- a) Name and list as additional insured the City and the City of San Clemente Redevelopment Agency. An endorsement shall accompany the insurance certificate naming the City of San Clemente, its elected officials, officers, agents, and employees as additional insureds; and the City of San Clemente Redevelopment Agency when appropriate.
- b) Specify that it acts as the primary insurance and that no insurance held or owned by City shall be called upon to cover a loss under said policy.
- c) Contain a clause substantially in the following words: "It is hereby understood and agreed that this policy may not be canceled or materially changed except upon 30 days prior written notice to City of such cancellation or material change as evidenced by a return receipt for a registered letter."
- d) Cover the operations of Contractor in the City.
- e) Be written on an occurrence and not a claims made basis.

- E. Section 7-8.6 of the Standard Specifications, entitled "Water Pollution Control," is hereby amended to read in its entirety as follows:

#### 7.8.6 Water Pollution Control:

Contractor shall be required to obtain, at its sole cost and expense, the requisite National Pollutant Discharge Elimination System Permit, and comply with all terms and conditions thereto. In addition, Contractor shall exercise every reasonable precaution to protect channels, storm drains, and bodies of water from pollution and shall conduct and schedule its operations so as to minimize or avoid muddying and silting of said channels, drains, and waters. Water pollution control work shall consist of constructing those facilities which may be required to provide prevention, control, and abatement of water pollution.

### **3. INDEMNIFICATION**

Contractor shall indemnify, defend, and hold harmless the City of San Clemente "City" and City's officers, employees, and agents ("City Releases") from and against any and all claims, liabilities, losses, damages, causes of action, and obligations arising out of Contractor's failure to perform the construction and installation of the Work in accordance with the requirements

contained or referenced in this “Standard Provisions and Standard Drawings for the Construction of Water and Sewerage Facilities” (“Claims”). Said indemnity obligation shall apply to personal injury, death, property damage, economic loss, and any other monetary damage or penalty to which City may be subjected, whether or not the injury, damage, or loss is covered by insurance. In connection therewith:

- A. Contractor shall defend any action or actions filed in connection with any of such Claims, and shall pay all costs and expenses, including attorneys’ fees, incurred in connection therewith.
- B. Contractor shall promptly pay any judgment rendered against Contractor or any City Releasee covering any Claim, and Contractor shall save and hold each and all of the City Releasees harmless therefrom.
- C. In the event any City Releasee is made a party to any action or proceeding filed or prosecuted against Contractor for any Claim, Contractor shall pay to the City any and all costs and expenses incurred by any City Releasee in such action or proceeding, together with reasonable attorneys’ fees.

#### **4. MISCELLANEOUS**

- A. License, Permits and Fees: The Contractor performing water sewer facilities construction shall have a valid Contractor’s license of the appropriate class and a City business license. The Contractor shall obtain all permits, pay all fees, and give all necessary notices required for the construction of the work.
- B. Encroachment Permit: No operations, excavation posting, signing or work of any kind shall be performed in the City of San Clemente Right-of-Way without an Encroachment Permit.
- C. Any work started prior to obtaining the appropriate permits is subject to triple permit fees. CAL/OSHA permits shall be maintained on site.
- D. Plan Checking and Approval by City Engineer: Construction drawings for City Facilities shall be approved by the City Engineer and attested to by his signature on the drawings. The City Engineer’s approval attests only to general design concepts and Master Plan compliance. Adequacy of adherence to City Standards, maintenance procedures and quality of materials will be reviewed. Approval does not guarantee the absence of errors and omissions subsequently discovered and does not preclude correction by the contractor.

## **SECTION II - SPECIAL PROVISIONS**

### **1. GENERAL REQUIREMENTS**

Water and Sewer service systems shall comply with the requirements stipulated in and the latest Master Plans adopted by the City. The Contractor is responsible for determining and showing the location of all utilities on the water plan including storm drain and “dry” utilities.

Fire protection system shall comply with the requirements stipulated in Municipal Code, and secure approval from Orange County Fire Authority. When requested, the contractor shall submit for City Engineer approval a hydraulic analysis of the system flow capabilities to critical areas. This computerized network analysis shall include scenarios of fire flows at various hydrants that evidence the capability of the system to deliver the required flows at all locations in the development. The owner shall furnish a certified flow test to verify flows predicted by the network analysis. Actual flow measurements must comply with the above requirements. Water and Sewer system design shall comply with pipe separation standard W-11 and S-1.

### **2. WATER SYSTEM DESIGN CRITERIA**

- A. Design of Water System will comply with the American Water Works Association (AWWA) Standards, Latest Edition.
- B. The minimum Water Main pipe size shall be 8”.
- C. The minimum water pressure available to any site within the subdivision shall be 40 psi.
- D. The maximum water pressure available to any site within the subdivision shall be 90 psi.
- E. All valves and fittings, where directional or elevation changes occur and as deemed necessary by the Engineer, shall be thrust blocked with concrete.
- F. Locations of house connections shall be indicated on plans as 1” or 2” water service assembly.
- G. Dead Ends (unlooped) water mains shall not exceed 500 ft. in length. Looping is required and may necessitate easements to complete loops if cul-de-sacs are longer than 500 ft.
- H. Depths to top of pipe below finished grade shall not be less than 36 inches. Normal design depth to top of pipe, with no interference, shall be 42 inches with a maximum depth of 48 inches. Altering grade and depths because of interference requires approval prior to laying pipe to avoid the interference. The Contractor must, prior to beginning

trenching and laying; a) excavate, b) pothole to anticipate conflicts and verify plan depths if approved plans show a possible conflict. Grade and depth alterations that become necessary because of conflicts or interferences not shown on approved plans require City Engineer's approval and prior to performance of the work and may require special pipe casing or concrete encasement.

- I. Horizontal location of water mains is to be six feet from the curb face.
- J. Valves shall be located on mains using the following criteria:
  - a) Tees\_– 3 valves – one on each run adjacent to the tee.
  - b) Crosses – 4 valves – one on each run adjacent to the cross.
  - c) No more than one fire hydrant shall be out of service at one time interval for a single main shutdown.
  - d) No more than 24 service connections shall be out at one time.
- K. Design of all metal pipe construction shall include measures for soil corrosion protection, including but not limited to cathodic protection.

**3. SEWERAGE SYSTEM DESIGN CRITERIA**

- A. Minimum sewer main shall be 8-inch diameter. The minimum velocity of flow in the sewer main shall be greater than 2-feet per second at average flow ( $Q_{ave}$ ). The sewer main shall be designed to flow 50 percent full at peak flow ( $Q_{peak}$ ). Minimum pipeline slopes shall be:

<u>Pipe Size</u>	<u>Grade</u>
8-inch	0.40%
10-inch	0.28%
12-inch	0.22%
15-inch	0.16%

- B. Minimum sewer house lateral shall be 4-inches. Minimum commercial/industrial lateral shall be 6-inches. All laterals shall have a minimum slope of 2%.
- C. Manholes are required for the following conditions:
  - a) at changes of slope
  - b) at changes of direction
  - c) at junction of laterals larger than 6 inches
  - d) at changes of pipe size
  - e) at termination of sewers
  - f) at a maximum of 300 ft. spacing
  - g) at special locations designated by the Engineer.



- D. Manhole size shall be 48" interior diameter with 24" diameter manhole opening for sewer line sizes 10" and less and 60" diameter with 30" diameter manhole opening for sewer pipelines 12" and greater.
- E. The minimum radius for curves for PVC lines shall be 175 feet for 8-inch to 12-inch sewer mains and 230 feet for 15-inch to 18-inch mains. All VCP pipe shall be designed without radius.
- F. Sewer Peak flow shall be calculated by using the following formula:  

$$Q_{\text{peak}} = D \times Q_{\text{ave}}^{0.92}$$
 Where  $Q_{\text{peak}}$  = Peak Flow in Cubic Feet Per Second and  
 $Q_{\text{ave}}$  = Average Flow in Cubic Feet Per Second  
 D = 1.84 for mixed land use  
 D = 2.10 for residential land use  
 Unless otherwise directed by the City Engineer, the following Wastewater Unit Flow Factors will be applied to the total drainage area to calculate  $Q_{\text{ave}}$ .

## WASTEWATER UNIT FLOW FACTORS

Land Use		Unit Flow		
Use	Description	Units	Flow	Units
1	Res – Low	DU	257	GAL/DU/DAY
2	Res – Low/Medium	DU	247	GAL/DU/DAY
3	Res – Medium	DU	142	GAL/DU/DAY
4	Res – Medium/High	DU	142	GAL/DU/DAY
5	Res – High	DU	142	GAL/DU/DAY
6	Mixed Use	TSF	295	GAL/TSF/DAY
7	Commercial	TSF	164	GAL/TSF/DAY
8	Industrial/Business Park	TSF	150	GAL/TSF/DAY
9	Heavy Industrial	TSF	245	GAL/TSF/DAY
10	Restaurant/Bar	TSF	1225	GAL/TSF/DAY
11	Hotel/Motel/Resort	ROOM	165	GAL/ROOM/DAY
12	Theater	SEAT	10	GAL/SEAT/DAY
13	Service Station	STAT	900	GAL/STAT/DAY
14	Auto – Sales	AC	1000	GAL/AC/DAY
15	Auto – Repair	TSF	175	GAL/TSF/DAY
16	Sports Complex	AC	10	GAL/AC/DAY
17	School	STU	10	GAL/STU/DAY
18	Church	TSF	100	GAL/TSF/DAY
19	Golf Course/Park/Utility	AC	10	GAL/SC/DAY
20	Hospitals	BED	98	GAL/BED/DAY
21	Congregate Care	ROOM	98	GAL/ROOM/DAY

DU: Dwelling Unit  
 TSF: Total Square Feet  
 STAT: Station  
 AC: Acre  
 STU: Student

#### **4. PREPARATION OF DRAWINGS**

All water and sewer plans shall be prepared under the direct supervision and signed by a Registered Civil Engineer registered in the State of California. The drawings shall be prepared in accordance with the "City of San Clemente Public Works Department, Engineering Division, Plan Preparation Guidelines". This document can be obtained from the City Engineer's office. The drawings shall include:

- Sheet size: 24 by 36 inches
- Scales: Horizontal – one inch equals 40 feet.  
Vertical – one inch equals 4 feet for slopes less than 10%.  
One inch equals 8 ft. for slopes greater than 10%.
- Plans: Water and sewer plan and profile shall be prepared separate from street improvement plans and shall show necessary items for the construction of the proposed facilities.
- Easements: Generally, water and sewer lines shall be located in the street. Easements shall be a minimum of 15 feet in width and shall be shown on the plans. All easements shall be recorded on the tract map and granted to the City.
- Sewer Lateral and Water Service Line Locations: Location shall be indicated by placing a box around each station number.
- Standard Notes: The following notes shall be included on the first or second sheet of the plans:

##### **General Notes for Water and Sewerage Construction:**

- G-1 A permit and an approved plan is required for all work on City Facilities.
- G-2 Inspection shall be scheduled by mail, or fax, 24 hours in advance, and sent to City Engineering Inspection, 910 Calle Negocio, Suite 100, San Clemente, CA 92673, or faxed (949) 361-8316.
- G-3 All water and sewerage facilities shall conform to the City's "Standard Provisions and Standard Drawings for the Construction of Water and Sewerage Facilities", Latest Edition, herein referred as the "City Water and Sewer Standards". The contractor shall have a copy of approved plans, permits and the Water and Sewer Standards on the job at all times.

- G-4 The City shall be furnished with three (3) sets of approved plans prior to starting construction.
- G-5 Facilities not in dedicated City right of way shall not be connected to a public facility until the City has accepted and recorded an easement for the facilities. A copy of the recorded easement shall be provided to the inspector prior to any connection being made in the field.
- G-6 Backfill of underground work before inspection will result in the work being rejected.
- G-7 The Contractor shall remove or abandon all unused water and sewerage facilities per the Water and Sewer Standards.
- G-8 Construction sites shall be maintained in such a condition that rain does not wash wastes or pollutants off site or into a connected sewer or storm drain.

Discharges of material other than storm water are allowed only when necessary for performance and completion of construction practices and where they do not: Cause or contribute to a violation of any water quality standard; cause or threaten to cause pollution, contamination, or nuisance; or contain a hazardous substance in a quantity reportable under Federal Regulations 40 CFR Parts 117 AND 302.

Potential pollutants include but are not limited to: solid or liquid chemical spills; wastes from paints, stains, sealants, glues, limes, pesticides, herbicides, wood preservatives and solvents; asbestos fibers, paint flakes or stucco fragments; fuels, oils, lubricants, and hydraulic, radiator or battery fluids; fertilizers, vehicle/equipment wash water and concrete wash water; concrete, detergent or floatable wastes; wastes from any engine/equipment steam cleaning or chemical degreasing; and superchlorinated potable water line flushings.

During construction, disposal of such materials should occur in a specified and controlled temporary area on-site, physically separated from potential storm water run-off, with ultimate disposal in accordance with Local, State and Federal Requirements.

- G-9 De-watering of contaminated groundwater, or discharging contaminated soils via surface erosion is prohibited. De-watering of non-contaminated groundwater requires a National Pollutant Discharge Elimination System Permit from the respective State Regional Water Quality Control Board.

## **Notes for Water Construction**

- W-1 Shutdown of existing waterlines to facilitate connection of new facilities requires an acceptable, approved schedule with the City water operations, Engineering and Fire Authority before shutdown.
- W-2 Identify all water service locations with a 2" high "W" stamped or chiseled into the curb face.
- W-3 All irrigation services shall be provided with approved pressure regulators (Watt's Series 223 or approved equal) set at 60 p.s.i. on the customer side of the meter where the water main pressure exceeds 70 p.s.i.
- W-4 Disinfection shall be scheduled with the Inspector and shall be directed by the Construction Superintendent.

## **Notes For Sewerage Construction**

- S-1 Service lateral locations shall be clearly marked with a 2" high "S" chiseled in the curb face by the Contractor.
- S-2 Manhole covers shall be adjusted as streets are constructed.
- S-3 Sewer lines with end plugs shall be marked by a vertical 2" x 4" redwood or 4" diameter PVC pipe extending vertically to 2-ft. below finished grade.
- S-4 Minimum sewer cover shall be 6 feet below subgrade. If, during construction, sewer is found to have less than 6 feet of cover, sewer shall be encased in concrete.
- S-5 Stations shown thus 0+00 as shown on the plan and profile are sewer stations and are independent of street stations and are stations along centerline of sewer from downstream manhole.
- S-6 Contractor shall verify the horizontal and vertical location of all utility crossings before constructing any sewers.
- S-7 The Contractor shall protect in place all existing utilities, whether or not shown on these plans.
- S-8 Manhole cones shall be set straight side upstream. Manhole steps shall be made of steel reinforced polypropylene.

## **5. DIGITAL SUBMISSION REQUIREMENTS FOR WATER AND SEWER IMPROVEMENT PLANS**

To facilitate the transfer of information into the City's Geographic Information System (GIS), all plan submittals will be required to include digital graphic files in addition to the hard copy plans. Hard copy plans shall be prepared in accordance with the "City of San Clemente Public Works Department, Engineering Division, Plan Preparation Guidelines." Digital submittals shall be prepared in accordance with this document and will be required prior to final approval of plans by the City. Guidelines listed below may be revised by the City Engineer, periodically.

- Design Guidelines

1. Prepare drawings in model space (real earth coordinate). Use State Plane, California Zone VI, NAD 83 datum, units in feet, in accordance with the County of Orange Standards.
2. Tie two existing horizontal control points (minimum). Show locations of the points and bearing/distance/curve info.
3. Design with continuous polylines, NEVER use curves in a polyline because they will not export to the GIS system.
4. Draw each parcel and/or building footprint with a polyline to form a closed polygon.
5. Use standard symbol blocks from City diskette for utility features.
6. Use paper space for any titleblock, legend, index, etc. information. Separate paperspace layers from design work and use easily recognizable layer names. Use standard AutoCAD fonts.
7. Submit separate drawing files for details of all utility stations (i.e. pump stations, pressure reducing stations, reservoirs, etc.) and complex valve configurations.

- File Format and Media Requirements

Digital files shall be AutoCAD .dwg files if possible. If necessary, the City may accept ArcView .shp files or Microstation .dgn files. Image files (.tif, .pdf, .jpg, etc.) will NOT be accepted under any circumstances.

Digital files shall be submitted on 3.5" diskette or CD. The diskette or CD shall include a readme file in .doc or .txt format which will include an index of drawings and any explanations the city may need to use the digital files. The diskette or CD shall also include any data decompression software needed to extract the files.

- Data Layering Requirements

The following layer table details information which shall be included in ONE drawing file. For all new developments, each layer and its inclusions are REQUIRED. For improvements on existing facilities, include those layers necessary to show the new design in relation to existing conditions. For improvements only, existing conditions should be colored GRAY, new design shall follow the layer table.

<b>LAYER</b>	<b>DESCRIPTION</b>
BLDG	Building Footprints
BNDRY	Tract Boundary Lines
CATCH-B	Catch Basin
CL	Street Centerline
CURB	Curb Lines
GAS	Gas Lines
GUTTER	Gutters
EASEMENT	Easement Lines
ELECT	Electrical Lines
ELEV	Elevation and Contours
LOT	Lot Lines
M-HOLE	Manhole
SIDEWALK	Sidewalks
SD	Storm Drain Centerlines
SD-WALLS	Storm Drain Walls
SEWER	Sewer Lines
WATER	Water Lines
ROW-PUB	Public Right of Way Lines
ROW-PRI	Private Right of Way Lines

Add additional layers ONLY as necessary for clear depiction.



- Checking of Digital Submittal

Digital data will be checked for the following:

1. Correct layering
2. Correct coordinate system.
3. Correct use of polylines in design.
4. Consistency between digital and hard copy plans.

## **SECTION III – CONSTRUCTION MATERIALS**

Submittals for all construction materials are required for all water and sewer installations for the City Engineer's approval prior to commencement of construction. Submittals shall consist of the appropriate combination of catalog sheets, material lists, manufacturer's brochures, technical bulletins, specifications, diagrams, or product samples, necessary to describe a system, product, or item. Submittals for systems shall be bound together and include all manufactured items for the system. Six copies of each submittal shall be transmitted to the Engineer. If no change or correction is required, three approved copies will be returned to the Contractor.

### **1. WATER SYSTEM**

#### ***Pipe***

Pipe for water main shall be a minimum of 8-inch diameter. Pipe materials shall be Ductile Iron or Ductile Iron outside diameter PVC AWWA C900. Pipe material for pipelines 10-inch and greater shall be Ductile Iron. Service lines shall be type K copper. Where pipes larger than 12 inch are required, special plan profile submittal for specific approval from the City Engineer is required.

#### ***Ductile Iron Pipe***

Ductile iron pipe shall be pressure class 350 psi with push-on or mechanical joints. Ductile iron pipe shall be manufactured per ANSI A21.50/AWWA C150. Ductile iron pipe shall be cement mortar lined with type V cement per ANSI A21.4/AWWA C104. Outside coating shall be asphaltic coating 1 mil thick per ANSI 21.51/AWWA C151. Joints and Gaskets shall be push on with joint dimensions and gaskets per ANSI A21.51

#### ***Polyvinyl Chloride (PVC) Pipe***

Polyvinyl Chloride (PVC) pipe shall be class 200, DR 14 made in accordance with ASTM D1784. Elastomeric gaskets shall comply with ASTM F477. Gaskets shall be "locked in", factory installed, in accordance with ASTM D 3139.

#### ***Ductile Iron Fittings***

Ductile iron fittings, meeting the requirements of ANSI A21.53 and AWWA C153 shall be used for ductile iron and C900 PVC. Where flanged fittings are used, the gaskets shall be raised face.

Mechanical joint fittings shall be used where required or approved in specific locations by the City Engineer. Flanged fittings shall comply with ANSI B16.1, B16.2 and A21.53 or ANSI/AWWA C110/A21.10.

Ductile iron flanges, designed for a working pressure of 200 psi or less, shall be Class 125 template pattern. Where water pressures may exceed 200 psi, details for specific approvals by the City Engineer must be submitted during design.

### ***Polyethylene Encasement Film***

Polyethylene Encasement Film shall be installed with all Ductile Iron Pipe, Ductile Iron fittings including fittings on PVC pipe and all buried valves and ferrous appurtenances. Encasement film shall meet the requirement of ANSI/AWWA A21.5/C105 and ASTM 674 and be 8 mil thick. Polyethylene film must be color coded blue for water pipe.

### ***Bolts and Nuts***

All bolts, nuts, and washers shall be 316 stainless steel and torqued to manufacturer's specifications.

### ***Connecting to Asbestos Cement Pipe***

Connecting to asbestos cement pipe requires ductile iron fittings with gaskets accommodating appropriate outside dimensions of the AC pipe being connected. O.D. of AC pipe shall be measured prior to commencement of the connection work to reduce water system shutdown time.

### ***Valves***

Valves shall be resilient wedge gate valves with the following exceptions: 1) Where water line depths to top of pipe do not allow the operating nut to be a minimum of 18 inches below the finished surface, consideration will be given for approval of butterfly valves with right angle gear operators; 2) Pipe sizes larger than 12 inches in diameter.

Flanges of valves designed for a working pressure of 200 psi or less shall be faced and drilled to a 125-pound American Standard dimension. Flanges of all valves designed for a working pressure of greater than 200 psi shall be faced and drilled to 250-pound American Standard dimensions.

All interior parts of valves shall be manufactured of bronze or brass, except valve stems, and shall conform to the requirements of ASTM B 62. Gate valve stems

shall be of low zinc content (2%), having a minimum tensile strength of 70,000 psi, a yield strength of 40,000 psi, and 12% elongation in 2 inches. The stem is to be visibly marked so that it meets this requirement. Valves shall be provided with a stem extension if depth of valve nut exceeds 4 feet from finished surface. All valve extensions shall operate freely without holding or binding after installation.

All valves connecting to fittings shall be flanged to the fitting.

### ***Resilient Wedge Gate Valves***

Resilient wedge valves shall conform to the latest edition of AWWA C509. Valves shall be of the class and end type shown on the plans, and may be used only for nominal pipe sizes from 3 inches to 12 inches in diameter. The cast-iron wedge shall be fully encapsulated with resilient material to meet ASTM tests for rubber to metal bond ASTM D429. Body bolts, nuts, and washers shall be Type 316 stainless steel. Valves shall be provided with a 2-inch square operating nut and open by turning counter clockwise. Coatings shall comply with AWWA C-550. Valves shall be M&H Style 4067, Mueller 2360 Series or American Flow Control Series 2500.

### ***Butterfly Valves***

If their installation is approved, butterfly valves shall conform to the latest edition of AWWA C504. Valves shall be of the class and end type shown on the plans. Shaft seals shall be designed for use with standard split-V type packing. The resilient valve seat shall be secured to the disk. The inside port diameter of the valve shall not be more than one inch smaller than the nominal diameter of the equivalent pipe size. All body bolts shall be Type 316 stainless steel. Valves shall be provided with a right angle geared operator with a 2-inch square operating nut opening by turning counter clockwise. Operators shall be made by the same manufacturer. Valve coating shall be fusion bonded epoxy per ANSI/AWWA C550. Valves shall be M&H 4500; Pratt Groundhog or Mueller Line Seal III.

### ***Tapping Valves***

Tapping valves shall be Resilient Wedge Gate Valves.

### ***Hydrants***

Fire hydrants shall be cast iron, Class A of the wet barrel type. Hydrants shall have (2) two 2-1/2 inch hose connections, and a 4-inch pumper connection. The hydrant's connection to the main shall be provided with a 6-inch resilient wedge gate valve. Unless specified otherwise, all hydrants shall have a bury of 42 inches in depth, and a 6-inch rubber ring bell inlet for ductile iron pipe. Any required

extension spools shall be supplied by the same manufacturer as the fire hydrant. The operating nuts shall be the standard 1-1/2 inch pentagon shape, opening counter clockwise. All hydrant flanges shall be six-hole regular, 125 pound American Standard flange drilling. Hydrants shall comply fully with AWWA Standard C-503-88 and be UL Approved.

Furnish and install breakaway bolts for hydrant head mounting and 316 stainless steel bolts, nuts, and washers for installing underground base shoes.

Hydrants shall be James Jones Co. J4060D or Clow 860 or AVK model #24-150-50 with 4-inch Pumper Nozzle. Paint shall be Pervo 2420 safety yellow coating or HP Fuller paint hybrid yellow IF-6720. Finish coating shall be applied at the factory prior to shipment.

Hydrants shall be utilized to flush lines and serve as blow-off. Where low "sag" point occurs in a waterline, developer/contractor must either demonstrate that 6 ft. per second velocity can be attained through the low point by hydrant flushing from the nearest hydrant or, install a hydrant at the low point.

A hydrant to serve as a blow-off shall be installed at the termination of dead end mains including locations in cul-de-sacs.

### ***Air and Vacuum Relief Valve Assembly***

Combination air and vacuum relief valves shall be installed after an angle point where the vertical elevation change is more than one pipe diameter and as directed by the City Engineer. The tapped coupling shall be in a level section of pipe no closer than 18 inches to a bell, coupling, joint or fitting. Valves shall be installed in accordance with Standard Drawing W-8. Combination air and vacuum relief valves shall have cast iron bodies, stainless steel floats, and air & vacuum relief valves shall be as manufactured by APCO 143C or 14C or equal, installed in a vented galvanized steel cover.

### ***Pressure Reducing Station***

The materials and requirements for the installation of Pressure Reducing Station assemblies in vaults shall be designed and submitted to the City Engineer for approval. Some of the general design requirements for these installations shall include but not be limited to the following:

- a) Piping and valves including pressure reducing valve shall be not more than 2 inches in diameter smaller than the connecting pipelines. The PRV assembly shall include a low flow bypass that will flow one-fourth to one-third the capacity of the main PR valve.

- b) Vault shall not be deeper than 6 ft. from the floor to the top of the vault.
- c) Hatches shall be dual opening aluminum manufactured by Bilco Model JDAL for pedestrian rated and Model JDAL H20 for traffic rated. The open hatches must fully open to the walls of the vault. The hatches shall include a trough/channel frame with slamlocks, open compression springs, 304 stainless steel hardware with temper proof bolts and 304 stainless steel automatic hold open arm with red vinyl grip. Door channel drain shall be piped through curb face.
- d) A properly sized pressure relief valve shall discharge through a vented parkway culvert structure to the street gutter.
- e) Pressure reducing/sustaining valve assemblies shall be as manufactured by Cla-Val 926-01 with A, B, C, S and KC options
- f) Pressure relief valve shall be as manufactured by Cla-Val 50A-01 with A,B,C,S and KC options.
- g) Vault shall be located back of or within the sidewalk and drain by gravity.
- h) Vaults shall be piped with 4-inch Sch.40 PVC gravity drain to the nearest outlet with a minimum 1% slope on the pipe.

Pressure reducing station equipment and piping layout shall be per standard drawing W-9.

### ***Back-flow Prevention Devices***

Back-flow prevention devices shall be installed where required by the City Water Operations Division but shall be installed on all dedicated fire flow systems, all irrigation systems, and to existing or future Reclaimed (non-domestic) water systems. Installation shall comply with Standard Drawing W-10. Installations for two (2) inch and one (1) inch irrigation system connections shall be copper piping utilizing valves per Water Service Assembly Standard Drawings W-1 and W-2. The 2 inch and 1 inch Reduced Pressure Principal Back Flow Devices shall be as approved by the California Department of Health Services, Drinking Water Division. All back-flow devices shall be tested upon installation by an approved certified back-flow technician.

### ***Concrete***

Concrete mortar and related materials incorporated into construction shall comply in all respects with Section 201 of the Standard Specifications. Concrete shall be type V. Where reinforcing kinds and amounts are not shown in the Standard Drawings, or on the approved project plans, reinforcing design must be submitted and approved before construction can be started.

### ***Pre-cast Concrete Vaults and Access Hatches***

All precast sections shall be manufactured in a plant especially designed for the purpose, and all work shall be done under strict plant controlled supervision.

Design loads shall consist of dead load, live load, impact, and in addition, loads due to water table, and any other loads which may be imposed upon the structure.

Live loads shall be H-20 per A.A.S.H.T.O. Standard Specifications for Highway Bridges with revisions. Design wheel load shall be 16 kips. The live load shall be the loading which the maximum shears and bending moments in the structure.

All forms used in placing concrete shall be of metal and sufficiently designed and braced to maintain their alignment under pressure of the concrete during placing.

#### ***Concrete:***

- a) Aggregates: All aggregates fine and coarse, other than lightweight aggregate shall conform to specifications outlined by ASTM C-33-64. Lightweight aggregates fine and coarse shall conform to the specifications outlined by ASTM C-330-64T. Aggregates shall be free of deleterious substances causing reactivity with oxidized hydrogen sulfide. Both types of aggregate shall be graded in a manner so as to produce a homogeneous concrete mix. All materials are to be accurately weighed at the central batching facility for mixing.
- b) Cement: All cement shall be Portland Cement conforming to ASTM C150, Type II. Cement content shall be sufficient to produce minimum strength of 4,000 psi or other design strengths required.
- c) Placing; All concrete shall be handled from the mixer or transport vehicle to the place of final deposit in a continuous manner, as rapidly as practicable, and without segregation or loss of ingredients, until the approved unit operation is completed. Concrete shall be placed in layers not over two (2) feet deep. Each layer shall be compacted by mechanical internal or external-vibrating equipment. Duration of the vibration cycle shall be limited to the time necessary to produce satisfactory consolidation without causing objectionable segregation.



- d) Curing: For purposes of early reuse of forms, the concrete may be steam cured after an initial set has taken place. The steam temperature shall not exceed 160 degrees, and the temperature shall be raised from normal ambient temperatures at a rate not to exceed 40 degrees per hour.

The steam cured unit shall not be removed from the forms until sufficient strength is obtained for the unit to withstand any structural strain that may be subjected during the form stripping operation. After the stripping of forms further curing by means of water spraying or a membrane curing compound may be used, and shall be of a clear or white type, conforming to ASTM C 309-58.

All reinforcing steel, including welded wire mesh, shall be of the size and in the location as shown on the plans. All reinforcing shall be sufficiently tied to withstand any displacement during the pouring operation. All bars shall be immediate or hard grade billet steel conforming to ASTM A 15. Bars other than ¼-inch round, or smaller, shall be deformed in accordance with ASTM A 305.

Vault access hatches shall be aluminum, 2 door type. The hatches shall be hinged on the six-foot side. The hatches that are pedestrian rated and shall be Model Number JDAL manufactured by Bilco. The hatches shall include a trough/channel frame with slamlocks, open compression springs, 304 stainless steel hardware and bituminous paint. The hatch shall include heavy-duty 304 stainless steel hinges with tamper-proof bolts, and 304 stainless steel automatic hold open arm with red vinyl grip. A recessed padlock clasp with hinged cover shall also be provided. The traffic rated hatches shall be traffic rated for continuous H20 loading. The hatch shall be a Model JDAL H20 Manufactured by Bilco. The hatch shall include a trough/channel frame with slamlocks, open compression springs, 304 stainless steel hardware and bituminous paint. The hatch shall include heavy-duty 304 stainless steel hinges with tamper-proof bolts, and 304 stainless steel automatic hold open arm with red vinyl grip. The hatch cover shall be bolted to the frame to prevent vibration and damage due to traffic loading.

The Contractor shall prepare a hole large enough to accommodate the outside dimensions of the vault as shown on the Drawings. Prior to setting, the Contractor shall provide a minimum of 6-inches of ¾-inch rock base for the vault. The base material shall be compacted and graded level and a proper elevation to receive the vault in relation to the conduit grade and ground cover requirements as designated in the plans.

Delivery of the product will be made by common carrier or manufacturer's boom equipped truck, in which case the Contractor shall provide sufficient labor to assist the carrier in placing the unit.

Sealants between the vault joints shall be permanently adhesive flexible plastic material complying with Federal Specification SS-S-00210 (GSA-PSS).

Consideration will be given to substitution of vaults constructed cast in place. Structural calculations evidencing the adequacy of the strength and integrity for the purpose intended shall be submitted for approval.

## **2. SEWERAGE SYSTEM**

### ***Pipe***

Sewer main pipe material shall be extra strength Vitriified Clay Pipe (VCP) or Heavy Wall Poly Vinyl Chloride PVC (SDR26) with locked-in O Ring per ASTM D3034. PVC (SDR 35) is approved for use as house sewer lateral.

(VCP) shall meet the requirements of the Standard Specifications Section 207-8. VCP pipe joints shall be "Type G" and shall meet requirements of Section 208-2.3 of the Standard Specifications. "Type D" joints shall only be allowed for repairs.

Polyvinyl Chloride (PVC) Pipe shall meet the requirements of the Standard Specifications Section 207-17 EXCEPT that wall thickness minimum shall be SDR 26.

Ductile Iron Pipe (D.I.P.) shall not be used in the sewerage system except in locations where in the opinion of the City Engineer, VCP or PVC pipe would not be suitable. D.I.P., if used, shall comply with Standard Specification Section 207-9.1 through Section 207-9.2.6. Pipe shall be thickness Class 22 Tyton joint pipe with 40 mils polyurethane lining or approved equal. Pipe shall be polyurethane encased per ANSI/AWWA A21.5/C105.

### ***Bolts and Nuts***

All bolts, nuts, and washers shall be 316 stainless steel and torqued to manufacturer's specifications.

### ***Concrete***

Concrete mortar and related materials incorporated into construction shall comply in all respects with Section 201 of the Standard Specifications. Cement shall be type

V. Where reinforcing kinds and amounts are not shown in the Standard Drawings, or on the approved project plans, reinforcing design must be submitted before construction can be started.

### ***Pre-cast Concrete Manholes***

Pre-cast concrete manholes shall comply with ASTM C 478.

Minimum allowable steel shall be No. 4 bars cast into each unit.

Manhole components shall be designed for H-20 highway loads.

Pre-cast concrete manhole risers and tops shall be constructed of Class 560-C-3250, Type V cement per Standard Specifications, Section 201.1.

Manholes shall be fabricated only from eccentric taper sections and standard cylinder units of the proper internal diameter.

The minimum nominal shell thickness for formed and vibrated sections shall be 1/8 of the internal diameter of the riser or largest cone diameter.

Grade rings shall be the size and quantity as indicated in the Standard Details. Grade rings shall be free from cracks, chips or excessive roughness as determined by the Inspector.

Steps shall be steel reinforced polypropylene. Lane Poly Steps Model 14850 or approved equal. Steps shall be 13" wide and on 12-inch vertical centers. Steps shall meet the requirements of ASTM C 478 and AASHTOM-199. Polypropylene shall conform to ASTM D 4101. Reinforcing deformed bars shall be 1/2 inch. Grade 60 meeting ASTM A615. Holes (1" dia 3-1/2" deep) may be cast in the plant or drilled in the field. Install exactly as per manufacturer's recommendations.

### ***Sealing of Pre-cast Manhole Sections***

Sealing of pre-cast manhole sections shall utilize one of the following methods:

a) Cement-Mortar Grout

Grout for watertight joints between pre-cast sections shall be composed of one part Portland cement to two parts of clean well-graded sand of such size that all pass a No. 8 sieve. Cement, aggregate, and water for mortar shall conform to the applicable provisions of the Concrete Technical Specifications.

b) Epoxy Grout

Epoxy grout shall be used in repairing manhole and manhole base surfaces. Epoxy grout shall be made with epoxy and sand. The sand shall be clean,

bagged, graded, and kiln dried silica sand. The prepared grout shall wet the contact surface and provide proper adhesion, or a coat of epoxy shall be applied prior to placing the epoxy grout. The epoxy bonding compound shall be as specified in the Concrete Technical Specifications.

c) Plastic Joint Sealing Compound

Preformed cold-applied ready-to-use plastic joint sealing compound shall be Quick-Seal as supplied by Associated Concrete Products, Santa Ana, California or approved equal.

***Manhole Frames and Covers***

- a) Manhole frame and covers shall be Model No. A-1499 for 4-ft. diameter manholes and model A-1493 for 5-ft. diameter manholes as manufactured by Alhambra Foundry or approved equal. Bolt down water tight covers and rings shall be Alhambra model 1254B6 or approved equal. Frames and covers sets shall be designed for H-20 loading and complies with State of California Standard U-45. All castings shall conform to ASTM Specification A-48, Class 35B Iron. Certified documentation shall be submitted at the time of delivery of frames and covers to job site.
- b) The bearing surfaces of the frames and covers shall be machine ground and the cover shall seat firmly into the frame without rocking. Frame and covers shall be matched marked in sets before shipping to job site and shall be installed as match sets only.
- c) Covers for use on sewer structures shall bear the letter "S" in the center of the cover. All letters shall be 2 ¼ inches high.
- d) The inside diameter of the frame where the cover rests shall not vary more than 1/16-inch. The outside radius of the cover shall not vary more than 1/32-inch.
- e) Testing of frame and covers shall consist of a Proof of Load Test. The Proof Load for testing is 49,700lbs. The load shall be concentrated on a 9-inch by 9-inch by 1- inch minimum thickness steel plate placed on a ¼-inch rubber pad centered on the assembled frame and cover set. The specified load shall be applied by a calibrated testing machine and held for a period of 1 minute. Upon removal of the load, the test specimens shall be examined for cracks and permanent deformation. Any cracks or deformation shall be cause for rejection.
- f) Before leaving the foundry, castings shall be cleaned and subjected to a hammer inspection. Castings shall then be dipped twice in a preparation of asphalt or coal tar and oil applied at a temperature of not less than 290°F, nor more than 310°F, and in such a manner as to form a firm and tenacious coating.
- g) The City shall select frames and covers delivered to the job site for proof load testing. The City shall be notified and may be present during proof load testing.

Testing shall be done at testing facility approved by the engineer at the contractor's expense. Failure of any selected specimen/s will result in rejection of the delivered lot. The manufacturer of the rejected frames and covers shall be considered "non-compliant".

### ***Interior Liner/Coating***

- a) Lining system shall be applied to the interior concrete surface of new manholes.
- b) Surface preparation is not required on clean concrete surfaces free from curing compounds, oils, or other foreign substances. Surface cleaning, if required, shall be performed as recommended by the lining manufacturer.
- c) Application - The two-component lining system shall be applied only by workers approved by the manufacturer and have appropriate training and experience with the specified material. The lining shall be applied in high pressure airless equipment approved by the lining manufacturer. The equipment shall be in good working order to insure correct proportioning and mixing of the components.

A minimum thickness of 3 mils of epoxy shall be applied as the primer coat.

A minimum thickness of 80 mils of polyurethane shall be applied prior to the epoxy becoming tack free.

The Contractor shall take wet gauge thickness readings as required during lining application to insure correct lining thickness.

The uniform lining shall be free from porosity, without bubbles or pinholes and uniform in color. All areas of question shall be removed, reworked and patched to the satisfaction of the Engineer. Before final acceptance, in the presence of the City Inspector, the Contractor shall test with a high voltage holiday or porosity tester and repair/patch any pinholes.

Application of the lining shall not take place during rain, fog or high winds.

- d) Material shall be a two-component, 100% solid, non-solvent hybrid polyurethane coating, with a shore "D" hardness of 57 at 77 degrees Fahrenheit. The material shall be a high-build type capable of application thickness, as specified, without runs or sags and shall be capable of passing ASTM-D-1737 for flexibility, using cylinder mandrel of 0.5" (12.7mm). The flash point of the fluid mixture shall be 450 degrees Fahrenheit open Zahn cup.

The coating material shall meet or exceed the requirements of 500-2.4.6 through 500-2.4.10 of the Standard Specifications.

The color shall be white or cream. The complete coating shall be impermeable to sewer gases and liquids and nonconductive to bacterial or fungus growth. The lining shall be capable of repair at any time during its life.

Warranty – The Lining system shall be warranted for five (5) years against any type of defect. Contractor shall remove and replace all defects at his expense during the warranty period.

### ***Exterior Waterproofing***

- a) Coating system shall be applied to the exterior surface of all new manholes.
- d) Surface preparation is not required on clean concrete surfaces free from loose concrete, mud, dirt, oils or other foreign substances. Surface cleaning, if required, shall be performed as recommended by the lining manufacturer.
- b) Application shall not proceed until surface is thoroughly dry. Material may be applied by brush, roller, heavy duty conventional or airless spray. Application shall be according to manufacturer's recommendations.
- c) Material shall be KOP-COAT: Bitumastic No. 300-M, which is a two-component, self-priming, chemically cured catalyzed coal tar epoxy. Primers, thinners and cleaners shall be as recommended by Carboline Company manufacturers of this coating material. 300-M shall be applied in two coats for a minimum total thickness of 16 dry mils. Consult Carboline Company for wet mil application rates.

### ***3. PIPE CASING***

Steel casing pipe for water or sewer mains shall be made from new and welded steel sheets conforming to ASTM A245, commercial grade, or of plate conforming to ASTM A283. Casing shall be furnished and installed per Standard Drawing WS-3. All field joints shall also be butt welded full circumference or by other means approved by the City Engineer or his designee. Use of a jacking band to reinforce the end of the pipe receiving the jacking thrust will be required. The minimum size and thickness of casing pipes for insertion of various sizes or DIP water or sewer mains shall be as follows, unless a larger or heavier wall casing pipe is required by the agency having jurisdiction other than San Clemente.

## **SECTION IV - INSTALLATION REQUIREMENTS**

### **1. GENERAL**

#### ***Samples, Tests and Defective Material***

At the option of the City Engineer or his designee or Inspector, the source of supply of each of the materials shall be approved before delivery is started and before such material is used in the work.

All tests of materials furnished by the Contractor shall be made in accordance with the commonly recognized standards of national technical organizations, and such special methods and tests as are prescribed in these specifications.

The Contractor shall furnish the City a certified copy of all factory and mill assembly test reports. Materials shipped by the Contractor from a factory or mill before having satisfactorily passed such testing and inspection shall not be incorporated in the work.

The Contractor shall furnish and deliver to the laboratory such samples of materials as are requested by the City Engineer or his designee. Samples will be secured and tested whenever necessary to determine compliance with the specifications. All testing expenses are to be paid by the Contractor.

Materials not conforming to these specifications shall be considered defective. Such materials shall be removed immediately from the site of the work. Rejected material, the defects of which have been subsequently corrected, shall not be used until approved in writing by the City Engineer or his designee.

#### ***Pipe Bedding, Trench Backfill and Roadway Repair***

Pipe bedding, trench backfill and roadway repair will comply with requirements of Standard Drawing WS-1. Any conditions/requirements placed as part of City issued permit(s), will supplement the standard drawing. Magnetic locator tape shall be installed one foot above all non-metal sewer and water pipelines per Standard Drawing WS-1.

Contractor's failure to comply with Standard Specifications, Section 306-1.1.6 entitled "Bracing Excavations", is cause for stopping the work until compliance is met.



The City is in the process of rehabilitating and resurfacing most streets and many streets will not be allowed to be open cut. Refer to the "Conditions for Trench Cut Permits".

The Contractor shall provide and maintain at all times during construction, means and devices with which to promptly remove and properly dispose of all water from any source entering the excavations or other parts of the work.

### ***Overexcavation***

If excessively wet, soft, spongy, unstable, or similarly unsuitable material is encountered at the surface upon which the bedding material is to be placed, the unsuitable material shall be removed to a depth as determined in the field by the Engineer and replaced with suitable approved granular material.

### ***Earthwork***

All excavations and embankments required to complete the work as specified herein shall be made to the lines and grades shown upon the plans and survey staked in the field. Excavated materials not required for fill, embankments, or backfill, in the opinion of the City Inspector, shall be disposed of or removed by the Contractor from the site of work.

All excavations shall be performed, protected, and supported as required for safety and in the manner set forth in the operation rules, orders, and regulations prescribed by the Division of Industrial Safety of the State of California. Work not conforming to these standards, will be stopped by the City Engineer or his representative. Barriers shall be placed at each end of all excavations and at such places as may be necessary along excavations to warn all pedestrians and vehicular traffic of such excavations. Barricades with lights shall also be placed along excavations from sunset each day to sunrise of the next day until such excavation is entirely back-filled.

No excavation material shall be deposited on private property unless written permission from the owner is secured by the Contractor. Copies of said written permission, duly signed by the owners of the private property involved, shall be furnished the City by the Contractor before any excavated material is placed outside the limits of the established right-of-way. Free access must be provided to all driveways, water valves, hydrants, or other property or facilities that may have routine use.

### ***Protection/Reconstruction of Survey Monuments***

The California Land Surveyors' Act (CSLA) requires that all survey monuments shall be protected and perpetuated. The CSLA also specifically requires that when monuments are disturbed by the reconstruction of streets, highways, or any other public works they, (the monuments), shall be reset in the surface of the new construction. Resurfacing of streets and highways resulting in monuments being covered with paving material instead of being preserved is a violation of the Land Surveyors' Act. The Contractor shall retain a California licensed land surveyor for preservation of survey monuments.

### ***Railroad Crossing***

The railroad right-of-way in proximity to the beach is owned by the Orange County Transportation Agency (OCTA) and maintained by the Southern California Railroad Agency (SCRRA). Metrolink is a contract operator. The Contractor shall perform the work for the installation of water and sewer lines under railroad tracks and across railroad right-of-way in accordance with the directions and under the supervision of the railroad company on whose property the work is done. It shall be the Contractor's responsibility to secure all necessary permits from OCTA/SCRRA for start and prosecution of construction work on railroad property and right-of-way.

### ***Blasting***

Blasting for excavation will not be permitted in San Clemente.

### ***Abandonment of Pipes and Appurtenances***

Existing pipes, when required by the plans or specifications, shall be removed from service by one of the following methods as determined by the City Engineer or his designee:

Pipe 4-inch and smaller may be cut and plugged with concrete at intervals not longer than 100 ft.

Pipe 6-inch and larger shall be; a) removed from the ground, in which case all backfill and repair of surface shall be in accordance with applicable portions of these specifications or, b) completely filled with 2 sack/cu.yd. slurry by pumping. Removed pipe shall be legally disposed by the Contractor.

### ***Restoration and Cleanup***

The Contractor shall restore or replace all removed or damaged paving, curbing, sidewalks, gutters, trees, shrubbery, fences, sod, or other disturbed surfaces or

structures to a condition equal or better than existed before the work began. The Contractor shall evidence pre-project condition with video. Failure to document pre-project conditions permits the City Inspector to dictate the extent of restored repair required.

### ***Record Drawings***

Prior to Final Acceptance the Contractor shall furnish the City Mylar Drawing Reproducibles and drawings in digital format showing all revisions from the original approved plans. Record drawings must have an appropriate registered engineer stamp to be acceptable. Applicable data, manuals, warranties, maintenance schedules, etc., must be delivered to the City prior to acceptance and operation is take-over by City staff.

## **2. WATER SYSTEM**

### ***Cut Sheets from Surveyor***

No work shall commence prior to preparation of water line cut sheets and duplicate copies supplied to the inspector. The cut sheets shall be prepared only by a licensed Land Surveyor or Civil Engineer. This requirement may be waived at the discretion of the City Engineer, if street curb and gutter installation is in place.

### ***Pipe***

Pipelines shall be installed in accordance with the City Standards, AWWA Standards, and Section 306 of Standard Specifications as applicable. Typical trench section shall be in accordance with the standard drawing WS-1.

### ***Tracer Wires for Non-Metallic Pipelines:***

Copper tracer wire shall be installed with all non-metallic pipelines just below the horizontal centerline of the pipe, for the purpose of providing a continuous signal path for electronic pipe locators used to determine pipe alignment after installation. The copper wire shall be #12 Cu., with HMWPE insulation. The wire shall be electrically continuous throughout the entire piping system including adjacent fire hydrant assemblies. At hydrants, the wire shall be extended up the bury and secured by a cable lug under the top nut of one set of breakaway bolts. At cul-de-sacs, the wire shall be placed in the same trench with the last long side service lateral and extended into the meter box. All splices shall be wrapped with PVC tape and the wire shall be tied to the pipe at 20-foot intervals with plastic adhesive tape. The Contractor will perform an electrical continuity test at his expense.

## **Valves**

Unless otherwise indicated on the plans, all valves shall be buried. Geared valves shall be set in valve vaults or manholes. The operating nut on a buried valve shall be readily accessible for operation through a valve box. Valve boxes shall be set vertically to finish grade. Valve stem extensions are to be provided as specified per the Standard Drawing W-4. All valve locations shall be marked by a 2-inch "V" and offset distance in feet "chiseled" in the curb face.

All valves shall be anchored in concrete as specified by Standard Drawing W-4. The anchor shall bear against undisturbed ground. In unstable conditions, the bearing surface shall be as directed by the City Engineer or his designee. Valve boxes shall be firmly supported and shall be kept centered and plumb over the wrench nut of the valve; the box cover shall be flush with the surface of the finished pavement.

## **Hydrants**

Fire hydrant assemblies shall be furnished and installed in accordance with Standard Drawing W-3 and as specified herein, and shall include the connection to the main, the fire hydrant, hydrant bury, valve, valve well and box, connecting piping, concrete thrust blocks, and appurtenances as shown in Standard Drawing W-3.

Fire hydrant assemblies shall be located as shown on the plans, as staked in the field, or as approved by the City Inspector. The center of the fire hydrant shall be, except as otherwise approved by the City Inspector, located as follows:

- a) Where concrete curbs and sidewalks exist or are to be constructed, and the sidewalk is next to the property line; behind the sidewalk at the property line.
- b) Where there are no curbs or sidewalks, the location shall be designated on the detailed plans and subject to approval of the City Engineer or his designee.

## **Tapping Sleeves**

Tapping sleeves shall be 316 stainless steel wrap around type and shall be assembled in accordance with the manufacturer's instructions and to the satisfaction of the City Engineer. The pipe barrel shall be thoroughly cleaned with a wire brush to provide a smooth, hard surface for the sleeve. The sleeve shall be supported, independently of the pipe during the tapping operation and must be pressure tested before tapping, in the presence of the City Inspector, as described herein. Thrust blocks shall be provided as with any other fitting. The tapped line shall be at least 4" greater in diameter than the attached line; i.e., a 6-inch onto a 10-inch unless

specifically authorized by the City Engineer. All other sizes will require installation of a correctly sized ductile iron tee.

### ***Service Laterals, Chlorination Assemblies, and Combination Air Relief Valve Connections***

Service laterals, air and vacuum relief valve connections shall be installed in accordance with the applicable plans and Standard Drawings W-1, W-2, & W-8.

Some slack shall be made in the water tube to provide for flexibility in the event of a load due to settlement, expansion, or contraction. A minimum cover of 24" and a maximum cover of 30" shall be provided below the finished street grade.

### ***Concrete Thrust Blocking***

Anchors and thrust blocks shall be constructed in accordance with Standard Drawing W6 and where shown on the drawings and as specified in the manufacturer's pipe instruction manual, or where directed by the City Inspector and as specified herein. In general, thrust blocks and anchors will be placed at all angle points, hydrant ells, and at valves. The concrete used for thrust and anchor blocks shall be Type V Class 660-C-3750. Medium and high pressure pipe operating at pressure greater than 200 psi shall have civil engineer stamped drawings for detail design.

### ***Connections to Existing Water Mains***

All connections shall be made by the Contractor unless otherwise shown on the plans or specified herein. The Contractor shall give the City a minimum of two (2) working days notice before the time of any requested shutdown of existing mains or services. The Contractor shall post turn-off notices on all affected services 24 hrs. prior to the turn-off. Turn-off notice forms will be provided by the City. Connections shall be made only in the presence of the City Inspector, and no connection work shall proceed until the City has given notice to proceed. The Contractor shall furnish all pipe and materials including furnishing all labor and equipment necessary to make the connections, all required excavation, backfill, pavement replacement, lights, and barricades, and he may be required to include a water truck, highline hose, and fittings as part of his equipment for making the connections. In addition, he shall assist the City in alleviating any customer hardships incurred during the shutdown. Standby equipment or materials may be required by the City Inspector. Where connections are made to existing valves, the Contractor shall furnish and install all temporary blocking, steel clamps, shackles, and anchors as required, and he shall replace the valve well (box) and cover and adjust the valve cover to the proper grade. The existing valves will only be operated by City personnel. The

Contractor will de-water existing mains, as required, in the presence of the City Inspector. All valves, existing or newly installed, shall be readily accessible at all times to the City Inspector for emergency operation.

The City Inspector may postpone or reschedule any shutdown operation if for any reason he feels that the Contractor is improperly prepared with competent personnel, equipment, or materials to proceed with the connection work. If progress is inadequate during the connection operations to complete the connection in the time specified, the City Inspector shall order necessary corrective measures. All costs for corrective measures shall be paid by the Contractor.

The Contractor shall be responsible for determining in advance, the grade (elevation) of all existing pipelines to which connections are to be made. Connections shall be made with as little change as possible in the grade of the new main. If the grade of the existing pipe is below that of the new pipeline, a sufficient length of the new line shall be deepened so as to prevent the creation of any high spot or abrupt changes in grade of the new line. Where the grade of the existing pipe is above that of the new pipeline, the new line shall be laid at specified depth, except for the first joint adjacent to the connection, which shall be deflected as necessary to meet the grade of the existing pipe. If sufficient change in direction cannot be obtained by the limited deflection of the first joint, a fitting of the proper angle shall be installed. Where the connection creates a high or low spot in the line, a standard air relief or blow-off assembly shall be installed as directed by the City Inspector.

In no event shall the new pipelines be connected to existing facilities until the new pipelines have been successfully pressure-tested and disinfected. The City does not warranty the condition of existing facilities. It is the Contractor's sole responsibility to provide acceptable pressure testing of his new installation.

### ***Disinfection of Water Mains and Services***

All water mains, water services, attached appurtenances, and connections, if any, shall be disinfected in accordance with AWWA C651-92 and as specified herein.

The standard type of chlorine to be used is elemental liquid feed through a chlorinator as a gas. Small sections of pipe may be chlorinated with Sodium or Calcium Hypochlorite in accordance with AWWA C651-92. Submit a chlorination plan if liquid  $Cl_2$  is not to be used. The basic disinfection procedure consists of:

1. Preventing contaminating materials from entering the water main during storage, construction, or repair.
2. Removing, by flushing or other means, those materials that may have entered the water main.

3. Chlorinating any residual contamination that may remain, and flushing the chlorinated water from the main.
4. Protecting the existing distribution system from back-flow due to hydrostatic pressure test and disinfection procedures.
5. Determining the bacteriological quality by laboratory test after disinfection.
6. Final connection of the approved new water main to the active distribution system.

Before being placed in service, all facilities shall be chlorinated and certified. Chlorine shall be applied by direct chlorine gas feed.

The chlorinating agent shall be applied at the beginning of the section to be chlorinated and shall be injected through a corporation stop, a hydrant, or other approved connection to ensure treatment of the entire system being disinfected. All required corporation stops and other plumbing materials necessary for chlorination or flushing of the main shall be installed by and at the expense of the Contractor.

Water shall be fed slowly into the pipeline with chlorine applied in amounts to produce a dosage of not less than 50 ppm nor more than 100 ppm in all sections of the pipeline and appurtenances. Treated water shall be retained in the system for a minimum of 24 hours and shall produce a chlorine residual at the end of the retention period of not less than 35 ppm in all sections being disinfected.

The Contractor shall furnish all equipment in good operating condition, labor and material, and water necessary for chlorinating and flushing the pipeline and for certification of the pipeline disinfection.

During the chlorination process, all valves and facilities shall be operated.

Disinfecting the mains and appurtenances, hydrostatic testing, and preliminary retention may run concurrently for the required 24-hour period, but in the event there is leakage and repairs are necessary, additional disinfection shall be made by injection of chlorine solution into the line as provided herein.

In the event groundwater is encountered and it is impossible to prevent its entrance into the mains, or the mains are not free from dirt, they shall be thoroughly flushed prior to disinfection. After the required period of retention of the chlorine gas solution, a certified testing laboratory will test the water for residual chlorine and will make any additional test that may be necessary.

If the tests are not satisfactory, the Contractor shall provide additional disinfection as required. If the requirement for additional disinfection is due to any omission, negligence, or nonconformance with these specifications on the part of the

Contractor, or because of repairs made to the pipeline after its initial filling with water for disinfection, the Contractor shall provide such additional chlorination at his expense.

Every service connection served by a main being disinfected shall be tightly shut off at the curb stop before water is turned into the main. Care shall be taken to expel all air from the main and services during the filling operation.

After chlorination, the water shall be flushed from the line at its extremities until the replacement water laboratory tests are equal chemically and bacteriologically to those of the permanent source of supply.

The chlorinated water shall be disposed by the Contractor. The City will not be responsible for loss or damage resulting from such disposal. Chlorine shall not be stored or left unattended on the job site at any time. The Contractor shall maintain, on the job site, necessary emergency chlorine cylinder repair equipment during the chlorination process and provide personnel trained in its use. The water used shall be metered and billed to the Contractor accordingly.

### ***Leakage Testing***

Pipelines shall be subjected to a field hydrostatic pressure of 200 psi for a period of 4 hours. In testing down-sloping pipeline, 200 psi pressure shall be applied at the end of the lower elevation unless otherwise directed. Before testing, the pipe trench shall be back-filled with 2-1/2 feet of material. Water necessary to maintain 200 psi shall be measured through a meter. The leakage shall be considered as the amount of water entering the pipe during the test, less the measured leakage through valves and fittings. Any noticeable leaks shall be stopped, and any defective pipe shall be replaced with new sections.

Tests shall be made before connecting the new line with the existing City pipes and mains. The test shall further be conducted with valves open, and the open ends of pipes, valves and fittings suitably closed. Valves shall be operated during the test period. Testing against water valves is prohibited.

Testing of new water main facilities shall be done by a State certified water testing laboratory who shall provide certified testing results.

Concrete anchor and thrust blocks shall be allowed to cure a minimum of 24 hours before testing the system. All labor, materials, tools, and equipment for testing shall be furnished by the Contractor.



Field Testing Procedure: The test shall be conducted in the following manner. All air shall be expelled from the pipe. If air valves or hydrants or other outlets are not available, taps shall be made at high points to expel air. These taps shall be tightly plugged after the test. The average water velocity when filling a pipeline should be less than 1 fps and should not exceed 2 fps. The gallons per minute fill rate for 1 fps is determined by squaring the pipe radius in inches and multiplying by 10. Thus  $Q_{fill}$  for 1fps in an 8-inch pipe is equal to 4 squared x 10 = 160 gpm

Leakage in a 4-hour test shall not exceed the amount calculated using the following formula.

$$V_{allowable} = \frac{LD (P)^{\frac{1}{2}}}{133,200}$$

Where  $V_{allowable}$  = Total volume (in gallons) (per 4 hours) pumped into system to maintain pressure P

L = feet of waterline

D = diameter of pipe in inches

P = pressure in pounds per square inch

Example: The maximum allowable volume pumped in 4 hours to maintain pressure P (200 psi) in 1000 feet of 8 inch pipe equals:

$$V_{allowable} = \frac{1000 \times 8 \times (200)^{\frac{1}{2}}}{133,200}$$

$$V_{allowable} = 0.85 \text{ gallons}$$

Acceptance of the system requires a certification signed by the contractor and the inspector that the leakage allowance was not exceeded.

### **3. SEWERAGE SYSTEM**

#### ***Safety Requirements***

Contractor shall comply with Section 7-10 of the Standard Specification. Particular attention is directed to Section 7-10.4.4 Confined Spaces as it applies to "Confined Space Entry Program".

### ***Inspection***

The principal items of work for which inspection is required but not limited to is as follows.

- a. Traffic plan and control
- b. Surveying
- c. Clearing and grubbing or pavement removal
- d. Trenching and shoring
- e. Pipe bedding
- f. Pipe laying
- g. Construction of structures
- h. Video taping of all constructed sewers
- i. Placing and compacting of backfill
- j. Cleaning of sewers and mandrel test of PVC sewer
- k. Air testing of sewer
- l. Paving or grading over trench
- m. Raising manhole covers to grade
- n. Preparation in and conduct of Final Inspection

### ***Cut Sheets from Surveyor***

No work shall commence prior to the preparation of the sewer line cut sheets and duplicate copies supplied to the Inspector. The cut sheets shall be prepared only by a licensed land surveyor or civil engineer. The cut sheets shall include the location of wyes, house laterals at the property line and manhole rim elevations by sewer stationing. House lateral stakes shall be marked to indicate cut, sewer stationing and lot number.

### ***Scope of Inspection***

All work shall be left open and uncovered until the installation is approved by the City Inspector. The Contractor shall not proceed with any phase of work until the previous phase has been inspected and approved by the City. At such time as the Contractor's work force on the sewer becomes less than a full day's activity, it shall be the Contractor's responsibility to notify the City Inspector, on a daily basis, of the work requiring inspection.

Inspection shall be made at the following intervals of work:

- a. Trench excavation and bedding.
- b. Placing of pipe, fittings and structures.
- c. Saddle or manhole connections to existing sewers. (See Section 3-10.)
- d. Placing and compacting of the pipe zone backfill and placement of magnetic locator tape.

- e. Backfill in and pavement repair of balance of trench to grade in public right-of-way.
- f. Cleaning, mandrel testing of PVC pipe, air testing and mirroring. (after receipt of compaction certification by the City Inspector and prior to paving.).
- g. Repairs made after initial inspection.
- h. After manholes are raised to grade and prior to sewer put into service. (Final inspection).

The City shall at all times have access to work during construction and shall be furnished with every reasonable facility for ascertaining full knowledge respecting the progress, workmanship and character of materials used and employed in the work.

No pipe, fittings or other materials shall be installed until inspected and approved by the City or its representative. All installations that are to be back-filled shall be inspected and approved by the City prior to back-filling, and the Contractor shall give due notice in advance of back-filling to the City Engineer so that proper inspection may be provided.

### ***Pipe***

Installation shall comply with section 306 of Standard Specification for material and joining pipes. Typical trench section shall be in accordance with Standard Drawing WS-1. Main line PVC pipe sewers shall be tested by pulling a mandrel through the pipe with only manual force applied. The mandrel cross section diameter shall be at least 95% of the unloaded inside diameter of the sewer. Contractor shall furnish all material, equipment and labor for the test.

### ***House Laterals***

The Contractor shall install house laterals and wye or tee branch fittings of the size and location as indicated on the plans. The Contractor shall not proceed with placement of the house laterals until a surveyor has staked the laterals at sewer center and property lines.

No bends greater than one-eighth shall be used in the construction of house laterals within the public right-of-way. Laterals shall be joined to wye branch fittings at the sewer main by the use of eighth bends positioned to obtain the desired lateral slope. All fittings or laterals that are to be left unconnected shall be plugged with a vitrified clay or neoprene stopper.

### ***Connection to Existing Sewers***

Connection of sewer laterals to Existing Sewer mains shall be installed per Standard Drawing S-8.

### ***Manholes***

Manholes shall provide unrestricted linear flow. The concrete base shall be shaped with a wood float and shall receive a hard steel trowel finish prior to the concrete setting. In the event additional mortar is required after initial set has taken place, the surface to receive the mortar shall be primed, and the mortar mixed with an approved adhesive in the amounts and proportions as recommended by the manufacturer and as directed by the Inspector in order to secure as chip-proof a result as possible. The bases shall be set a minimum of twelve (12) hours before the manhole construction is continued. In certain critical situations, the time of setting may be reduced upon approval of the Engineer.

Manhole shafts and grade rings shall be joined with a minimum thickness of one-half (1/2) inch of cement mortar or approved sealer to form a watertight and smooth joint. Any infiltration of ground water shall be stopped by a repair approved by the Engineer.

Whenever new manholes are constructed in unpaved areas, the manhole cover shall be set eighteen (18) inches above finish grade, or as directed by the Inspector.

The Contractor shall place one-half (1/2) inch plywood inserts on the manhole shelf to prevent debris from entering the sewer in the event the manhole protection cover at the surface is disturbed.

The Contractor, while excavating in the vicinity of the existing sewer, shall use extreme care to prevent damage to the sewer pipe. The base shall be poured in place against undisturbed soil with Type V cement 560-C-3250 concrete. Manhole stubs shall be provided on both sides of the main and shall be rechecked for alignment and grade before concrete has set. Manhole stubs shall be plugged with brick and mortar prior to connecting the incoming sewer. The plug shall not be removed until the off-site work has been completed and the sewer cleaned.

Sewer manholes shall be constructed in accordance with the Standard Drawings and at the locations shown on the plans. The manholes shall be constructed of pre-cast concrete manhole units. Manhole cones shall be set with the straight side upstream.

Manhole stubs and sewer main shall be set before the concrete is placed. The various inlets and outlets to the manhole shall be located as indicated on the plans and as detailed in the Standard Drawings. Invert transitions shall be smooth.

***Videotaping***

Completed sewers shall be videotaped prior to final asphalt cap of the street section to avoid cutting or excavating of the new street. Videotapes shall be submitted to the City Engineer for review and acceptance. Sections of the sewer requiring corrections require re-taping. Final tapes become the property of the City.

***Sewer Line Air Test***

All sewers shall be air tested. Testing shall take place only after certification that the compaction requirements and sewer cleaning requirements have been met. Any re-compaction over the sewer or repair of the sewer shall invalidate previous testing in the section of pipe involved.

Each section of pipe, between two successive manholes, shall be tested by plugging all pipe outlets with suitable test plugs. Air shall be slowly added until the internal pressure is raised to 4.0 psig. The compressor used to add air shall have a pressure relief valve set at 5 psig to assure that at no time the pressure becomes greater than 5 psig. A pressure of 4 psig shall be maintained for at least three minutes to allow air temperature to stabilize. After the three-minute stabilization period, the air supply shall be disconnected and the pressure allowed to decrease to 3.5 psig. The time required for the air pressure to drop from 3.5 psig to 2.5 psig shall be measured and compared to the times shown below:

<u>Pipe Size</u>	<u>Time</u>
8 inch	4 minutes
10 inch	5 minutes
12 inch	6 minutes
15 inch	7 minutes
18 inch	9 minutes
21 inch	10 minutes
24 inch	11 minutes

If the pressure drop from 3.5 psig to 2.5 psig occurs in less time than the above values, the test has failed and the pipe shall be repaired and, if necessary, replaced or re-laid until the joints and the pipeline passes this test.

### ***Manhole Testing***

Manholes shall be watertight. All leaks shall be repaired as determined by the Engineer. Manhole water tightness test shall be performed, if required, by the inspector.

The manhole shall be filled with water to an elevation of one foot below the start of the cone section, but to a maximum depth of twenty (20) feet. The water shall stand in the manhole for a minimum of one (1) hour to allow the concrete to reach maximum absorption. After one (1) hour, the Contractor shall refill the manhole to the original depth and the drop in water surface shall be recorded after a period of two (2) minutes for each foot of water depth. The maximum allowable drop in water surface, for the period of testing, shall be one-half (1/2) inch for each fifteen (15) minutes of testing. Repairs shall be made as directed by the Engineer whenever leakage exceeds the limits as indicated above.

## **SECTION V – STANDARD DRAWINGS**

### ***WATER STANDARD DRAWINGS***

W-1	1-Inch Water Service Assembly
W-2	2-Inch Water Service Assembly
W-3	Fire Hydrant Assembly
W-4	Valve & Valve Box Assembly
W-5	Tapping Sleeve and Valve Box Assembly
W-6	Thrust Blocks & Temporary Blow-Off / Chlorination Assembly
W-7	Thrust Block Details (Vertical)
W-8	Air & Vacuum Relief Valve Assembly
W-9	Pressure Reducing Station
W-10	Backflow Preventer Assembly (Dual Check Valve w/Detector)
W-11	Pipe Separation: New Water Mains From Sewer or Non-Domestic Water Mains
W-12	Fire Hydrant Barricades
W-13	3", 4", 6" 8", & 10" Meter Installation
W-14	Waterline Header Installation

### ***SEWER STANDARD DRAWINGS***

S-1	Pipe Separation: New Sewers From Non-Domestic Water Mains or Domestic Water Mains
S-2	Standard Manhole
S-3	Manhole Base Plan
S-4	Standard Manhole Frame & Cover
S-5	Drop Connection to Standard Manhole
S-6	House Lateral Connection
S-7	Pipe Support of Perpendicular Crossing
S-8	Sewer Saddle Wye & Cut-In Wye Connection for Sewer Laterals
S-9	Clean Out Detail

## ***OTHER STANDARD DRAWINGS***

- WS-1 Pipe Bedding Trench Backfill and Roadway Repair
- WS-2 Anchor Block for Pipes Installed in Slopes Greater Than 30%
- WS-3 Pipe Casing



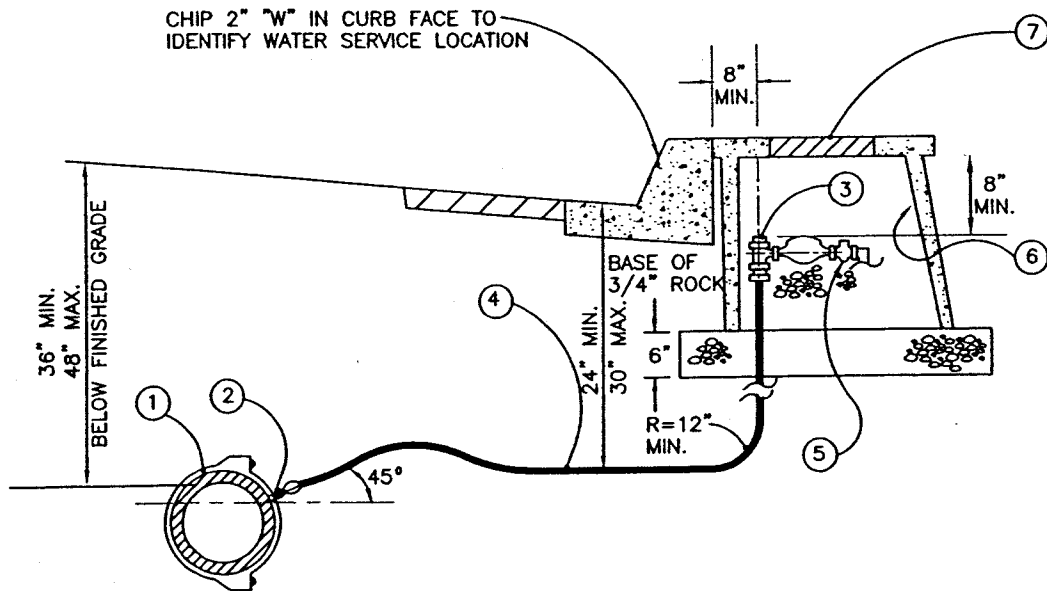

**NOTES:**

1. INSTALL CORPORATION STOP WITH KEY SIDEWAYS IN OPEN POSITION.
2. WATER SERVICE LINES SHALL BE INSTALLED PERPENDICULAR TO THE CENTERLINE OF THE STREET EXCEPT IN CUL-DE-SAC ENDS.
3. METER FITTINGS TO BE SAME SIZE AS SERVICE LINE.
4. METER BOXES SHALL BE INSTALLED DIRECTLY BEHIND CURB.
5. SPLICES WILL NOT BE PERMITTED BETWEEN CORPORATION STOP AND ANGLE METER STOP EXCEPT WHEN SERVICE LINE EXCEEDS 60 FEET. SILVER SOLDER COPPER COUPLINGS SHALL BE USED FOR NECESSARY SPLICES FOR SERVICE LINES OVER 60 FEET.
6. METER BOXES SHALL NOT BE INSTALLED WHERE SUBJECT TO VEHICULAR LOADING.
7. WATER SERVICE ASSEMBLY SHALL BE INSTALLED WITHIN THE CITY'S RIGHT OF WAY, NO METER BOX SHALL BE INSTALLED ON PRIVATE PROPERTY.

**CONSTRUCTION ITEMS/MATERIALS LIST**

ITEM NO.	SIZE AND DESCRIPTION	MANUFACTURER	MFR. CAT. NO. OR SPEC.
①	AWWA APPROVED DOUBLE BANDED BRASS TAPPING SADDLE	JAMES JONES/MUELLER/FORD	_____
②	BRONZE CORPORATION STOP WITH IP THREAD X FLARE	JAMES JONES/MUELLER/FORD	_____
③	BRONZE ANGLE METER STOP WITH LOCKWING FLARE	JAMES JONES/MUELLER/FORD	_____
④	1" COPPER TUBING WITH 4" SAND BEDDING ALL AROUND	_____	TYPE "K" SOFT
⑤	CUSTOMER SERVICE VALVE REQUIRED ON CUSTOMER SIDE OF METER. METER AND CUSTOMER SERVICE VALVE TO BE PURCHASED FROM THE CITY.	JAMES JONES/MUELLER/FORD	_____
⑥	METER BOX	J&R PRODUCTS	W5-POLYMER
⑦	METER BOX LID	J&R PRODUCTS	W5-POLYMER (TWO PIECE)

APPROVED BY:

*W.E. Cameron*  
**W.E. CAMERON, CITY ENGINEER**

23784 62800  
**R.C.E. NO. DATE**



**City of San Clemente**  
 Public Works Department - Engineering Division

STD.NO.

**1-Inch Water Service Assembly**

**W-1**

MARK REVISIONS APPR. DATE

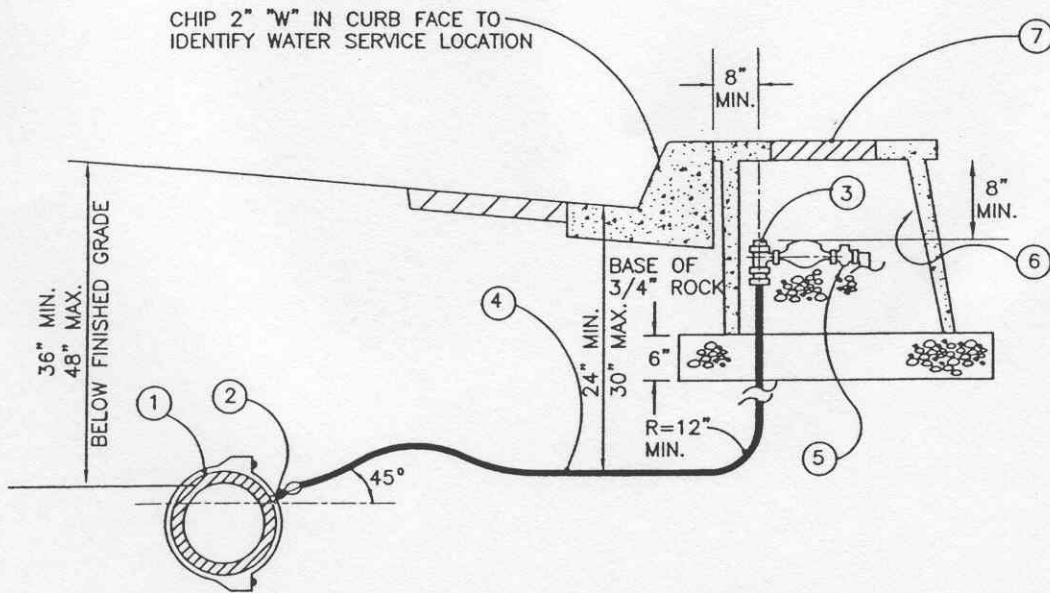

**NOTES:**

1. INSTALL CORPORATION STOP WITH KEY SIDEWAYS IN OPEN POSITION.
2. WATER SERVICE LINES SHALL BE INSTALLED PERPENDICULAR TO THE CENTERLINE OF THE STREET EXCEPT IN CUL-DE-SAC ENDS.
3. METER FITTINGS TO BE SAME SIZE AS SERVICE LINE.
4. METER BOXES SHALL BE INSTALLED DIRECTLY BEHIND CURB.
5. SPLICES WILL NOT BE PERMITTED BETWEEN CORPORATION STOP AND ANGLE METER STOP EXCEPT WHEN SERVICE LINE EXCEEDS 60 FEET. SILVER SOLDER COPPER COUPLINGS SHALL BE USED FOR NECESSARY SPLICES FOR SERVICE LINES OVER 60 FEET.
6. METER BOXES SHALL NOT BE INSTALLED WHERE SUBJECT TO VEHICULAR LOADING.
7. METER INSTALLATION LARGER THAN 2-INCH REQUIRES A VAULT AND APPROVAL OF DESIGN.
8. WATER SERVICE ASSEMBLY SHALL BE INSTALLED WITHIN THE CITY'S RIGHT OF WAY, NO METER BOX SHALL BE INSTALLED ON PRIVATE PROPERTY.

**CONSTRUCTION ITEMS/MATERIALS LIST**

ITEM NO.	SIZE AND DESCRIPTION	MANUFACTURER	MFR. CAT. NO. OR SPEC.
①	AWWA APPROVED DOUBLE BANDED BRASS TAPPING SADDLE	JAMES JONES/MUELLER/FORD	_____
②	BRONZE CORPORATION STOP WITH IP THREAD X FLARE	JAMES JONES/MUELLER/FORD	_____
③	BRONZE ANGLE METER STOP WITH LOCKWING FLARE	JAMES JONES/MUELLER/FORD	_____
④	2" COPPER TUBING WITH 6" SAND BEDDING ALL AROUND	_____	TYPE "K" SOFT
⑤	CUSTOMER SERVICE VALVE REQUIRED ON CUSTOMER SIDE OF METER. METER AND CUSTOMER SERVICE VALVE TO BE PURCHASED FROM THE CITY.	JAMES JONES/MUELLER/FORD	H-14244
⑥	METER BOX	J&R PRODUCTS	W5 <sub>2</sub> -POLYMER
⑦	METER BOX LID	J&R PRODUCTS	W5 <sub>2</sub> -POLYMER (TWO PIECE)

APPROVED BY:

*W. Cameron*  
W.E. CAMERON, CITY ENGINEER

23764 6-28-00  
R.C.E. NO. DATE



*City of San Clemente*  
Public Works Department - Engineering Division

STD.NO.

**2-Inch Water Service Assembly**

**W-2**

MARK	REVISIONS	APPR.	DATE

D:\standards\dwg\W-2.dwg 04/24/00 02:39:27 PM PDT

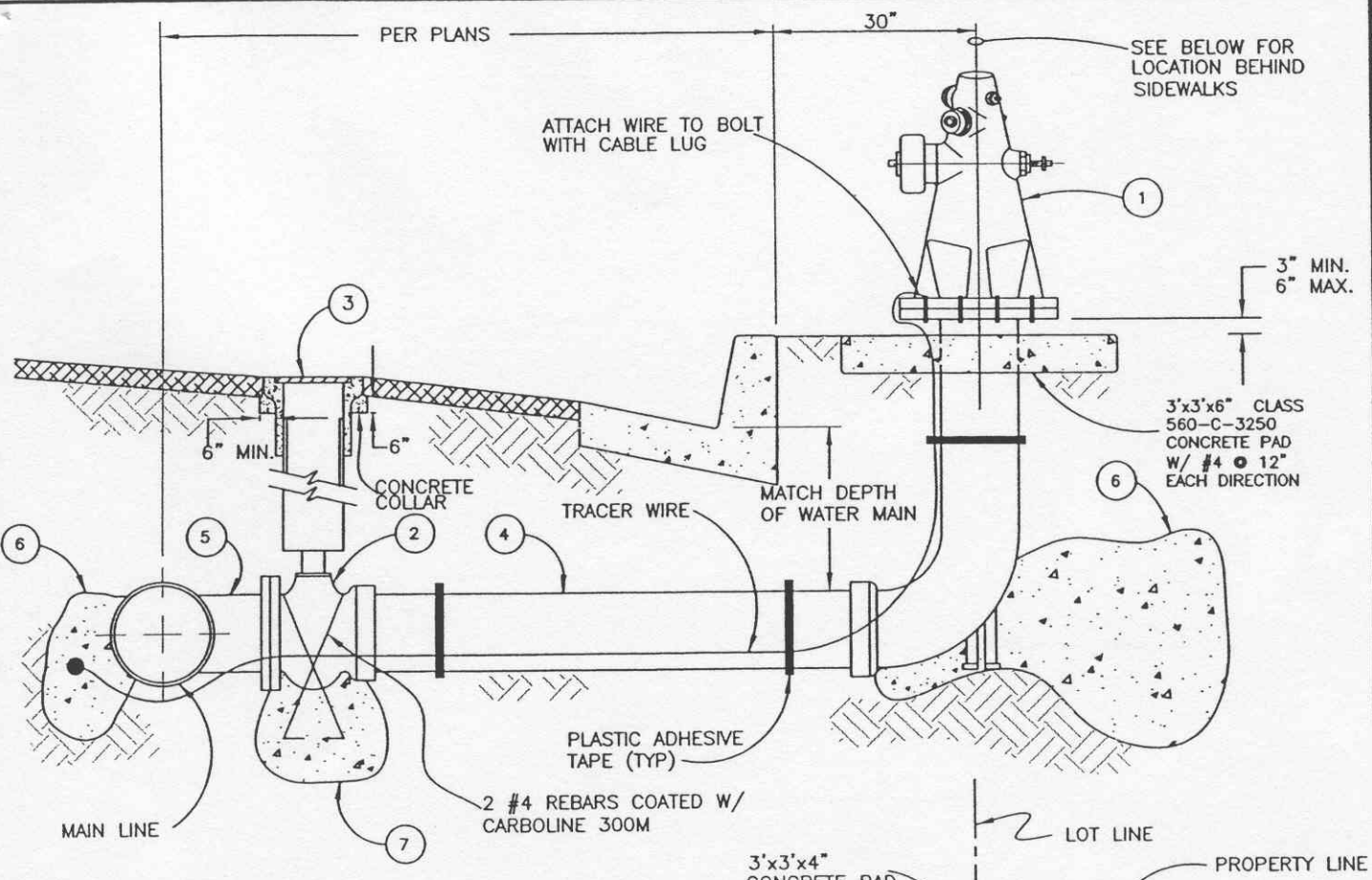

**NOTES:**

1. FIRE HYDRANT SHALL BE INSTALLED WITH 4" OUTLET PERPENDICULAR TO THE CURB FACE.
2. ALL NUTS, BOLTS, AND WASHERS SHALL BE 316 STAINLESS STEEL.
3. IN AREAS WHERE NO CURB OR BERM EXISTS, OR THERE IS ONLY ROLLED CURB AND GUTTER, INSTALL TWO 3" GALVANIZED STEEL POSTS, ONE AT EACH CORNER OF CONCRETE PAD ON TRAFFIC SIDE. IMBED POSTS IN 24" OF CONCRETE 2 FEET BELOW GRADE AND EXTEND 3 FEET ABOVE GRADE.
4. FIRE HYDRANTS AND POSTS TO BE PAINTED WITH TWO COATS OF PERVO 2420 SAFETY YELLOW OR HB FULLER HYBRID YELLOW, IF-6720.

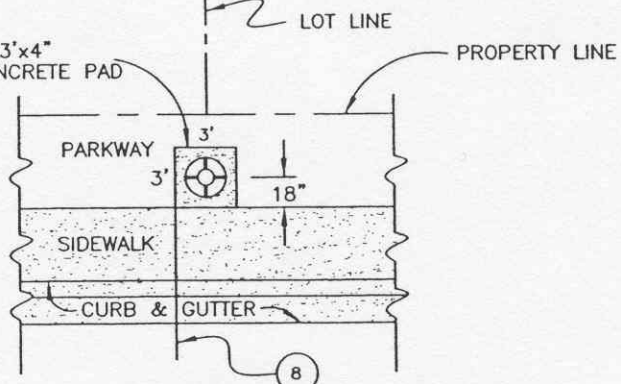

LOCATION OF HYDRANT  
(SIDEWALK ADJACENT TO CURB)

**CONSTRUCTION ITEMS/MATERIALS LIST**

ITEM No.	SIZE AND DESCRIPTION	MANUFACTURER	MFR. CAT. No. OR SPEC.
①	WET BARREL FIRE HYDRANT, W/ TWO(2) 2 1/2", AND 4" OUTLETS W/ CAST BRONZE CAPS, 1 1/2" PENTAGONAL OPERATING NUTS AND 6 MOUNTING BOLTS, "BREAKAWAY" TYPE.	CLOW JONES A.V.K.	MODEL 860 MODEL J4060D MODEL 24-150-50
②	6" RESILIENT WEDGE GATE VALVE, FLANGE, AND PUSH ON	---	PER STD DRAWING W-4&W-5
③	VALVE BOX ASSEMBLY	TYLER	6855 SERIES
④	CLASS 350 PSI DIP	---	---
⑤	DUCTILE IRON "TEE" AS REQUIRED W/ 6" FLANGE FOR HYDRANT VALVE	---	---
⑥	THRUST BLOCK	---	PER STD DRAWING W-6
⑦	ANCHOR BLOCK	---	PER STD DRAWING W-4
⑧	KEEP HYDRANT OUT OF CURB RADIUS AT INTERSECTIONS	---	---

APPROVED BY:  
  
 W.E. CAMERON, CITY ENGINEER      23784      6/28/00  
 R.C.E. NO.      DATE



**City of San Clemente**  
 Public Works Department - Engineering Division

MARK	REVISIONS	APPR.	DATE

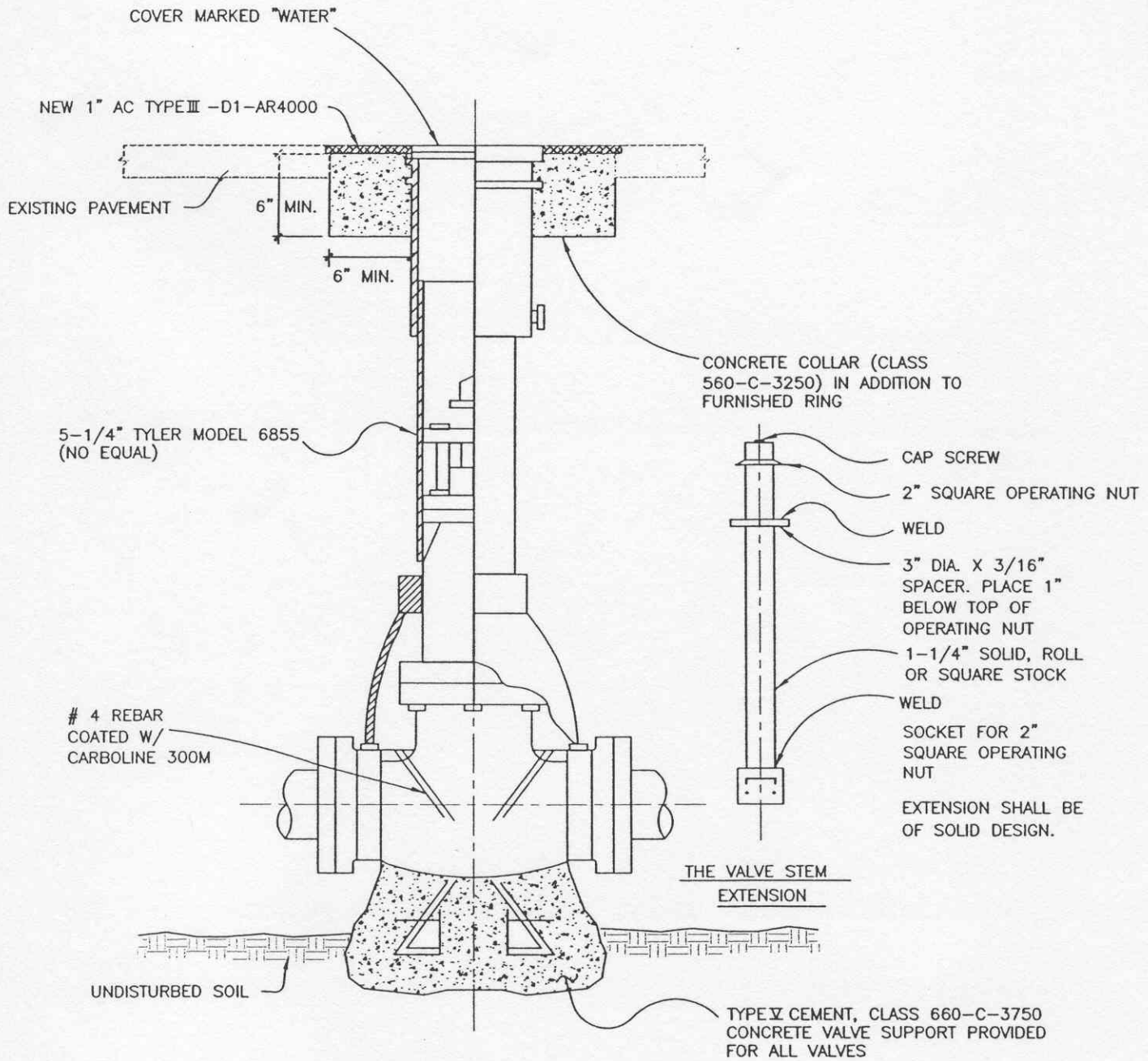

STD. NO.  
**Fire Hydrant Assembly**      W-3

D:\s\standards\dwg\W-3.dwg 06/01/00 01:44:20 PM PDT

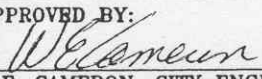

**NOTE:**

THREE FLANGE BY PUSH ON RESILIENT WEDGE GATE VALVES SHALL BE INSTALLED AT ALL TEE & FITTINGS.  
 FOUR FLANGE BY PUSH ON RESILIENT WEDGE GATE VALVES SHALL BE INSTALLED AT ALL CROSS FITTINGS.

APPROVED BY:  W.E. CAMERON, CITY ENGINEER				23764 R.C.E. NO.		6-28-00 DATE		 <b>City of San Clemente</b> Public Works Department - Engineering Division	
				STD.NO.					
				W-4					
				<b>Valve &amp; Valve Box          Assembly</b>					
MARK	REVISIONS	APPR.	DATE						



SEE VALVE AND VALVE BOX  
ASSEMBLY STD. DWG. W-4

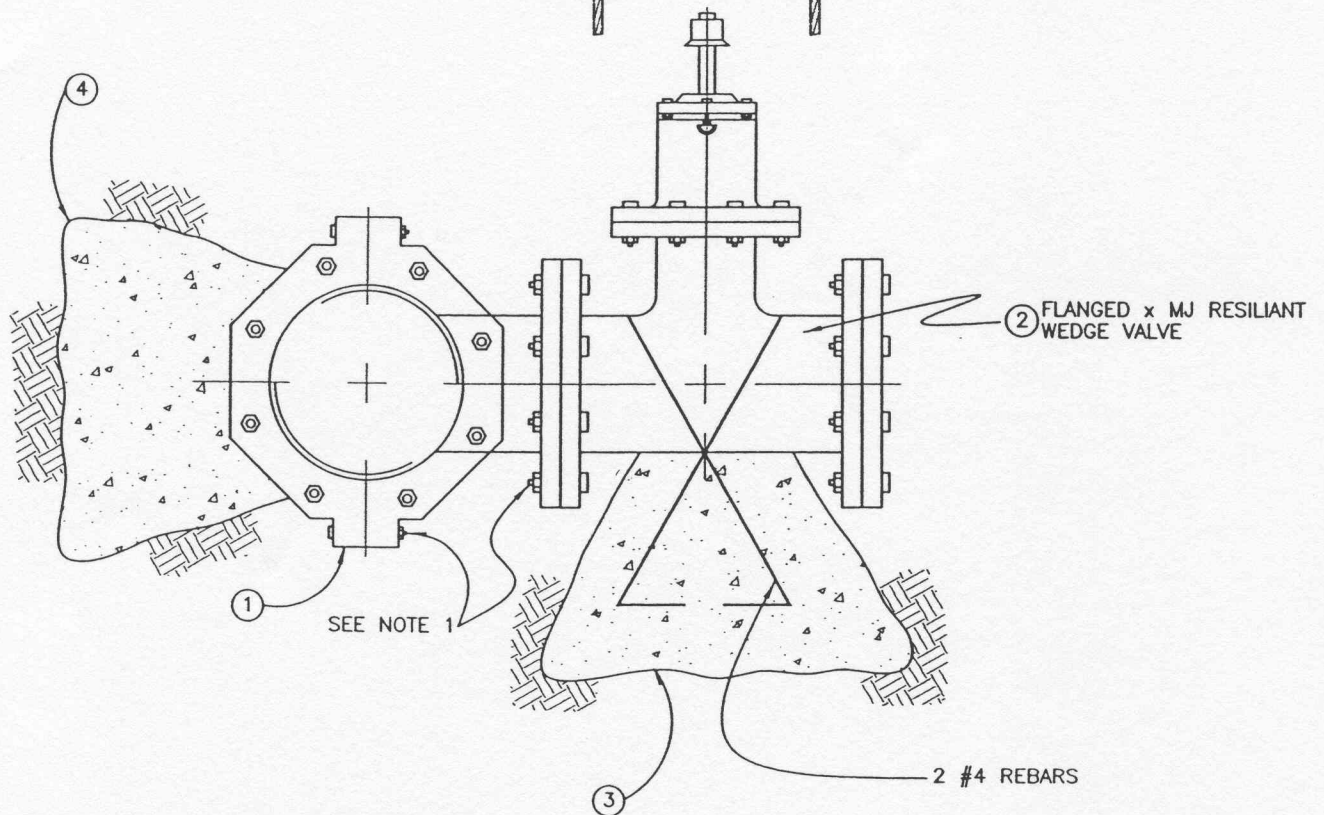

**NOTES:**

1. ALL NUTS, BOLTS AND WASHERS SHALL BE 316 STAINLESS STEEL.
2. ALL BURIED REBAR SHALL BE COATED WITH TWO COATS OF CARBOLINE 300M.
3. PROVIDE VALVE STEM EXTENSION IF DEPTH EXCEED 4 FEET. CONSTRUCTION OF VALVES REQUIRING VALVE STEM EXTENSION MUST BE APPROVED BY THE CITY ENGINEER.
4. TAP ON EXISTING MAIN SHALL BE MIN. ONE SIZE SMALLER THAN MAIN.
5. TAP ON EXISTING MAIN SHALL BE MIN. 2 FEET FROM A COUPLING OR SERVICE.

**CONSTRUCTION ITEMS/MATERIALS LIST**

ITEM No.	SIZE AND DESCRIPTION	MANUFACTURER	MFR. CAT. No. OR SPEC.
①	AWWA APPROVED 316 STAINLESS STEEL TAPPING SLEEVE	MUELLER CLOW/SMITH BLAIR	_____
②	RESILIENT WEDGE GATE VALVE	M & H MUELLER AMERICAN FLOW CONTROL	4067 2360 SERIES 2500
③	ANCHOR BLOCK	_____	PER STD. DRAWING W-4
④	THRUST BLOCK	_____	PER STD. DRAWING W-6

APPROVED BY:

*W.E. Cameron*  
W.E. CAMERON, CITY ENGINEER

23764 6-28-00  
R.C.E. NO. DATE



*City of San Clemente*  
Public Works Department - Engineering Division

MARK	REVISIONS	APPR.	DATE

Tapping Sleeve and  
Valve Assembly

STD.NO.  
W-5

D:\standards\dwg\W-5.dwg 03/07/00 03:14:39 PM PST

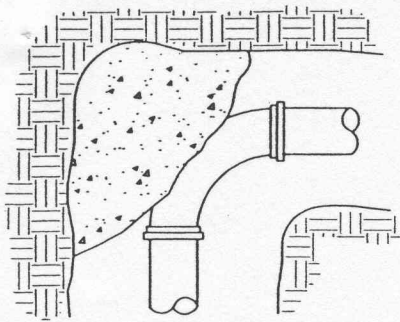

90° BEND

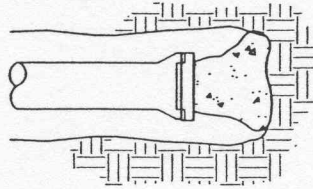

END CAP

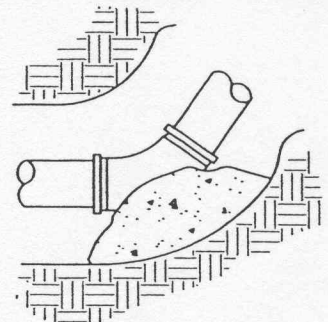

45° BEND

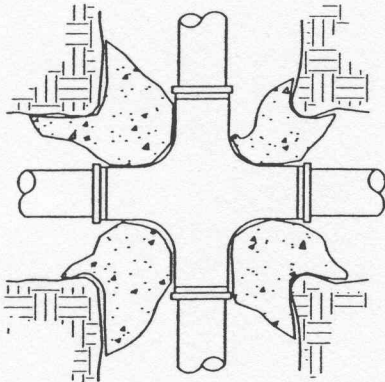

CROSS

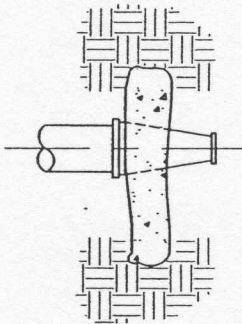

REDUCER

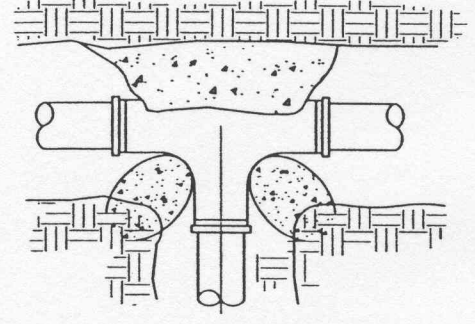

TEE

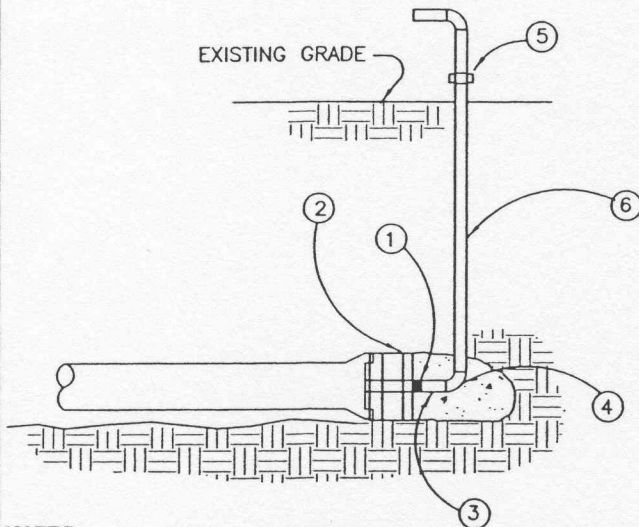

**CONSTRUCTION TEMPORARY BLOW OFF & CHLORINATION ASSEMBLY  
LEGEND OF MATERIALS**

- ① RIGID BRASS REDUCING, BUSHING (2-1/2" X 2")
- ② C.I. PLUG - TAPPED 2-1/2"
- ③ 2" BRASS NIP
- ④ 2" BRASS 90 DEGREE ELL
- ⑤ 2" BRASS BALL VALVE
- ⑥ 2" COPPER RISER MATERIAL

**NOTES:**

- 1. TEMPORARY BLOW-OFF ASSEMBLY REQUIRED AT ALL DEAD END LINES WITH HYDRANTS.
- 2. REMOVE RISER MATERIAL AFTER FLUSHING AND INSTALL 2" BRASS PLUG IN VALVE. LEAVE VALVE CLOSED.

**NOTES:**

- 1. BASED ON SOIL BEARING VALUE OF 1,500 PSF AND 225 PSI PRESSURE AND MINIMUM 3' OF COVER:  
FOR BRG.=1,000 PSF; 1.5 TIMES AREA SHOWN.  
FOR BRG.=500 PSF; 3.0 TIMES AREA SHOWN.
- 2. ALL ANCHORS AND THRUST BLOCKS SHALL BE PLACED AGAINST UNDISTURBED SOIL. ENGINEER WILL DETERMINE SIZES NOT SHOWN.
- 3. THRUST BLOCKS ON CROSSES SHALL BE USED WHEREVER PIPE SIZES DIFFER OR WHEN ONE OR MORE OPENINGS ARE PLUGGED.
- 4. ALL THRUST BLOCKS SHALL BE OF TYPE ∇ CEMENT, CLASS 660-C-3750 CONCRETE.

**MINIMUM BEARING AREA IN SQUARE FEET**

MAIN SIZE	TEE D.E.	90° BEND	45° BEND	22-1/2" BEND	END CAP	CROSS EACH WAY	VERT. BEND
4"	4	5	3	1.5	3	1	4
6"	8	10	5	2.5	6	2	8
8"	12	16	9	4.5	10	3	12
10"	17	24	13	6.5	16	5	17
12"	24	33	19	9.5	23	7	24

D:\standards\dwg\W-6.dwg 03/07/00 03:40:57 PM PST

APPROVED BY:

*W.E. Cameron*  
W.E. CAMERON, CITY ENGINEER

23764 6-28-00  
R.C.E. NO. DATE



**City of San Clemente**  
Public Works Department - Engineering Division

MARK	REVISIONS	APPR.	DATE

**Thrust Blocks and Temporary  
Blow off/chlorination Assembly**

STD.NO.

**W-6**



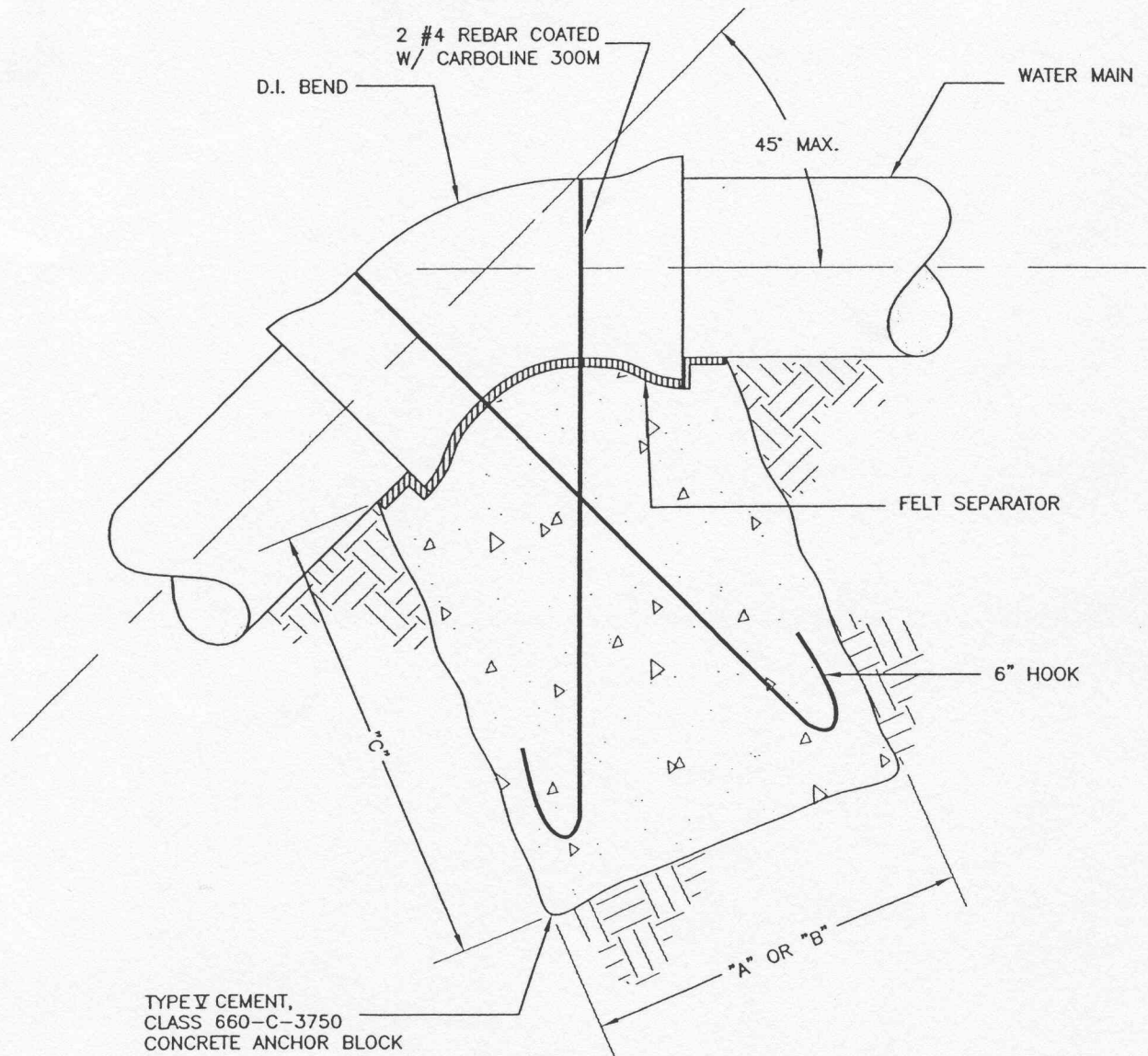

D.I. BEND	CONCRETE ANCHOR BLOCK			TIE BAR LENGTH
	"A" LENGTH	"B" WIDTH	"C" DEPTH	
6"	2.0'	2.0'	2.5'	8.5'
8"	2.5'	2.5'	2.5'	9.0'
10"	3.0'	3.0'	3.5'	11.5'
12"	4.0'	4.0'	4.0'	12.0'

**NOTE:**

TIE BARS NOT EMBEDDED IN CONCRETE SHALL BE CLEANED AND COATED WITH CARBOLINE 300.

D:\standards\dwg\W-7.dwg 03/07/00 03:20:04 PM PST

APPROVED BY:

*W. E. Cameron*  
W.E. CAMERON, CITY ENGINEER

23764 6/29/00  
R.C.E. NO. DATE



*City of San Clemente*  
Public Works Department - Engineering Division

MARK	REVISIONS	APPR.	DATE

Thrust Block Details  
(vertical)

STD.NO.

W-7

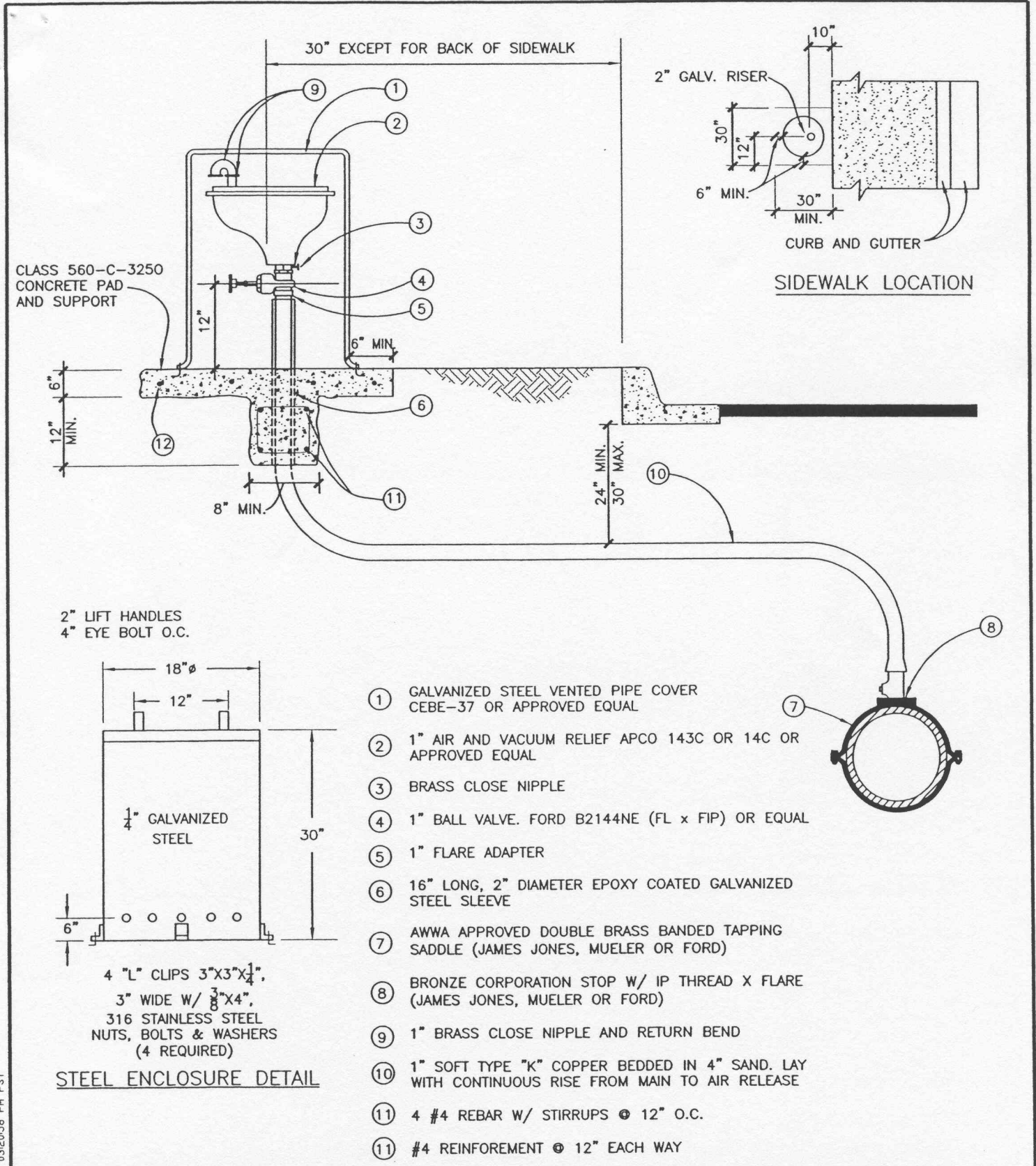

2" LIFT HANDLES  
4" EYE BOLT O.C.

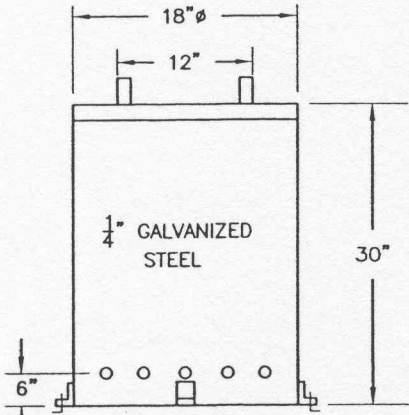

4 "L" CLIPS 3"x3"x $\frac{1}{4}$ ",  
3" WIDE W/ $\frac{3}{8}$ "x4",  
316 STAINLESS STEEL  
NUTS, BOLTS & WASHERS  
(4 REQUIRED)  
**STEEL ENCLOSURE DETAIL**

- ① GALVANIZED STEEL VENTED PIPE COVER CEBE-37 OR APPROVED EQUAL
- ② 1" AIR AND VACUUM RELIEF APCO 143C OR 14C OR APPROVED EQUAL
- ③ BRASS CLOSE NIPPLE
- ④ 1" BALL VALVE. FORD B2144NE (FL x FIP) OR EQUAL
- ⑤ 1" FLARE ADAPTER
- ⑥ 16" LONG, 2" DIAMETER EPOXY COATED GALVANIZED STEEL SLEEVE
- ⑦ AWWA APPROVED DOUBLE BRASS BANDED TAPPING SADDLE (JAMES JONES, MUELER OR FORD)
- ⑧ BRONZE CORPORATION STOP W/ IP THREAD X FLARE (JAMES JONES, MUELER OR FORD)
- ⑨ 1" BRASS CLOSE NIPPLE AND RETURN BEND
- ⑩ 1" SOFT TYPE "K" COPPER BEDDED IN 4" SAND. LAY WITH CONTINUOUS RISE FROM MAIN TO AIR RELEASE
- ⑪ 4 #4 REBAR W/ STIRRUPS @ 12" O.C.
- ⑪ #4 REINFORCEMENT @ 12" EACH WAY

D:\standards\dwg\W-8.dwg 03/07/00 09:20:58 PM PST

APPROVED BY: *W.E. Cameron*  
W.E. CAMERON, CITY ENGINEER  
23784 R.C.E. NO. 6/28/00 DATE



**City of San Clemente**  
Public Works Department - Engineering Division

MARK	REVISIONS	APPR.	DATE

**Air and Vacuum Relief Valve Assembly**

STD.NO.  
**W-8**



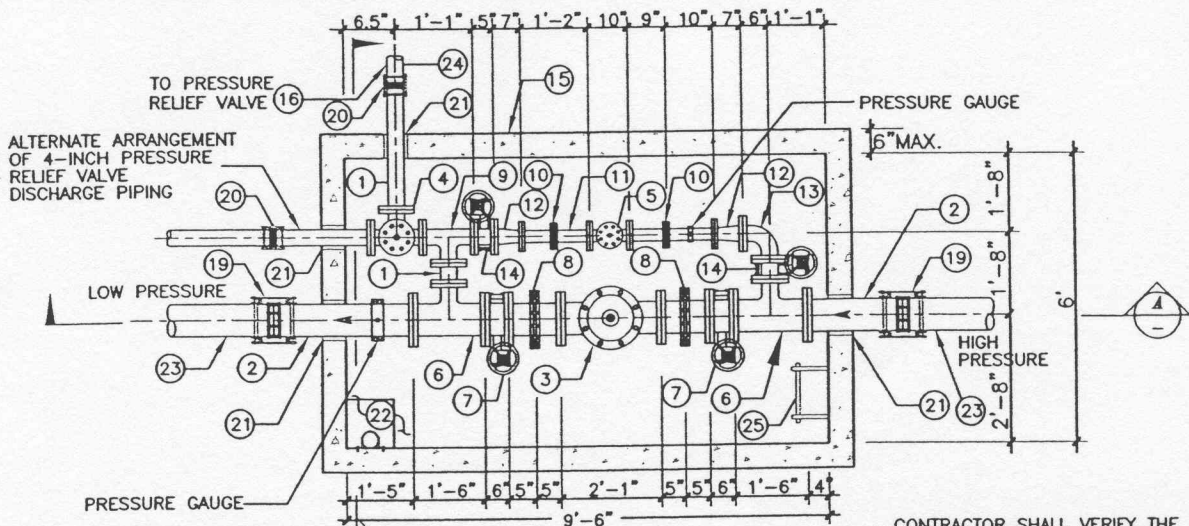

MECHANICAL PLAN

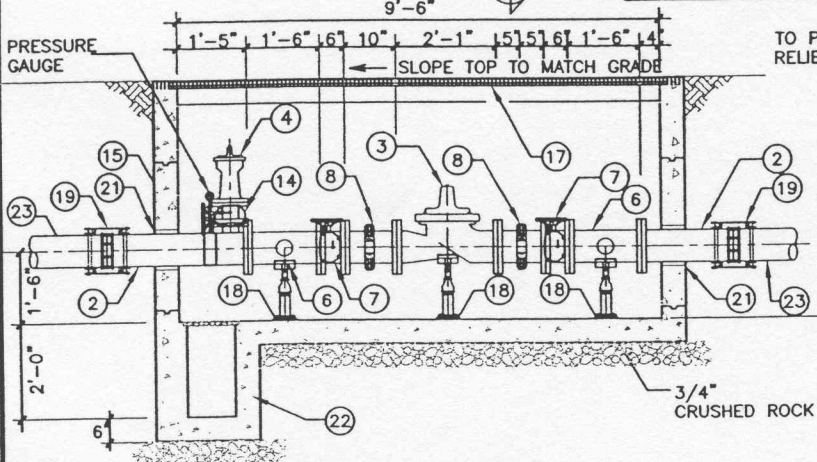

MECHANICAL SECTION A

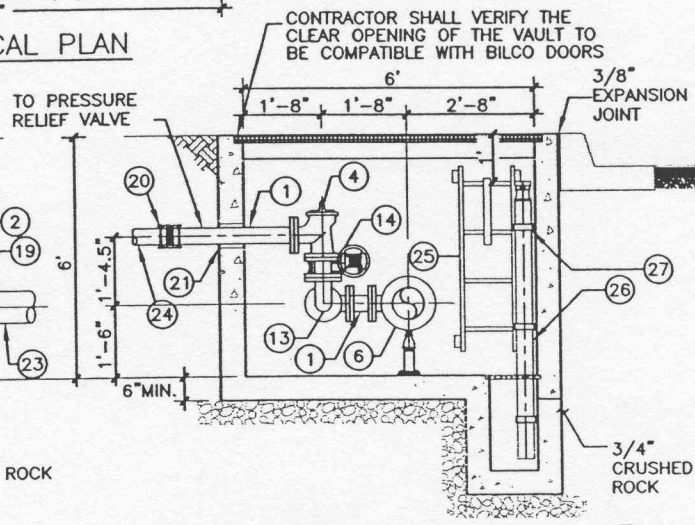

MECHANICAL SECTION B

NOTES:

- ① 4-INCH CLASS 53 FUSION BONDED EPOXY LINED AND COATED PIPE
- ② 8-INCH CLASS 53 FUSION BONDED EPOXY LINED AND COATED PIPE
- ③ 8-INCH FLANGED PRESSURE REDUCING/PRESSURE SUSTAINING VALVE
- ④ 4-INCH FLANGED ANGLE STYLE PRESSURE RELIEF VALVE
- ⑤ 3-INCH FLANGED PRESSURE REDUCING/PRESSURE SUSTAINING VALVE
- ⑥ 8" x 4" FLANGED, EPOXY LINED AND COATED DUCTILE IRON TEE
- ⑦ 8-INCH CLASS 150 FLANGED BUTTERFLY VALVE WITH HAND WHEEL OPERATOR M&H OR APPROVED EQUAL
- ⑧ 8-INCH STYLE HP-70 VICTAULIC COUPLING
- ⑨ 4" x 4" FLANGED, EPOXY LINED AND COATED DUCTILE IRON TEE
- ⑩ 3-INCH STYLE HP-70 VICTAULIC COUPLING
- ⑪ 3-INCH CLASS 53 EPOXY LINED AND COATED DUCTILE IRON SPOOL
- ⑫ 4" x 3" FLANGED, EPOXY LINED AND COATED DUCTILE IRON CONCENTRIC REDUCER
- ⑬ 4-INCH FLANGED, EPOXY LINED AND COATED DUCTILE IRON 90° BEND
- ⑭ 4-INCH CLASS 150 FLANGED BUTTERFLY VALVE WITH HAND WHEEL OPERATOR MH OR APPROVED EQUAL
- ⑮ PRECAST CONCRETE VAULT
- ⑯ STEEL ENCLOSURE FOR AIR & VACUUM RELIEF VALVE
- ⑰ ACCESS HATCH: 6'-0" x 9'-6" DOUBLE LEAF, ALUMINUM HATCH, TRAFFIC RATED FOR CONTINUOUS H2O LOADING, BILCO MODEL JDAL H2O (DEPTH 8 1/2" MIN.). PARKWAY TYPE BILCO MODEL JDAL (DEPTH 3 1/2" MIN.) DOUBLE LEAF, ALUMINUM HATCH
- ⑱ ADJUSTABLE PIPE SUPPORT
- ⑲ 8-INCH FLEXIBLE COUPLING WITH STAINLESS STEEL TIE ROD & ANCHOR JOINT RESTRAINT
- ⑳ 4-INCH FLEXIBLE COUPLING WITH STAINLESS STEEL TIE ROD & ANCHOR JOINT RESTRAINT
- ㉑ VAULT WALL PENETRATION
- ㉒ 12"x12" VAULT SUMP WITH CAST IRON FRAME AND GRATE ALHAMBRA FOUNDRY A-2010 OR EQUAL. THE GRATE SHALL INCLUDE A CUT OUT FOR 4-INCH SUMP SUCTION PIPING
- ㉓ 8-INCH CLASS 350 CEMENT MORTAR LINED DUCTILE IRON PIPE
- ㉔ 4-INCH CLASS 53 CEMENT MORTAR LINED DUCTILE IRON PIPE
- ㉕ GALVANIZED STEEL LADDER WITH BILCO LADDER UP SAFETY POST TO BE INSTALLED A MIN. OF 1'-0" SURFACE
- ㉖ 3-INCH STAINLESS STEEL PIPE AND 3-INCH CAMLOCK QUICK COUPLING (FEMALE)
- ㉗ 316 STAINLESS STEEL PIPE CLAMP ATTACHED TO 1" UNISTRUT CHANNEL CLAMP. UNISTRUT P1120 OR EQUAL

NOTE: PLANS FOR PRESSURE REDUCING STATION MUST BE SUBMITTED FOR THE CITY ENGINEER'S APPROVAL.

APPROVED BY:

*W.E. Cameron*  
W.E. CAMERON, CITY ENGINEER

23764 6-28-00  
R.C.E. NO. DATE



City of San Clemente  
Public Works Department - Engineering Division

STD.NO.

Pressure Reducing Station

W-9

MARK	REVISIONS	APPR.	DATE

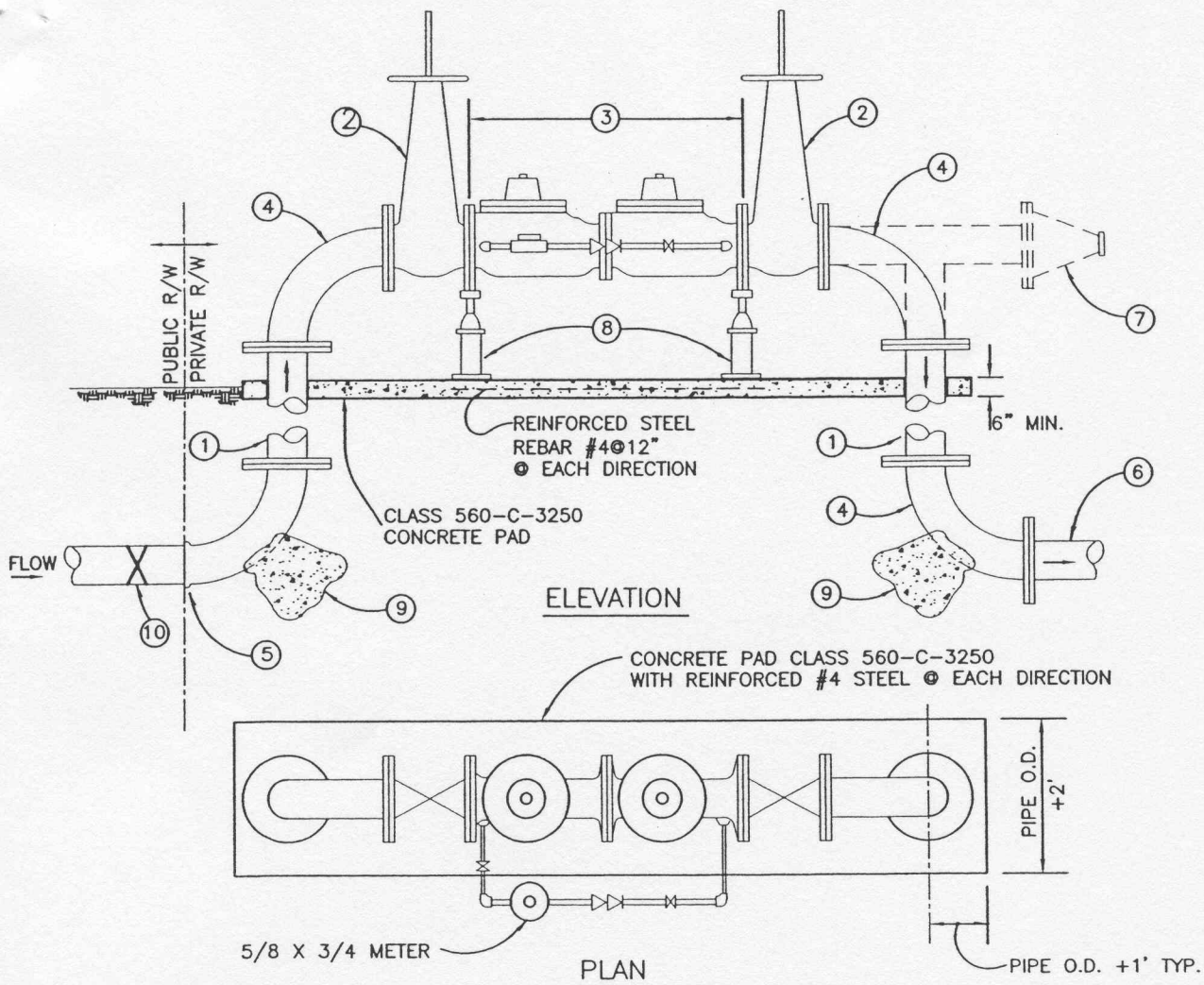

**NOTES:**

- |  |   |
|--|---|
| <p>1. ASSEMBLIES SHALL BE ON THE LATEST APPROVED LIST OF BACKFLOW PREVENTION DEVICES FROM CALIFORNIA DEPARTMENT OF HEALTH SERVICES.</p> <p>2. INSTALLATION SHALL COMPLY WITH THE LATEST PLUMBING CODES AND APPLICABLE CITY STANDARDS REQUIREMENTS.</p> <p>3. UPON COMPLETION OF THE INSTALLATION OF THE ASSEMBLY, TEST SHALL BE PERFORMED AND A CERTIFICATE OF ADEQUACY AND OPERATIONAL COMPLIANCE SHALL BE FURNISHED.</p> <p>4. ALL ABOVE GROUND PIPING SHALL BE PRIMED AND PAINTED WITH TWO COATS OF OSHA RED.</p> <p>5. SUBMIT PLANS OF ENTIRE ASSEMBLY PRIOR TO INSTALLATION FOR CITY ENGINEER'S APPROVAL.</p> | <p>① DUCTILE IRON SPOOL CLASS 350</p> <p>② RESILIENT WEDGE GATE VALVE OS 8 Y</p> <p>③ CAL. DEPT. OF HEALTH SERVICES APPROVED DOUBLE CHECK DETECTOR ASSEMBLY WITH 3/4" BYPASS METER. AMES 3000SS OR FEBCO 805 YD OR WATTS 709 DCDA</p> <p>④ DUCTILE IRON FLANGE LONG RADIUS 90°</p> <p>⑤ DUCTILE IRON PUSH-ON X FLANGE LONG RADIUS 90°</p> <p>⑥ TO FIRE SYSTEM</p> <p>⑦ 2 1/2-INCH SIAMESE FIRE DEPT. CONNECTION (CITY ENGINEER'S OPTION)</p> <p>⑧ ADJUSTABLE PIPE SUPPORT. GRINNELL # 264 OR APPROVED EQUAL</p> <p>⑨ THRUST BLOCK PER CITY STANDARD DRAWING W-6</p> <p>⑩ RESILIENT WEDGE GATE VALVE PER CITY STANDARD DRAWING W-4</p> |
|--|---|

APPROVED BY:

*W.E. Cameron*  
**W.E. CAMERON, CITY ENGINEER**

23764 6-28-00  
**R.C.E. NO. DATE**

*City of San Clemente*

Public Works Department - Engineering Division

MARK	REVISIONS	APPR.	DATE

**Backflow Preventer Assembly  
(Dual check valve w/detector)**

STD.NO.  
**W-10**



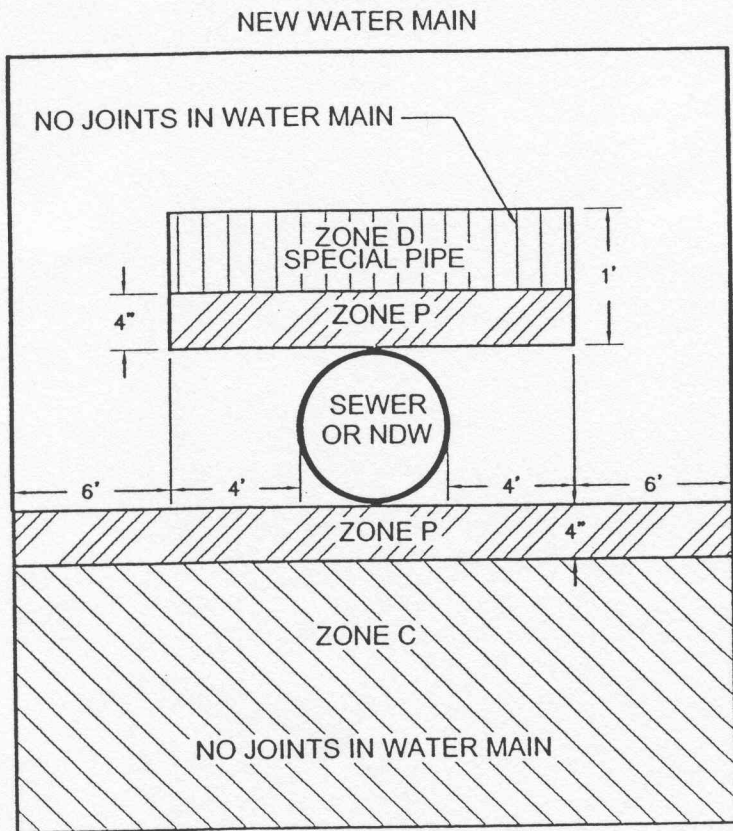

CROSSINGS OF SEWER OR NDW

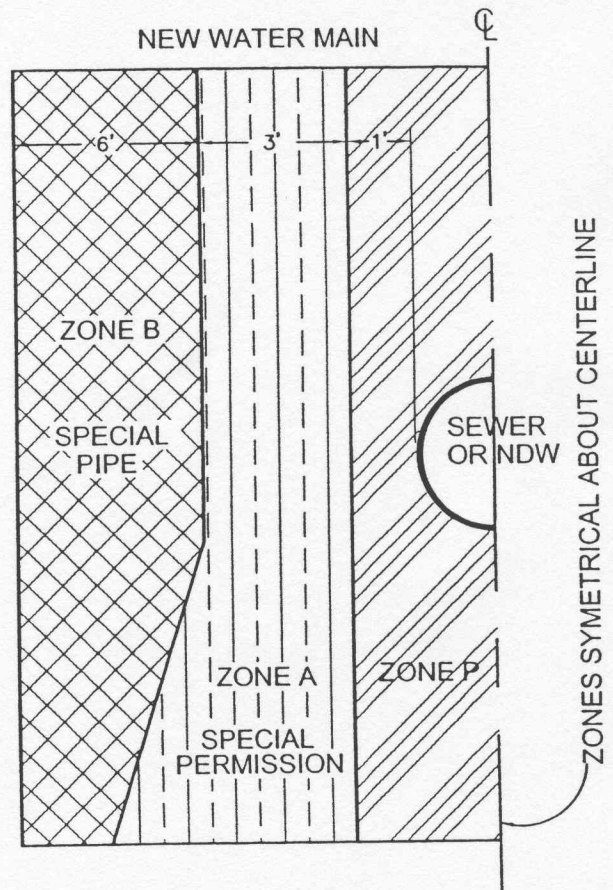

PARALLEL TO SEWER OR NDW

**ZONE COSNTRUCTION REQUIREMENTS FOR DOMESTIC WATER MAINS**

A	SPECIAL PERMISSION REQUIRED. DO NOT LOCATE ANY PARALLEL WATER MAIN IN THIS AREA WITHOUT CITY ENGINEER AND STATE HEALTH DEPARTMENT APPROVAL.
B	THE WATER MAIN SHALL BE DIP OR C900 PVC PIPE CLASS 200 WITH PUSH-ON TYPE RUBBER RING JOINTS.
C	THE WATER MAIN SHALL BE CONSTRUCTED AS DESCRIBED FOR ZONE B ABOVE, WITH THE EXCEPTION THAT THE WATER MAIN SHALL CONTAIN NO JOINTS IN ZONE C.
D	THE WATER MAIN SHALL BE CONSTRUCTED AS DESCRIBED FOR ZONE B ABOVE, WITH THE EXCEPTION THAT THE WATER MAIN SHALL CONTAIN NO JOINTS IN ZONE D.
P	PROHIBITED ZONE; NO DOMESTIC WATER MAINS SECTION 64630 (e) (2) CALIFORNIA ADMINISTRATIVE CODE, TITLE 22.

APPROVED BY:

*W.E. Cameron*  
W.E. CAMERON, CITY ENGINEER

23784 R.C.E. NO. 6-28-05 DATE



*City of San Clemente*  
Public Works Department - Engineering Division

STD.NO.

Pipe Separation:  
New Water Mains from  
Sewer or Non Domestic  
Water Mains

W-11

MARK	REVISIONS	APPR.	DATE

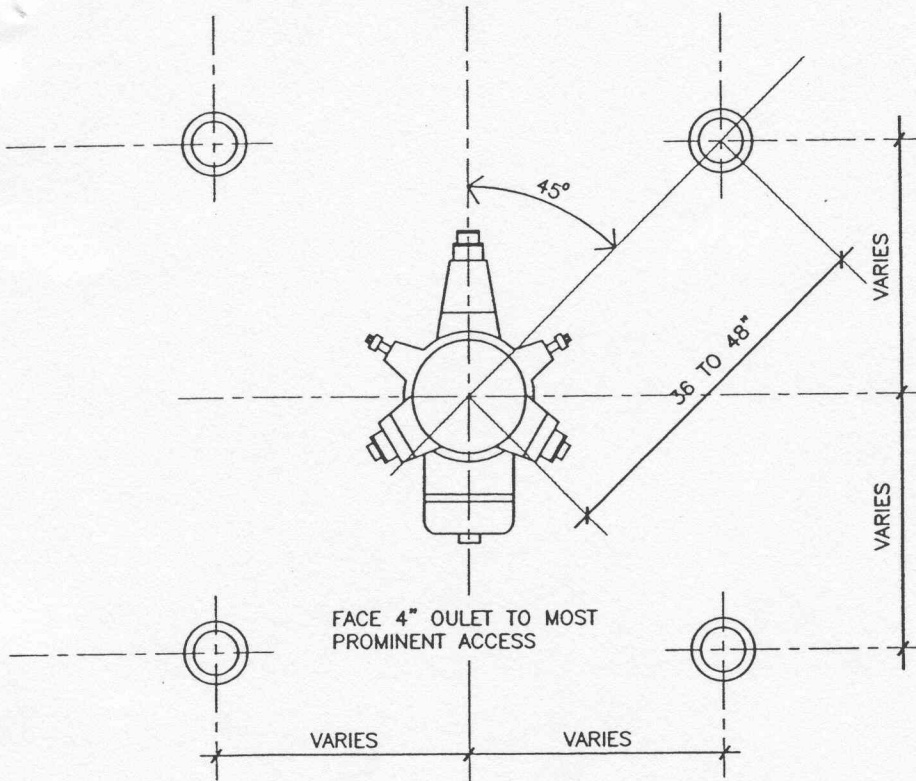

**NOTE:**

GUARD POST AROUND FIRE HYDRANTS SHALL BE PAINTED WITH 2 COATS OF PERVO 2420 SAFETY YELLOW OR HB FULLER HYBRIO YELLOW IF-6720.

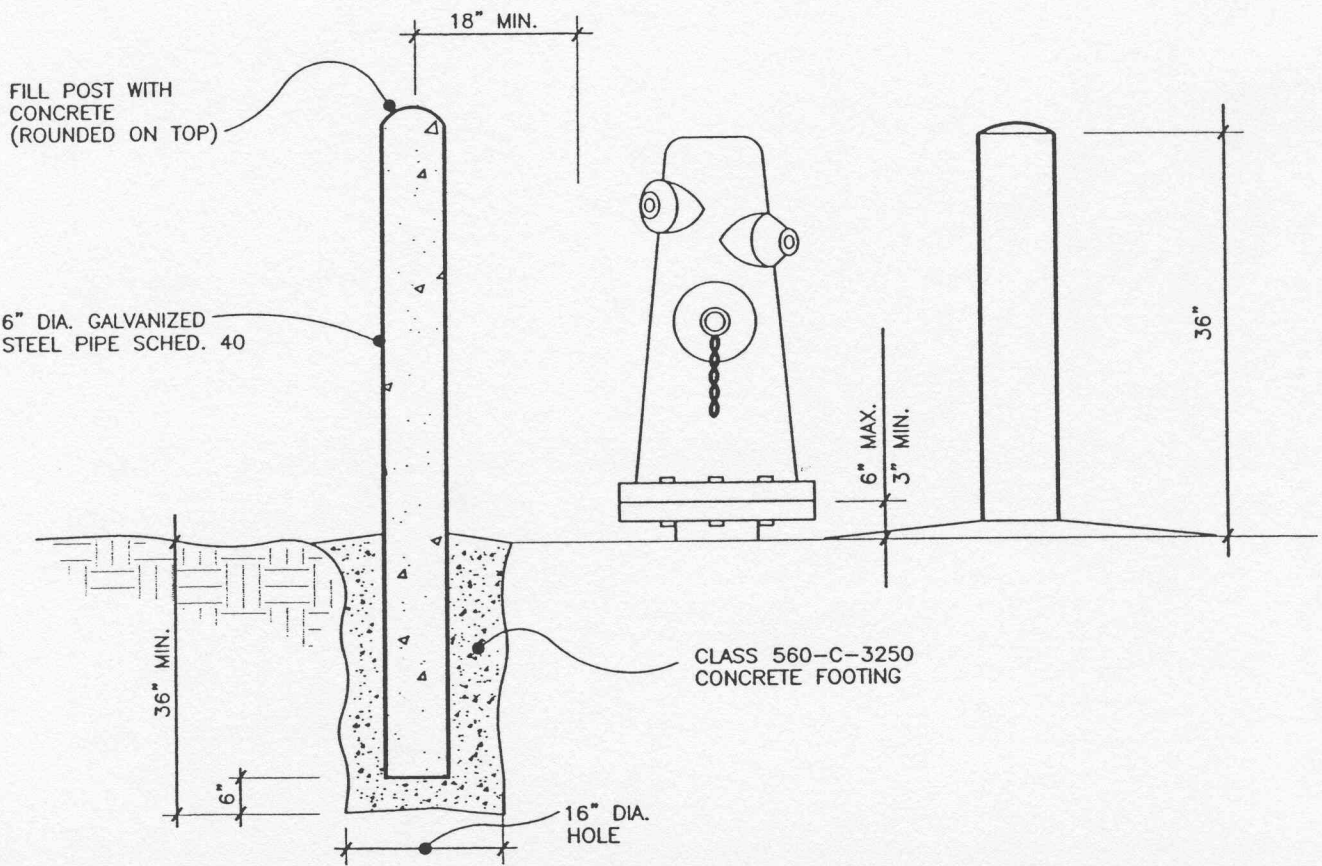

D:\standards\dwg\W-12.dwg 02/28/00 09:33:29 AM PST

APPROVED BY:

*W.E. Cameron*  
W.E. CAMERON, CITY ENGINEER

23764 6-28-00  
R.C.E. NO. DATE



*City of San Clemente*  
Public Works Department - Engineering Division

MARK	REVISIONS	APPR.	DATE

Fire Hydrant Barricades

STD.NO.  
W-12



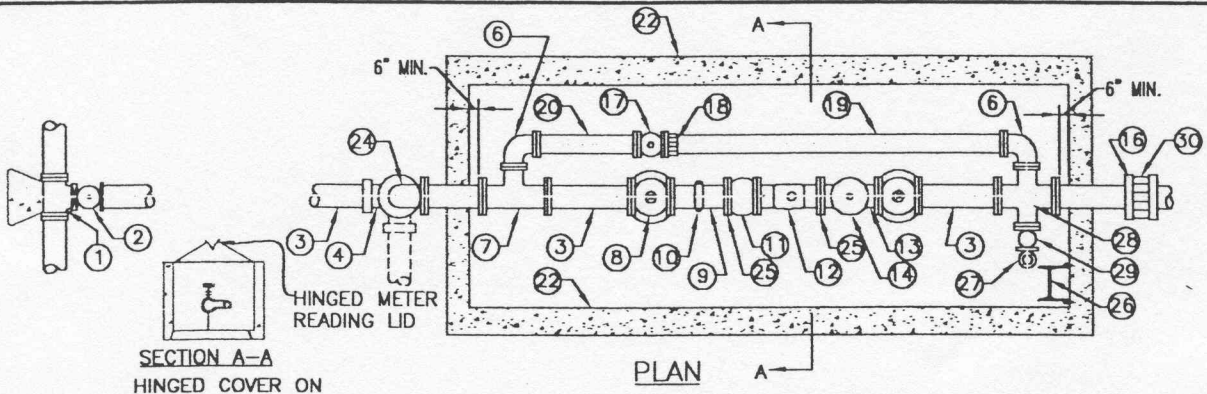

SECTION A-A  
HINGED COVER ON  
LONG SIDE

PLAN

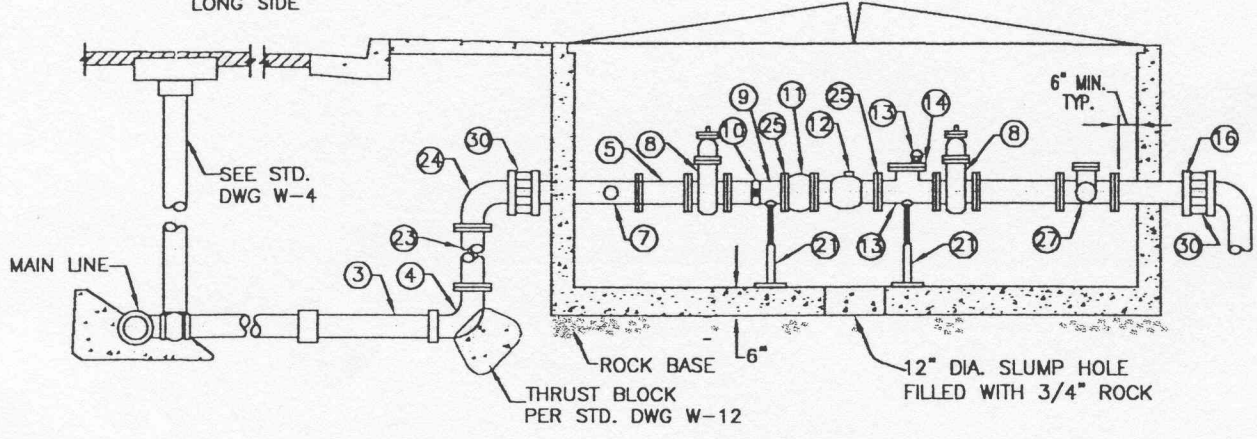

ELEVATION

**NOTES:**

- ① 1EA. SIZE X SIZE TAPPING SLEEVE (USE R-T X FLG. TEE IF HOT TAP IS NOT REQUIRED)
- ② 1EA. R-T X FLG. TAPPING VALVE (USE RESILIENT WEDGE GATE VALVE)
- ③ 1EA. CLASS 350 PSI DUCTILE IRON PIPE
- ④ 1EA. DUCTILE IRON 90° ELL FLG. X R-T
- ⑤ 2EA. FLG. X FLG. DUCTILE IRON SPOOL - METER SIZE X 1'-6"
- ⑥ 2EA. 4" DUCTILE IRON 90° BEND FLG. X FLG.
- ⑦ 2EA. METER SIZE X 4" FLANGED CAST IRON TEE
- ⑧ 2EA. RESILIENT WEDGE GATE VALVE FLG. X FLG.
- ⑨ 2EA. FLG. X GROOVED END DUCTILE IRON SPOOL FOR 6" DIA. PIPE. USE 9" LENGTH, 8" DIA. - 6" LENGTH, 10" DIA. - 9" LENGTH
- ⑩ 1EA. VICTAULIC COUPLING STYLE 77
- ⑪ 1EA. STRAINER
- ⑫ 1EA. TURBINE METER
- ⑬ 1EA. METER SIZE X 6" CAST IRON TEE - FLANGED
- ⑭ 1EA. 6" DUCTILE IRON BLIND FLANGE TAPPED FOR 2" I.P.
- ⑮ 1EA. 2" CORPORATION STOP - MIP X MIP
- ⑯ 4EA. DUCTILE IRON BLIND FLANGE
- ⑰ 1EA. 4" RESILIENT WEDGE VALVE ONLY - FLANGED O.S. & Y.
- ⑱ 1EA. 4" FLANGED COUPLING ADAPTER
- ⑲ 1EA. 4" DUCTILE IRON SPOOL - FLG X P.E.
- ⑳ 1EA. 4" X 2'-0" DUCTILE IRON SPOOL - FLG. X FLG.
- ㉑ 2EA. ADJUSTABLE GALVANIZED PIPE SUPPORT
- ㉒ 1EA. PRE CAST CONCRETE VAULT - ACCESS DOORS SHALL BE TYPE JDAL SIZED TO VAULT
- ㉓ 1EA. AS MANUFACTURED BY BILCO, DOOR SHALL BE CORROSION RESISTANT AND WARRANTED 25 YEARS & 6" X 12" HINGED READING LID OVER METER REGISTER FLG. X FLG. DUCTILE IRON SPOOL (IF REQUIRED)
- ㉔ 1EA. FLG. X FLG. 90° C.I. ELL FLG. X FLG.
- ㉕ 2EA. BOLT AND FLANGE INSULATING KIT
- ㉖ 1EA. GALVANIZED STEEL LADDER WITH BILCO LADDER-UP SAFETY POST
- ㉗ 1EA. 90° VERTICAL BEND WITH 2.5" MALE FH THREAD & CAP
- ㉘ 1EA. FLANGED CAST IRON CROSS
- ㉙ 1EA. BALL VALVE
- ㉚ 2EA. FLEXIBLE COUPLING WITH STAINLESS STEEL TIE ROD & ANCHOR JOINT RESTRAINT

**SPECIAL NOTES:**

VAULT MANUFACTURER SHALL BE BROOKS, QUIKSET OR APPROVED EQUAL.  
ALL NUTS, BOLTS, & WASHERS SHALL BE 316 STAINLESS STEEL.  
SIZES PROVIDED ARE FOR 4" METER INSTALLATION. PLANS MUST BE SUBMITTED FOR THE CITY ENGINEER'S APPROVAL FOR ALL METER INSTALLATION.

APPROVED BY:  
*W.E. Cameron*  
W.E. CAMERON, CITY ENGINEER  
23764 R.C.E. NO. DATE 6-28-00



City of San Clemente  
Public Works Department - Engineering Division

MARK	REVISIONS	APPR.	DATE

3", 4", 6", 8", 10" Meter  
Installation

STD.NO.  
W-13

D:\standards\dwg\W-13.dwg 06/05/00 02:57:08 PM PDT

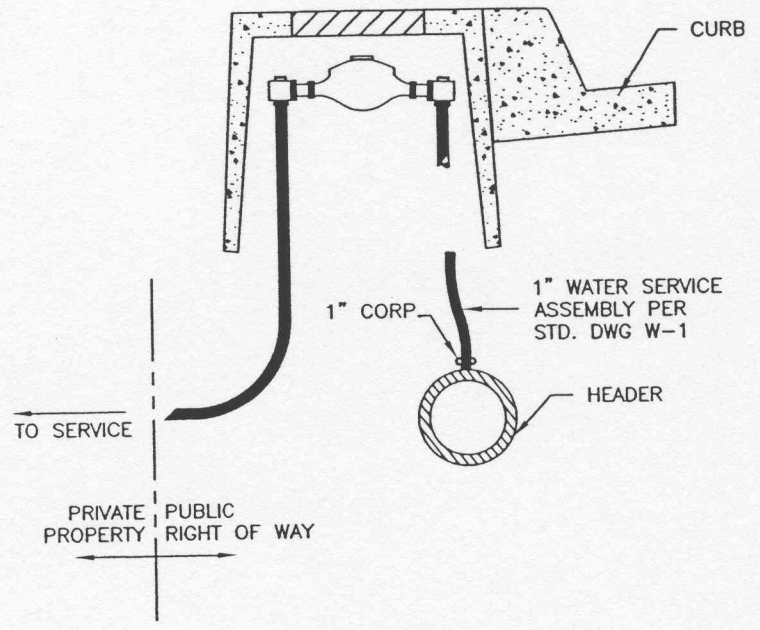
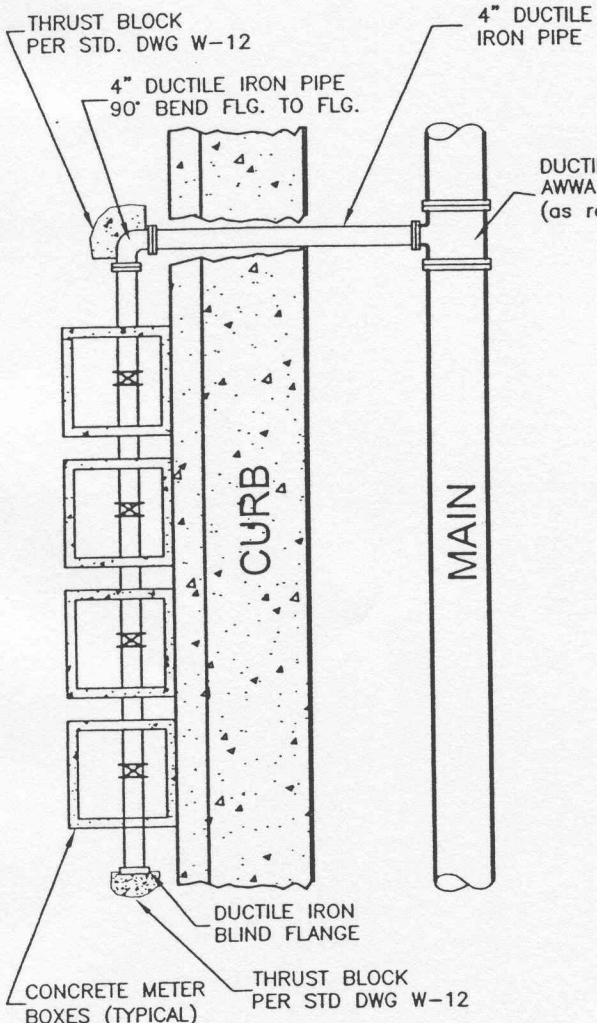

MAXIMUM FOUR (4) 1" TAPS OFF A 4" HEADER

PLAN

ELEVATION

**NOTE:**

CONCRETE METER BOXES AND WATERLINE HEADER INSTALLATION SHALL BE WITHIN THE PUBLIC RIGHT OF WAY.

D:\standards\dwg\1-4.dwg 06/07/00 04:10:47 PM PDT

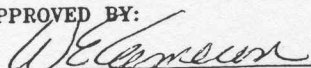
APPROVED BY:  
  
 W.E. CAMERON, CITY ENGINEER  
 23764 R.C.E. NO. 6/20/00 DATE



*City of San Clemente*  
 Public Works Department - Engineering Division

MARK	REVISIONS	APPR.	DATE

Waterline Header Installation

STD.NO.  
 W-14



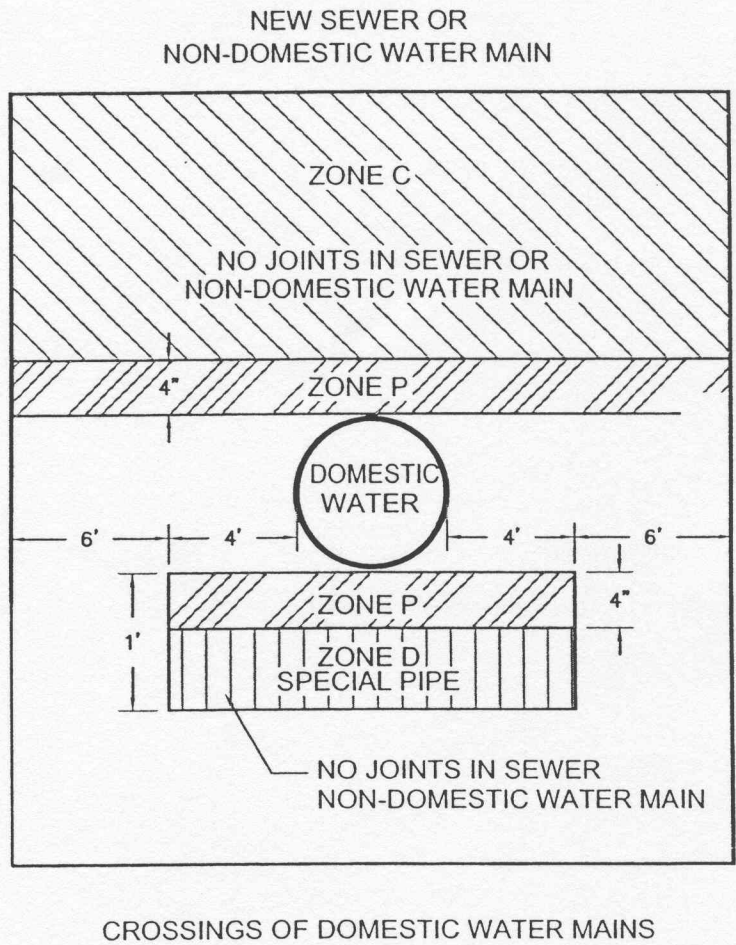
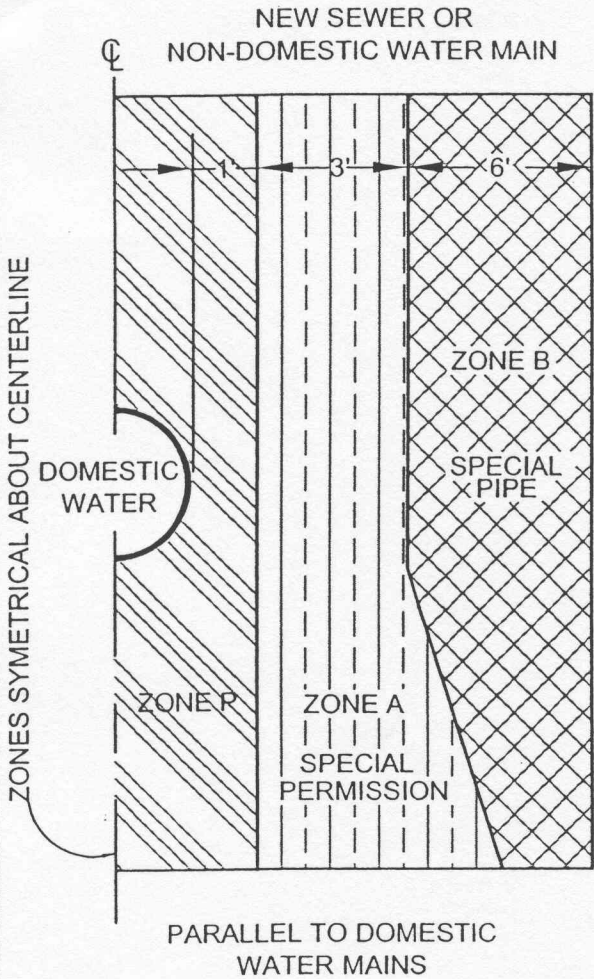

**ZONE CONSTRUCTION REQUIREMENTS FOR DOMESTIC WATER MAINS**

<b>A</b>	SPECIAL PERMISSION REQUIRED. DO NOT LOCATE ANY PARALLEL WATER MAIN IN THIS AREA WITHOUT CITY ENGINEER AND STATE HEALTH DEPARTMENT APPROVAL.
<b>B</b>	EXTRA STRENGTH VCP WITH COMPRESSION JOINTS, POLYETHYLENE LINED OR PVC SEWER PIPE WITH PUSH-ON TYPE RUBBER RING JOINTS FOR SEWER LINES. USE C900 PVC PIPE CLASS 200 OR DIP PUSH-ON TYPE RUBBER RING JOINTS FOR NON-DOMESTIC WATER MAINS.
<b>C</b>	POLYETHYLENE LINE DIP WITH MECHANICAL JOINTS, A CONTINUOUS SECTION OF C900 PVC CLASS 200 CENTERED OVER THE PIPE BEING CROSSED, OR ANY SEWER PIPE IN A 1/4" THICK CONTINUOUS STEEL CASING WITH ANNULAR SPACE PRESSURE GROUTED FOR SEWER LINES; FOR NON-DOMESTIC WATER MAINS USE ANY OF THE ABOVE WITH THE EXCEPTION THAT POLYETHYLENE LINING OF DIP IS NOT REQUIRED.
<b>D</b>	A CONTINUOUS SECTION OF POLYETHYLENE LINED DIP WITH PUSH-ON TYPE RUBBER RING JOINTS, A CONTINUOUS SECTION OF C900 PVC PIPE CLASS 200 CENTERED ON THE PIPE BEING CROSSED, ANY SEWER PIPE IN A 1/4" THICK CONTINUOUS STEEL CASING WITH ANNULAR SPACE GROUTED OR ANY SEWER PIPE SEPARATED BY A 10"x10"x4" THICK REINFORCED CONCRETE LAB; FOR NO DOMESTIC WATER MAINS USE ANY OF THE ABOVE WITH THE EXCEPTION THAT POLYETHYLENE LINING OF DIP IS NOT REQUIRED.
<b>P</b>	PROHIBITED ZONE; NO DOMESTIC WATER MAINS SECTION 64630 (e) (2) CALIFORNIA ADMINISTRATIVE CODE, TITLE 22.

D:\standards\dwg\S-1.dwg 02/17/00 04:40:09 PH PST

APPROVED BY: W.E. Cameron 23764 6/23/00  
W.E. CAMERON, CITY ENGINEER R.C.E. NO. DATE

*City of San Clemente*  
Public Works Department - Engineering Division

MARK	REVISIONS	APPR.	DATE

**Pipe Separation:**  
New Sewers from Non-Domestic Water Mains or Domestic Water Mains

STD.NO.  
**S-1**

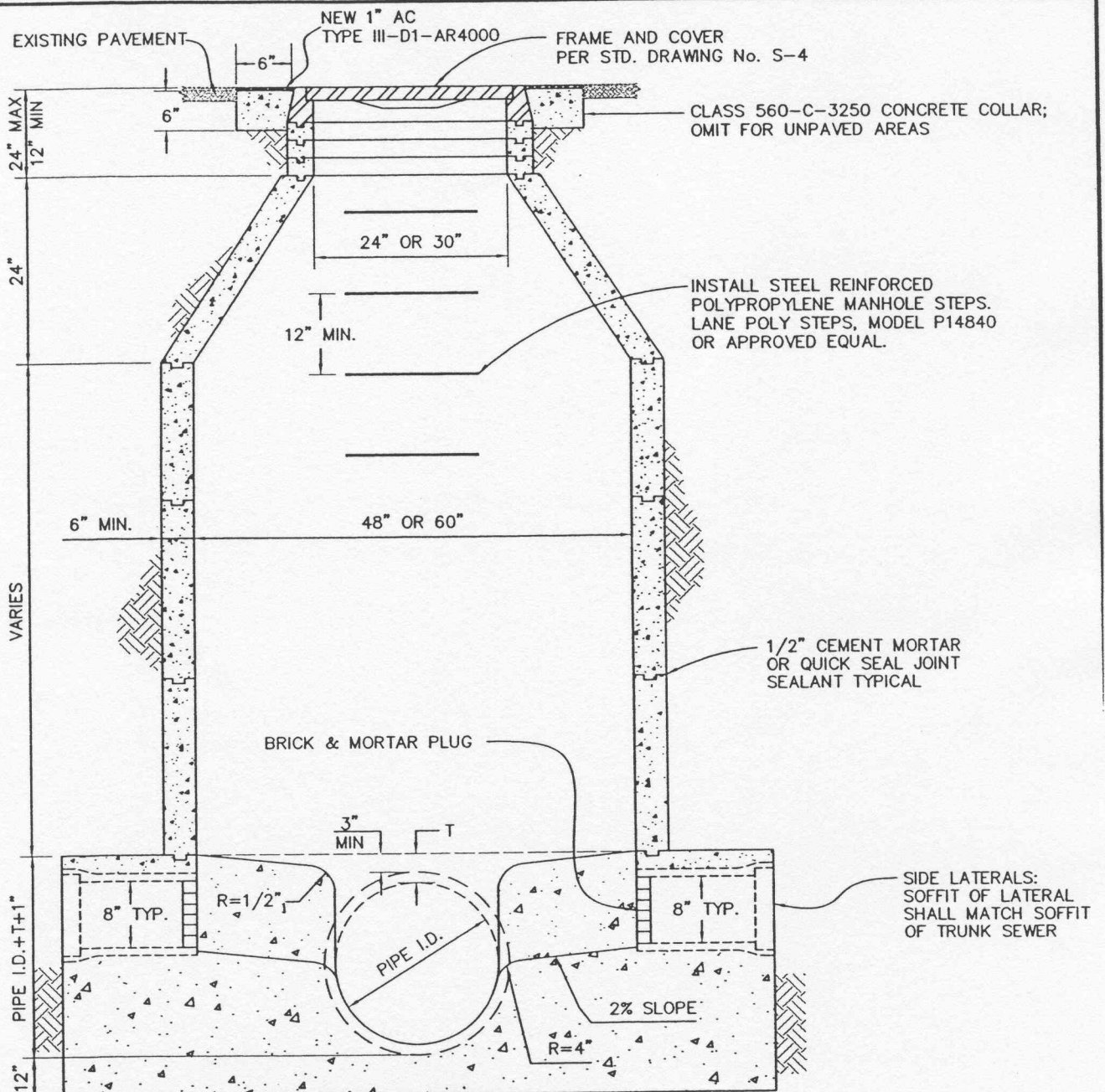

**NOTES:**

1. BASE SHALL BE CONSTRUCTED WITH TYPE V CEMENT, CLASS 560-C-3250 CONCRETE POURED TO UNDISTURBED (OR APPROVED BEDDING) SOIL. FORM CHANNELS AS DETAILED IN STANDARD DRAWING No. S-3.
2. MANHOLES PLACED IN UNPAVED AREAS SHALL HAVE FRAME AND COVER 18 INCHES ABOVE FINISH GRADE.
3. FOR SEWERS 10-INCH DIAMETER OR LESS, MANHOLE INSIDE DIAMETER SHALL BE 48 INCHES.
4. FOR SEWERS 12-INCH DIAMETER OR GREATER, MANHOLE INSIDE DIAMETER SHALL BE 60 INCHES.
5. MANHOLE DEPTHS GREATER THAN 12 FEET, SPECIAL DETAILS MUST BE SUBMITTED FOR CITY ENGINEER'S APPROVAL.

COATINGS:

- INTERIOR: 3 MILS OF EPOXY PRIMER WITH 80 MILS POLYURETHANE COAT
- EXTERIOR: 2 COAT 16 DRY MILS. KOP-COAT 300M

D:\standards\dwg\S-2.dwg 04/24/00 09:11:59 PM PDT

APPROVED BY:

*W.E. Cameron*  
**W.E. CAMERON, CITY ENGINEER**

23764 6-28-00  
**R.C.E. NO. DATE**



**City of San Clemente**  
 Public Works Department - Engineering Division

STD.NO.

**Standard Manhole**

**S-2**

MARK	REVISIONS	APPR.	DATE



PIPE SHALL BE LAID WITH END SQUARE INTO M.H. BASE, UNLESS OTHERWISE NOTED. CONSTRUCT FILLET SHELF OVER PIPE TO DRAIN

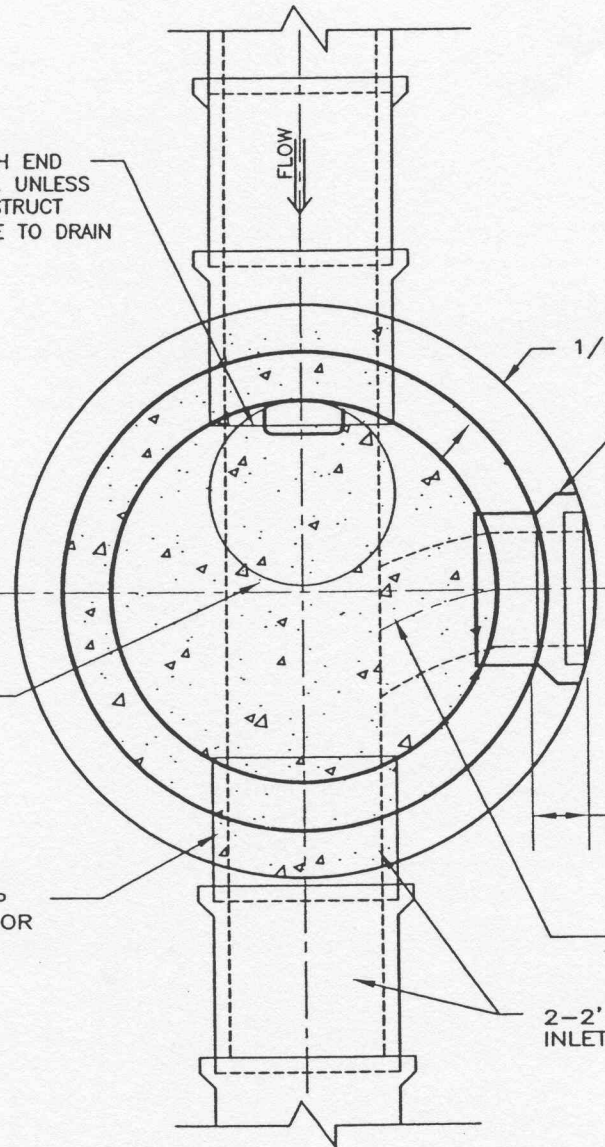

CAST IN PLACE VCP LATERALS IF REQUIRED OR PVC FITTING FOR

CENTER SHAFT OPENING OVER PIPE UPSTREAM SIDE

8" MIN. CONC. ENCASE (INCLUDING BELL)

CAST IN BASE VCP OR PVC STUB IN OR OUT AS SHOWN

R = 2D

2-2' JOINTS AT BOTH INLETS AND OUTLETS

D:\standards\dwg\9-3.dwg 02/28/00 11:18:09 AM PST

APPROVED BY:  
  
 W.E. CAMERON, CITY ENGINEER  
 23764 6-28-00  
 R.C.E. NO. DATE



*City of San Clemente*  
 Public Works Department - Engineering Division

MARK	REVISIONS	APPR.	DATE

Manhole Base Plan

STD.NO.  
 S-3

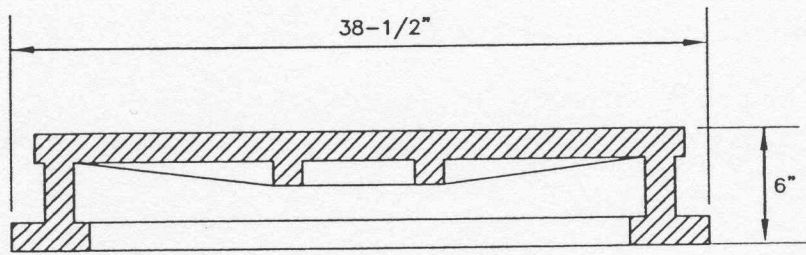
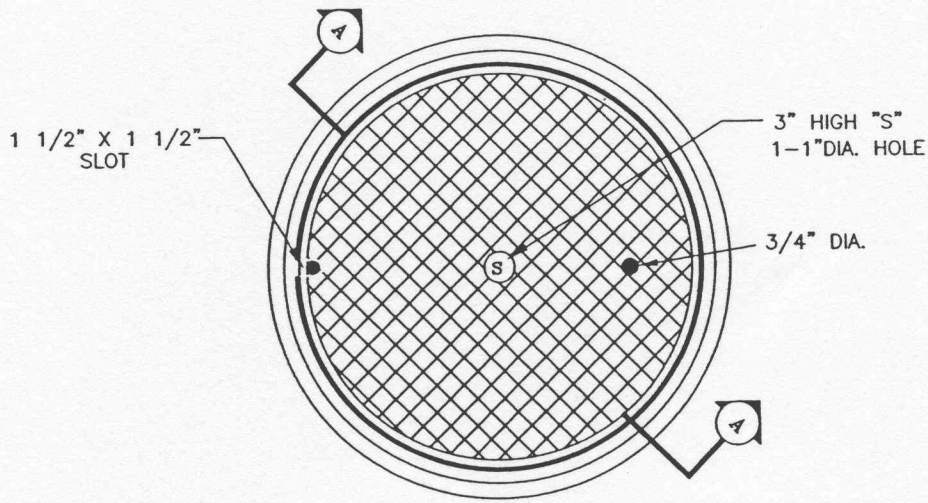

30"  
FOR 60" DIAMETER MANHOLES

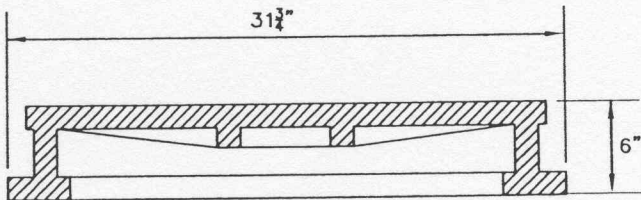

24"  
FOR 48" DIAMETER MANHOLES

SECTION "A-A"  
NOT TO SCALE

NOTES:

1. MANHOLE FRAME AND COVER SHALL BE ALHAMBRA MODEL NO. A-1499 FOR 48" DIA. MANHOLES AND MODEL NO. 1493 FOR 60" DIA. MANHOLES OR APPROVED EQUAL.
2. IF A WATER TIGHT, BOLT DOWN COVER IS REQUIRED, FURNISH ALHAMBRA MODEL NO. 1254B-6 OR APPROVED EQUAL.
3. CASTING SHALL BE DESIGNED FOR H2O LOADING AND CONFORM TO ASTM A-48 CLASS 35B IRON. CERTIFICATION OF CONFORMANCE MUST BE PROVIDED WITH DELIVERY.
4. THE CITY MAY SELECT FROM DELIVERED CASTINGS FOR TESTING CONFORMS TO ASTM A-48 CLASS 35B IRON. COST OF DELIVERY TO LABORATORY, TESTING AND REPLACEMENT CASTINGS SHALL BE BORN BY THE CONTRACTOR.
5. MANHOLE FRAME AND COVER SHALL COATED WITH ASPHALT OR BITUMINOUS PAINT.

APPROVED BY:

*W.E. Cameron*  
W.E. CAMERON, CITY ENGINEER

23764 6-28-00  
R.C.E. NO. DATE



City of San Clemente  
Public Works Department - Engineering Division

STD.NO.

Standard Manhole  
Frame and Cover

S-4

MARK	REVISIONS	APPR.	DATE



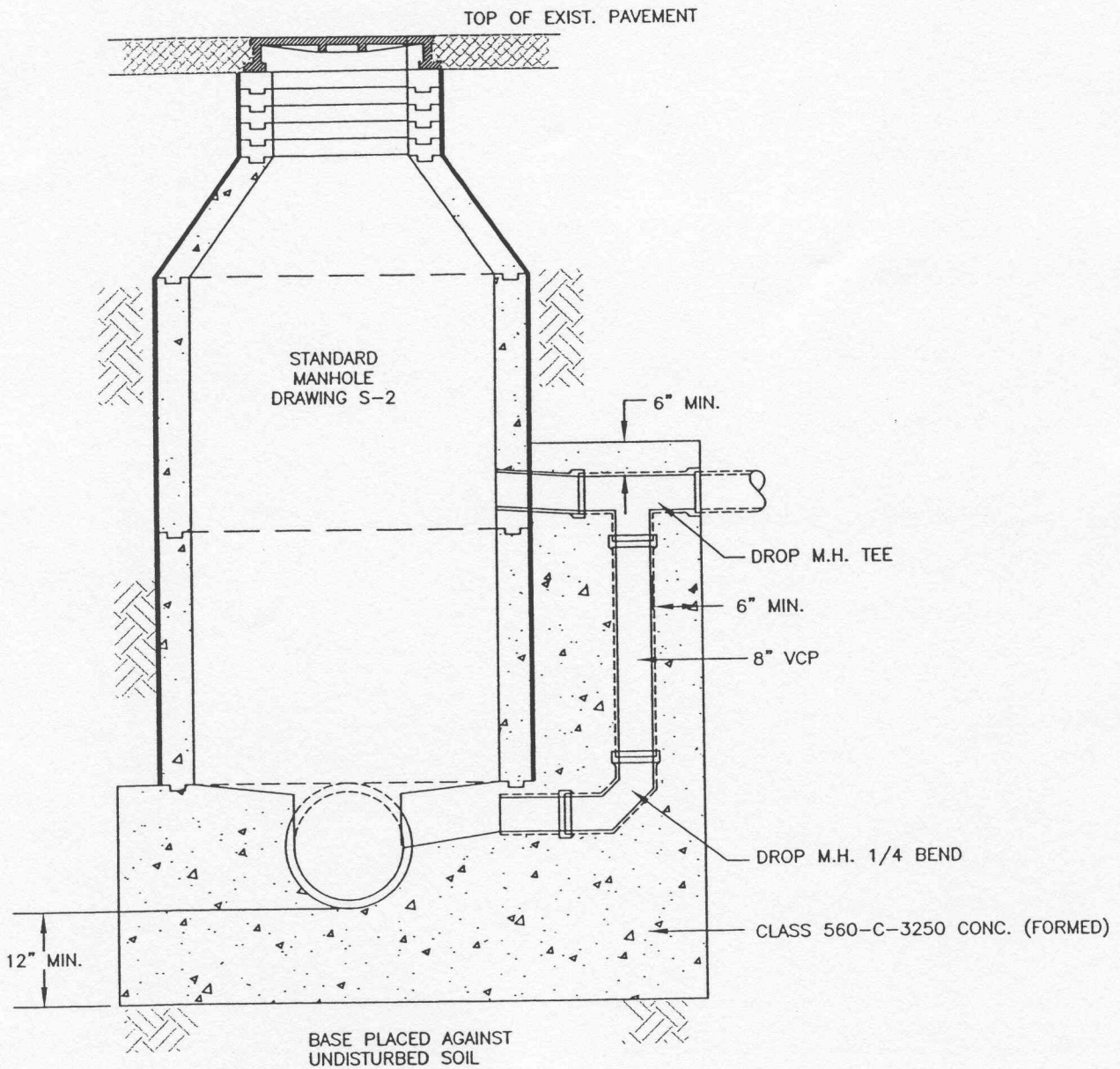

**NOTES:**

1. OPENINGS NOT PRECAST INTO MANHOLES SHALL BE MADE BY CORE DRILLING.
2. DROP MANHOLES SHALL NOT BE USED EXCEPT WHERE SLOPE OF INCOMING LATERAL EXCEEDS 10%.
3. DROP MANHOLES ARE TO BE USED ONLY UPON APPROVAL OF THE CITY ENGINEER.

D:\standards\dwg\S-5.dwg 03/08/00 07:26:02 AM PST

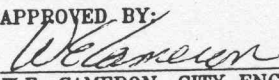
APPROVED BY:  
  
 W.E. CAMERON, CITY ENGINEER

23764 R.C.E. NO.      6-28-00 DATE



*City of San Clemente*  
 Public Works Department - Engineering Division

MARK	REVISIONS	APPR.	DATE

Drop Connection  
 to  
 Standard Manhole

STD.NO.  
 S-5

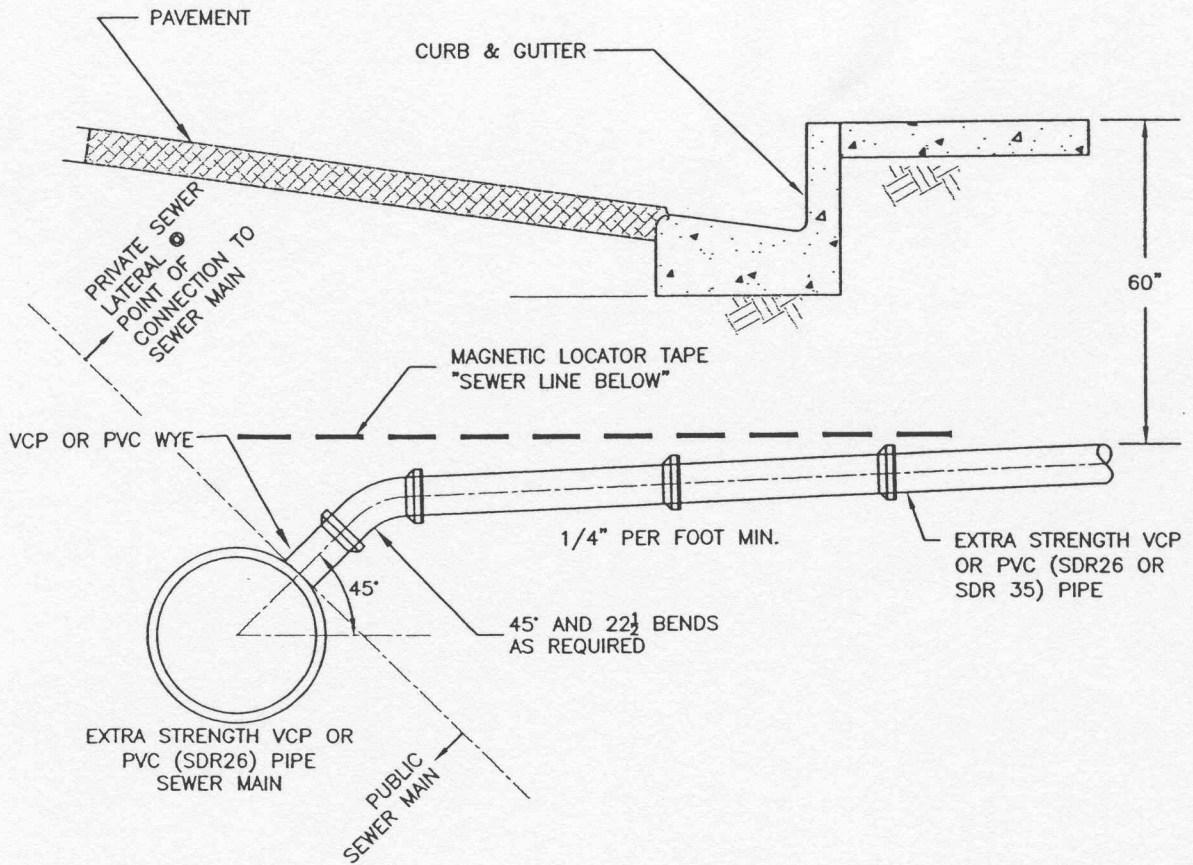

**NOTES:**

1. MARK SEWER LATERAL WITH A 2" HIGH "S" CHISELED ON TOP OF THE CURB WHERE LATERAL CROSSES UNDER THE CURB AND INSTALL MAGNETIC "CAUTION" TAPE 12 INCHES ABOVE TOP OF THE PIPE.
2. LATERAL SIZE TO BE DETERMINED BY UNIFORM PLUMBING CODE BUT NOT LESS THAN 4" DIAMETER.
3. SEE STANDARD DRAWING WS-1 FOR LATERAL AND MAINLINE BEDDING, TRENCH AND PAVEMENT REPAIR.
4. FOR WYE CONNECTION TO EXISTING MAIN, REFER TO STANDARD DRAWING S-8.

D:\standards\dwg\S-6.dwg 04/24/00 03:30:23 PM PDT

APPROVED BY: W.E. Cameron  
 W.E. CAMERON, CITY ENGINEER      23764      6-28-00  
 R.C.E. NO.      DATE



*City of San Clemente*  
 Public Works Department - Engineering Division

MARK	REVISIONS	APPR.	DATE

**House Lateral Connection**

STD.NO.  
**S-6**



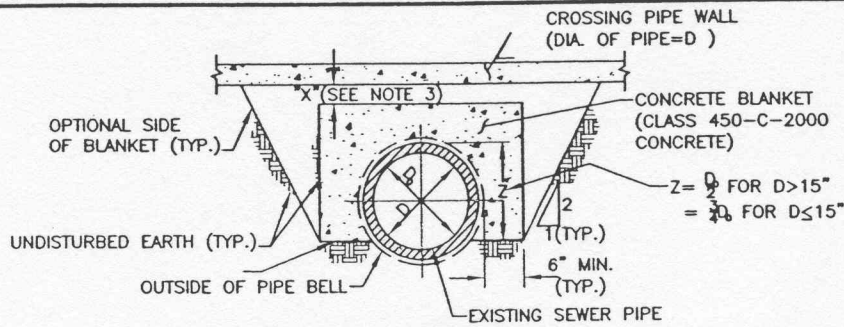

**CONCRETE BLANKET**  
(FOR EXISTING SEWER CROSSED OVER BY A NEW PIPE)

**NOTES:**

1. CONCRETE BLANKET IS REQUIRED WHEN THE CLEARANCE BETWEEN THE TOP OF THE EXISTING PIPE AND THE BOTTOM OF THE CROSSING PIPE IS LESS THAN 18".
2.  $\gamma = D/6$  (6" MIN.) WHERE THE CLEARANCE BETWEEN THE TOP OF THE EXISTING PIPE AND THE BOTTOM OF THE CROSSING PIPE IS LESS THAN  $\gamma$ , THE CONCRETE SHALL BE PLACED BETWEEN THE PIPES AND AROUND THE SIDES OF THE CROSSING PIPE UP TO A LEVEL EQUAL TO  $\gamma$  ABOVE THE EXISTING PIPE, OR AS REQUIRED BY NOTE 3 BELOW, WHICHEVER IS HIGHER.
3.  $x = \frac{D}{2}$ , MINIMUM, TO PROVIDE BEDDING MATERIAL FOR THE CROSSING CONDUIT. WHEN "X" IS LESS THAN THIS MINIMUM, THE ENTIRE TOP SURFACE OF THE BLANKET SHALL BE RAISED TO MAKE CONTACT WITH THE LOWER 90° OF THE CROSSING PIPE.
4. THE BLANKET SHALL EXTEND LONGITUDINALLY TO THE FIRST JOINT BEYOND THE TRENCH EXCAVATION AT EACH END OF THE BLANKET, EXCEPT THAT THE BLANKET NEED NOT BE EXTENDED MORE THAN 4 FEET BEYOND THE TRENCH.
5. WHENEVER A PIPE BELL IS ENCOUNTERED WITHIN THE LIMITS OF THE BLANKET, ALL DIMENSIONS SHALL REFER TO THE BELL.

**REINFORCED CONCRETE BEAM (DIMENSIONS AND REINFORCEMENT)**

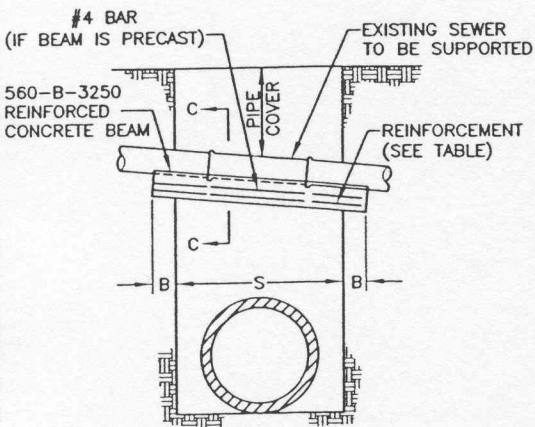

**SUPPORTS FOR SEWER ACROSS TRENCHES**

MIN. BEARING SHALL BE 0.5 O.D. OF SUPPORTED PIPE

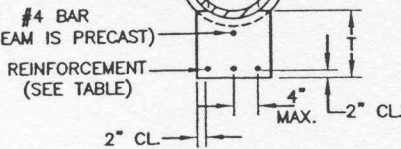

**SECTION C-C**

S	PIPE COVER														
	0' to 8'-0"			8'-1" to 12'-0"			12'-1" to 16'-0"			16'-1" to 20'-0"			20'-1" to 25'-0"		
	T	BARS	B	T	BARS	B	T	BARS	B	T	BARS	B	T	BARS	B
0' to 4'-0"	8"	#4	1'-6"	8"	#4	1'-6"	9"	#4	1'-6"	10"	#4	1'-6"	10½"	#4	1'-6"
4'-1" to 5'-0"	8"	#4	1'-6"	9½"	#4	1'-6"	11"	#4	1'-6"	12"	#4	1'-6"	12½"	#5	1'-6"
5'-1" to 6'-0"	9"	#4	1'-6"	11"	#5	1'-6"	12½"	#5	1'-6"	13½"	#5	2'-0"	14½"	#5	2'-0"
6'-1" to 7'-0"	10"	#5	1'-6"	12½"	#5	2'-0"	14½"	#5	2'-0"	15½"	#5	2'-0"	16½"	#5	2'-0"
7'-1" to 8'-0"	11"	#5	1'-6"	14"	#5	2'-0"	16"	#5	2'-0"	17½"	#5	2'-6"	19"	#6	2'-6"
8'-1" to 9'-0"	12½"	#5	2'-0"	15½"	#6	2'-6"	17½"	#6	2'-6"	19½"	#6	2'-6"	21"	#6	2'-6"
9'-1" to 10'-0"	13½"	#6	2'-0"	17"	#6	2'-6"	19½"	#6	3'-0"	21½"	#6	3'-0"	23"	#6	3'-0"
10'-1" to 11'-0"	14½"	#6	2'-6"	18½"	#6	3'-0"	21"	#6	3'-0"	23½"	#6	3'-0"	25"	#7	3'-0"
11'-1" to 12'-0"	15½"	#6	2'-6"	20"	#6	3'-0"	23"	#7	3'-6"	25½"	#7	3'-6"	27"	#7	3'-6"
12'-1" to 13'-0"	17"	#6	3'-0"	21½"	#7	3'-6"	24½"	#7	3'-6"	27½"	#7	4'-0"	29"	#7	4'-0"
13'-1" to 14'-0"	18"	#7	3'-0"	23"	#7	3'-6"	26½"	#7	4'-0"	29½"	#7	4'-0"	31½"	#7	4'-0"
14'-1" to 15'-0"	19"	#7	3'-0"	25"	#7	4'-0"	28"	#7	4'-0"	31½"	#7	4'-6"			
15'-1" to 16'-0"	20½"	#7	3'-6"	26½"	#7	4'-0"	30"	#8	4'-6"						
16'-1" to 17'-0"	21½"	#7	3'-6"	28"	#8	4'-6"									
17'-1" to 18'-0"	22½"	#8	4'-0"	29½"	#8	4'-6"									

**NOTES:**

1. WIDTH OF BEAM SHALL EQUAL O.D. OF SUPPORTED PIPE. MINIMUM WIDTH SHALL BE 6".
2. IF SUPPORTED PIPE IS BEDDED IN CONCRETE, BEAM WIDTH SHALL EQUAL BEDDING WIDTH.
3. IF BEAM IS PRECAST, ENDS OF BEAM SHALL BE FULLY BEDDED IN 450-C-2000 CONCRETE FOR LENGTH "B", THE BEDDING SHALL HAVE A MINIMUM THICKNESS OF 4", CLASS "C" MORTAR SHALL BE PLACED BETWEEN TOP OF BEAM AND SUPPORTED PIPE TO PROVIDE MINIMUM BEARING SHOWN.
4. THIS CASE IS PERMITTED ONLY IF THE TRENCH WALLS ARE FIRM AND UNYIELDING.
5. MAXIMUM SPACING OF BARS SHALL BE 4" O.C.

APPROVED BY:

*W.E. Cameron*  
W.E. CAMERON, CITY ENGINEER

23784 628-0  
R.C.E. NO. DATE



**City of San Clemente**  
Public Works Department - Engineering Division

MARK	REVISIONS	APPR.	DATE

**Pipe Support of Perpendicular Crossing**

STD. NO.  
**S-7**

D:\standard\dwg\S-7.dwg 03/08/00 07:43:18 AM PST

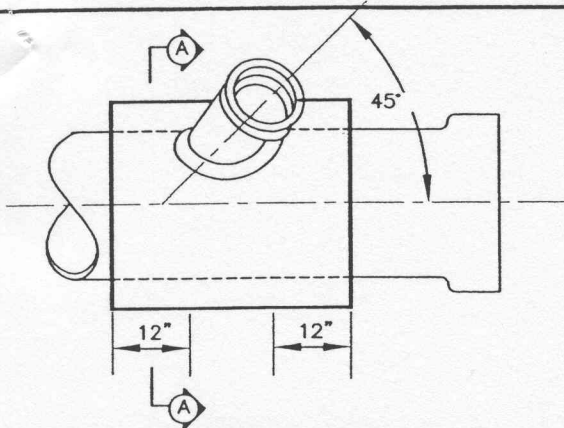

**SEWER SADDLE WYE**  
NOT TO SCALE

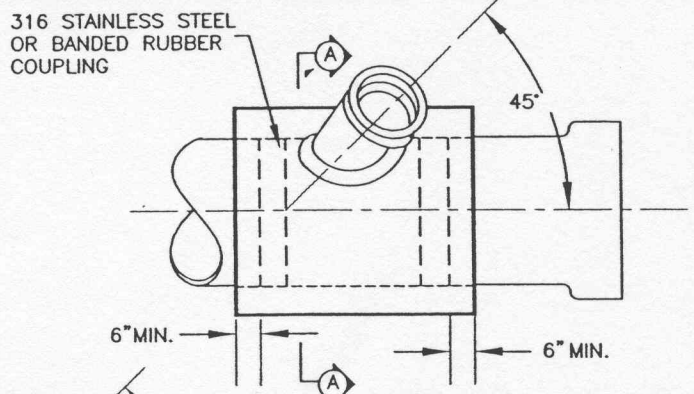

**CUT IN WYE**  
NOT TO SCALE

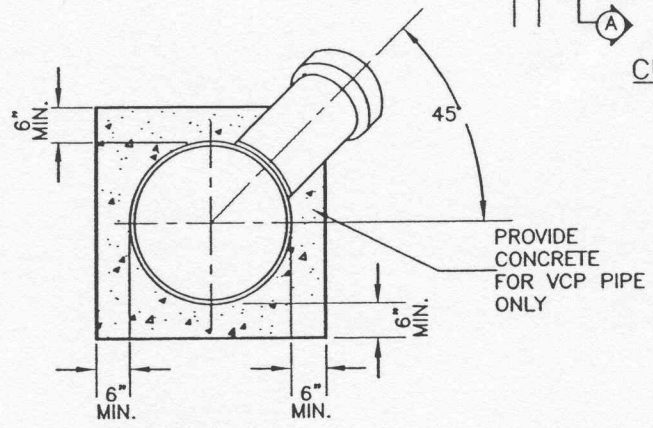

**SECTION A-A**  
NOT TO SCALE

**NOTES:**

1. CONNECTION TO BE MADE AT APPROXIMATELY CENTER OF JOINT LENGTH.
2. THE HOLE FOR SEWER SADDLE WYE SHALL BE MADE WITH A TAPPING MACHINE. THE HOLE SHALL BE CLEANLY MACHINED AND IF NECESSARY WORKED BY HAND WITH RASP, OR SANDED TO ACCOMPLISH A TRUE AND NEAT OPENING FOR THE SEWER SADDLE WYE.
3. THE SEWER SADDLE WYE FOR PVC PIPE SHALL BE MANUFACTURED BY J-M PIPE OR APPROVED EQUAL. A RUBBER GASKET SHALL BE INSTALLED AND BANDED WITH TWO(2) STAINLESS STEEL HOSE CLAMPS.
4. THE SADDLE WYE CONNECTION FOR VCP PIPE AND CUT-IN WYE CONNECTION FOR VCP & PVC PIPE SHALL BE ENCASED WITH CLASS 560C-C-3250 CONCRETE AFTER THE CONNECTION IS APPROVED BY THE INSPECTOR TO THE LIMITS INDICATED ABOVE. THE BELL ON THE LATERAL SHALL NOT BE ENCASED.
5. ALL CHIPS, DIRT, EPOXY, MORTAR, AND CONCRETE SHALL BE KEPT OUT OF THE SADDLED SEWER, AND CLEANING AND BALLING OF THE SADDLED REACH SHALL BE PRE FORMED IF SO ORDERED BY THE INSPECTOR.
6. ANY DAMAGED PIPE SHALL BE REPAIRED OR REPLACED AS DIRECTED BY THE INSPECTOR.
7. SEWER SADDLE WYE TO BE USED WHEN LATERAL IS 4" OR 6" IN DIAMETER. FOR 8" LATERAL AND OVER, A STANDARD MANHOLE CONNECTION IS REQUIRED.
8. FOR A 6" SEWER LATERAL, SADDLE CONNECTION SEWER MAIN SHALL BE 10" MINIMUM OR LARGER. IF SEWER MAIN IS SMALLER THAN 10", SEWER CUT-IN CONNECTION SHALL BE PROVIDED.
9. CONNECTION OF SEWER MAIN AND REQUIRED PROCEDURE:
  - A. CONTACT CITY ENGINEER TO DETERMINE THE LOCATION AND SIZE SUITABILITY OF AN EXISTING SERVICE WYE. IF A WYE IS DEEMED SUITABLE IT MUST BE UTILIZED.
  - B. IF NO SUITABLE EXISTING WYE IS AVAILABLE, A VCP OR PVC SEWER SADDLE WYE MUST BE CONSTRUCTED IN THE SEWER MAIN.
  - C. BREAKING AND MORTARING IS PROHIBITED.

D:\standards\dwg\S-B.dwg 04/24/00 04:40:20 PM PDT

APPROVED BY: *W.E. Cameron*  
 W.E. CAMERON, CITY ENGINEER      23764      6-28-00  
 R.C.E. NO.      DATE



**City of San Clemente**  
 Public Works Department - Engineering Division

MARK	REVISIONS	APPR.	DATE

**Sewer Saddle Wye & Cut-In Wye Connection for Sewer Laterals**

STD.NO.  
**S-8**



LAMPHOLE COVER AND FRAME  
FOR SEWER LINE INSPECTION AND EXAMINATION

PLATE NUMBER M-1240	CLEAR OPENING 10	OVERALL BASE 15	HEIGHT FRAME 12	APPROX. WEIGHT 110
------------------------	---------------------	--------------------	--------------------	-----------------------

PAINTED: BITUMINOUS PAINT.

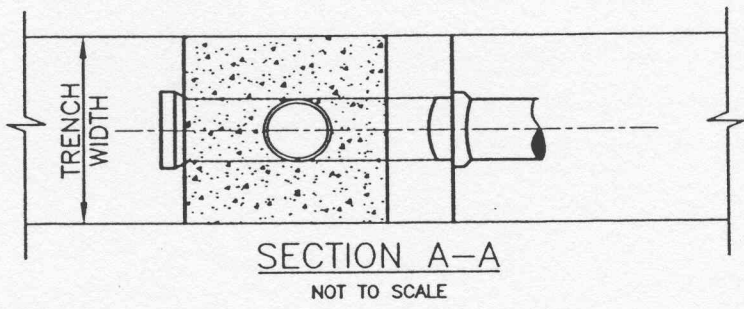
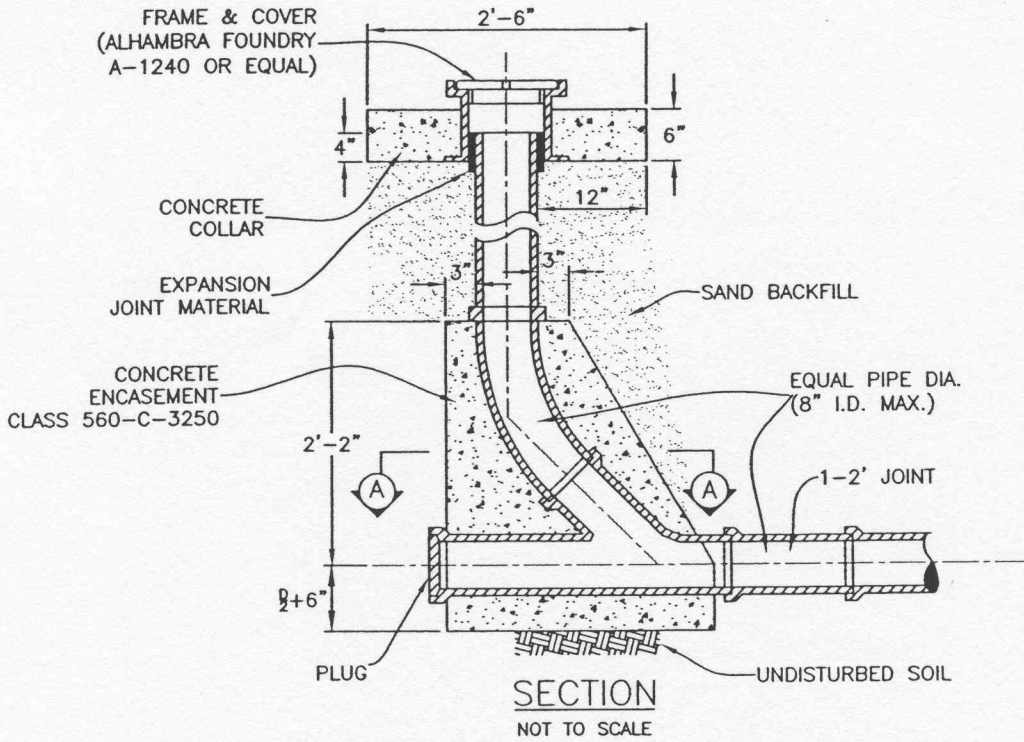
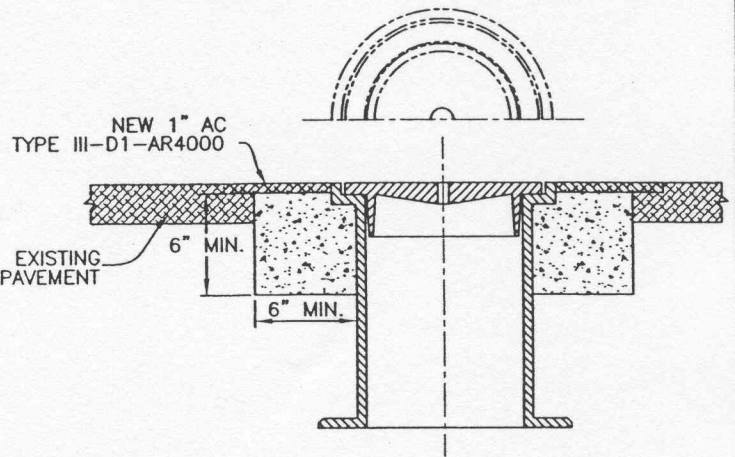

**NOTES:**  
CONSTRUCTION OF CLEAN OUTS MUST BE APPROVED FROM THE CITY ENGINEER.

APPROVED BY:  
*W.E. Cameron*  
W.E. CAMERON, CITY ENGINEER

23764 628-02  
R.C.E. NO. DATE



*City of San Clemente*  
Public Works Department - Engineering Division

MARK	REVISIONS	APPR.	DATE

Clean Out Detail

STD.NO.  
S-9

D:\standards\dwg\S-9.dwg 05/01/00 09:34:27 AM PDT

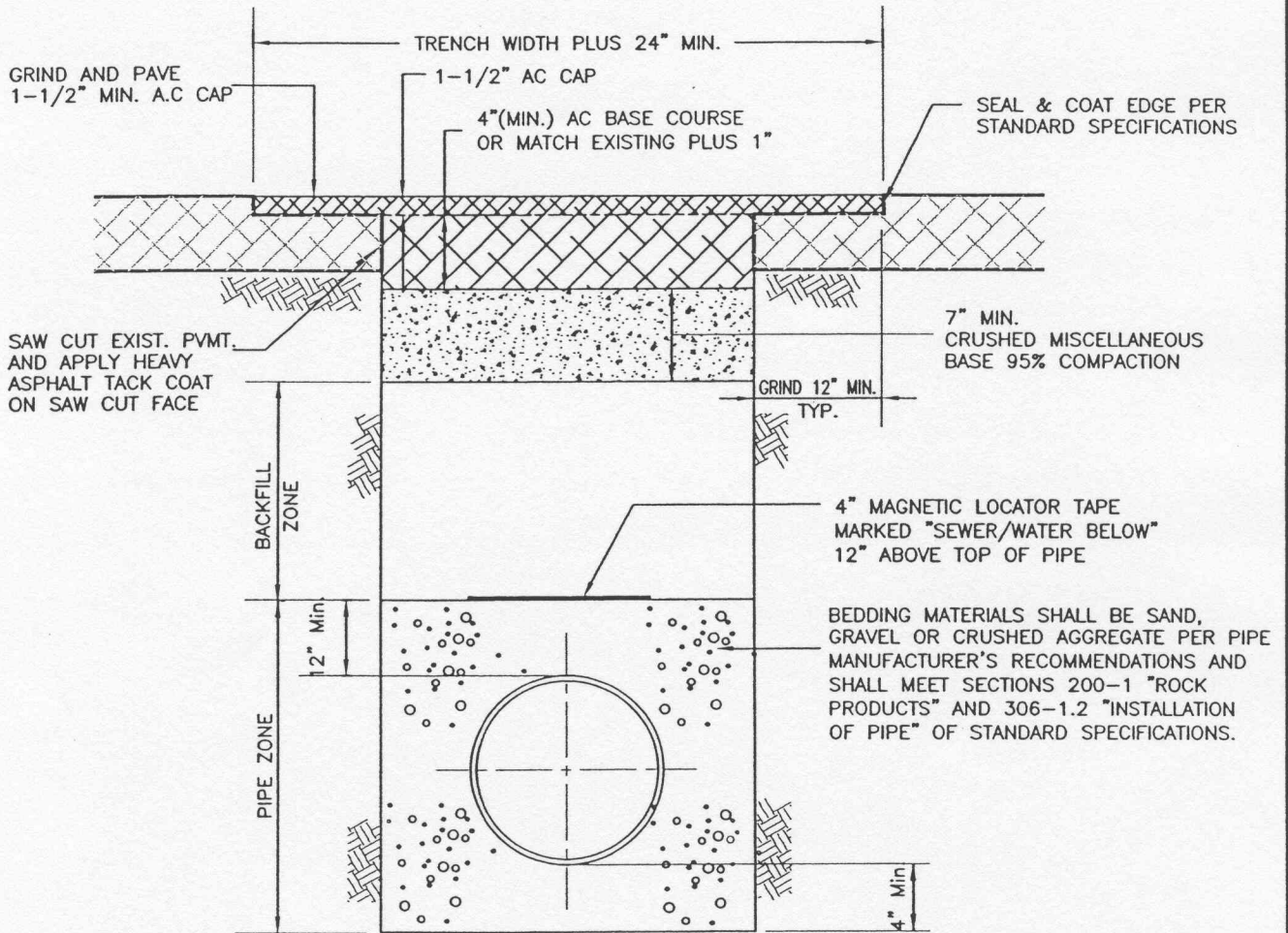

**NOTES:**

1. ALL TRENCHING AND BACKFILL SHALL BE DONE IN ACCORDANCE WITH SECTION 306, STANDARD SPECIFICATIONS, EXCEPT THAT THE BACKFILL ZONE SHALL BE COMPACTED TO A MINIMUM 90% COMPACTION.
2. IF THE EDGE OF THE TRENCH IS WITHIN 3 FT. OF THE GUTTER, GRIND AND PAVE ALL THE WAY TO EDGE OF THE GUTTER.
3. TRENCHES ON COLLECTOR AND ARTERIAL STREETS SHALL BE GROUND FULL WIDTH OF A TRAVEL LANE.
4. A.C. CAP SHALL BE PLACED NO LATER THAN 5 WORKING DAYS AFTER BASE COURSE. APPLY TACK BEFORE PLACING A.C. CAP.
5. A.C. BASE COURSE SHALL BE TYPE III, B2-AR4000, A.C. CAP SHALL BE TYPE III, C3-AR4000.

D:\standards\dwg\WS-1.dwg 05/01/00 04:21:30 PM PDT

APPROVED BY:

*W.E. Cameron*  
**W.E. CAMERON, CITY ENGINEER**

23764 6-28-02  
**R.C.E. NO. DATE**



*City of San Clemente*  
**Public Works Department - Engineering Division**

MARK	REVISIONS	APPR.	DATE

**Pipe Bedding,  
Trench Backfill  
and Roadway Repair**

STD.NO.  
**WS-1**



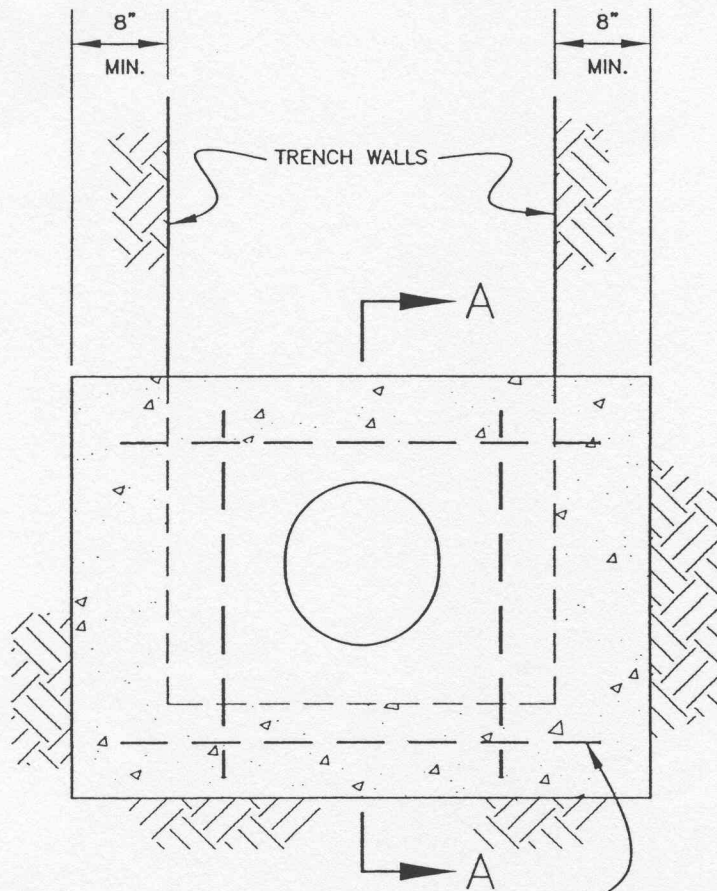

#4 BARS (4 REQ'D.)

ELEVATION

NOT TO SCALE

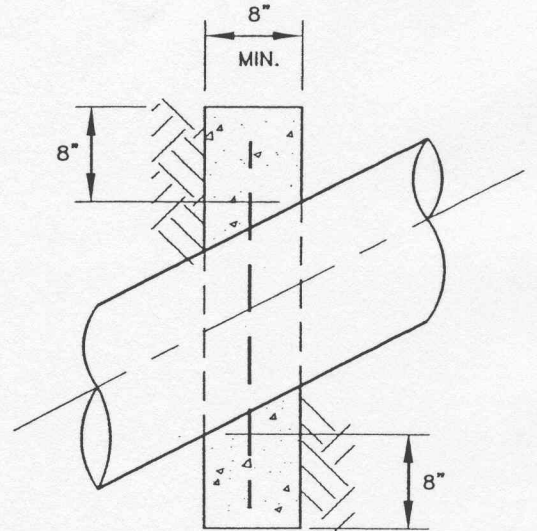

SECTION A-A

NOT TO SCALE

**NOTES:**

1. CLASS 560-C-3250 PIPE ANCHOR BLOCKS SHALL BE INSTALLED ON ALL WATER, SEWER OR RECLAIMED WATER WHERE SLOPE EXCEEDS 30%.
2. SPACING SHALL BE AS DIRECTED BY THE CITY ENGINEER.

D:\standards\dwg\WS-2.dwg 03/08/00 07:52:06 AM PST

APPROVED BY:

*W.E. Cameron*  
W.E. CAMERON, CITY ENGINEER

23764 6-28-00  
R.C.E. NO. DATE



*City of San Clemente*  
Public Works Department - Engineering Division

MARK	REVISIONS	APPR.	DATE

Anchor Block for Pipes  
Installed in Slopes  
Greater Than 30%

STD.NO.  
WS-2

STEEL CASING			
NOMINAL CARRIER PIPE SIZE	CASING SIZE	MIN. WALL THICKNESS	SKID
4"	10" I.D.	1/4"	REDWOOD UNFINISHED
6"	12" I.D.	1/4"	
8"	16" I.D.	1/4"	
10"	18" I.D.	5/16"	
12"	20" I.D.	5/16"	

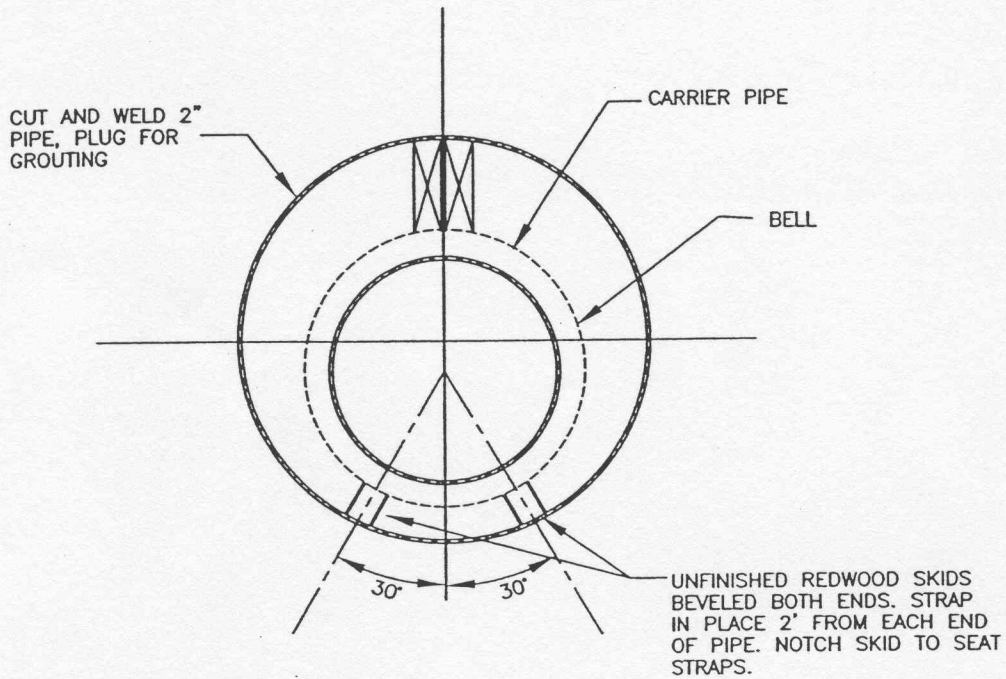

**NOTES:**

1. CASING SHALL BE INSTALLED BY BORING OR JACKING.
2. REDWOOD SHALL BE PROVIDED AS PER DETAIL ABOVE. SKIDS MUST PREVENT BEARING ON CASING, AND MOVEMENT OF CARRIER PIPE.
3. CASING SECTIONS TO BE JOINED BY CONTINUOUS WELD.
4. EACH END OF CASING SHALL BE SEALED WITH CONCRETE OR APPROVED FLEXIBLE SEAL.
5. CASING TO BE FILLED WITH AIR BLOWN SAND OR GROUT AS APPROVED BY THE CITY ENGINEER.

D:\standards\dwg\WS-3.dwg 03/08/00 07:59:09 AM PST

APPROVED BY: <i>W. E. Cameron</i> W. E. CAMERON, CITY ENGINEER		23764 R.C.E. NO.	6-28-00 DATE
MARK	REVISIONS	APPR.	DATE



**City of San Clemente**  
Public Works Department - Engineering Division

Pipe Casing

STD.NO.  
WS-3