

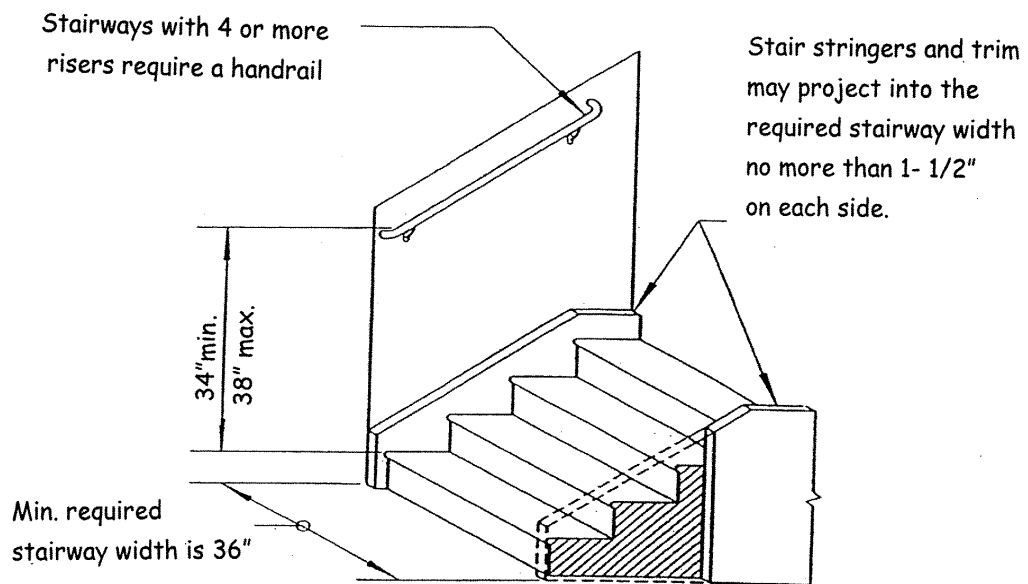

Residential Basic Stairs & Handrail Detail

BI-13

These illustrations apply to private residential stairways only.



TYPICAL STAIR ELEVATION

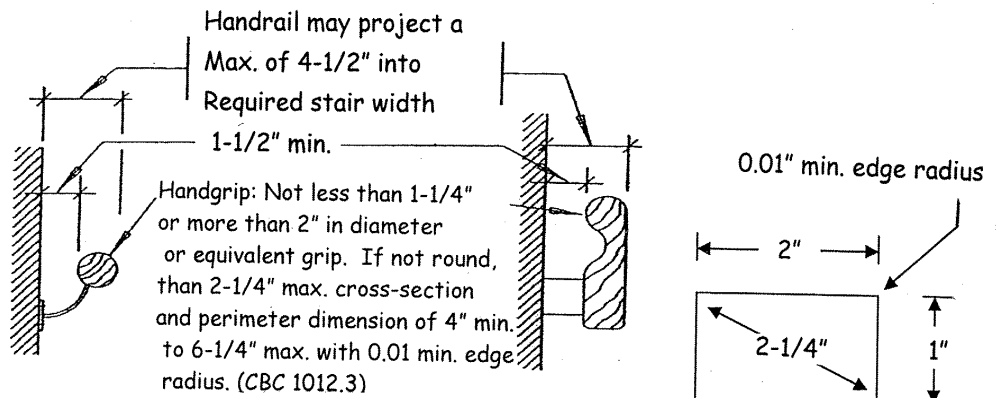

TYPICAL HANDRAIL DETAILS

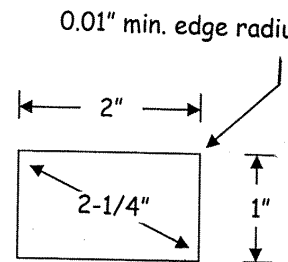

HANDGRIP EXAMPLE

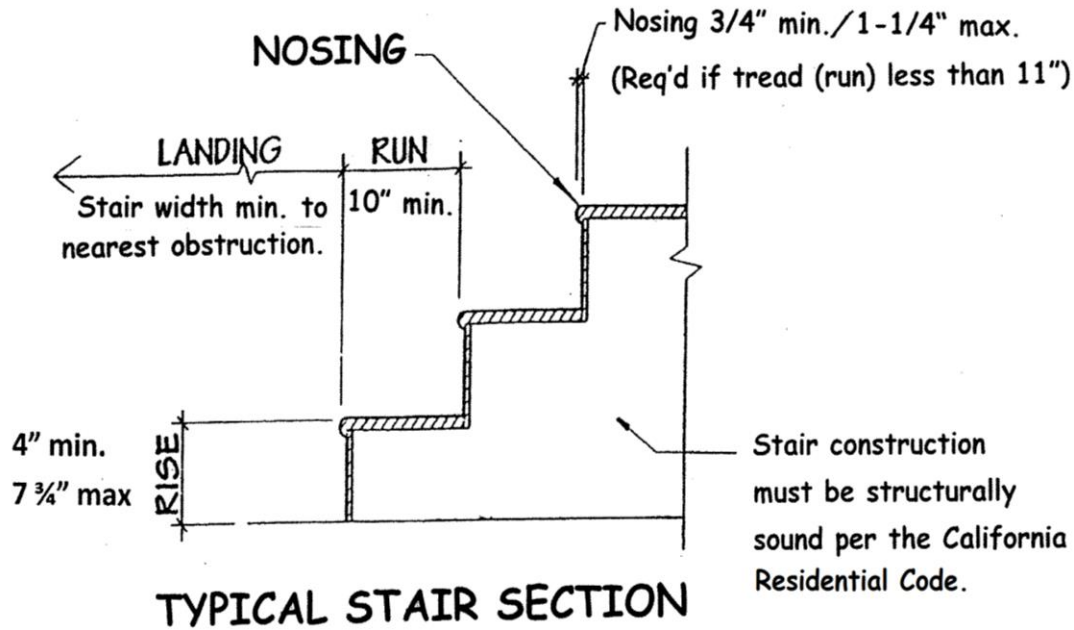

NOTES:

1. These regulations apply to private residential stairways only. Refer to the 2019 Edition of the California Building Code for the construction of stairs other than private residential.
2. For exceptions related to the construction of winding, circular or spiral stairs, see the 2019 Edition of the California Residential Code.
3. The largest rise or run within any flight of stairs shall not exceed the smallest by more than 3/8".
4. Stair nosing shall be 3/4" min./1-1/4" max. where tread depth is less than 11".
5. A landing extending the width of the stair is required at the top and bottom of every stairway.
6. If an intermediate landing is provided, the depth of such shall be equal to or greater than the required width of the stair in which it occurs.

HANDRAILS REQUIRED
ALL STAIRS /WALKWAYS CONTAINING
3 OR MORE STEPS (4 RISERS) REQUIRE
HANDRAILS TO BE INSTALLED

