

ENGINEERING DIVISION

TECHNICAL STANDARDS



Updated February 2021

TABLE OF CONTENTS

<u>STD. NO</u>	<u>STREET STANDARD DRAWINGS</u>
ST-1	Type I Access Ramp
ST-2	Type II Access Ramp
ST-3	Sidewalks
ST-4	Interlocking Paver Sidewalk
ST-5	Tile Sidewalk
ST-5A	“Ole Hanson” Replica Tile Sidewalk (Arto Brick Tile)
ST-6	Curbs and Gutters
ST-7	Curb Drain
ST-8	Cross and Longitudinal Gutters
ST-9	Residential Driveway Approach
ST-10	Commercial & Industrial Driveway Approach
ST-11	Driveway Grades
ST-12	Parking Circulation
ST-13	Parking Aisles and Driveways
ST-14	Parking Spaces Backing into Alley
ST-15	Parking Standards
ST-16	A.D.A. Parking Standards
ST-17	Street Name Signs
ST-18	Traffic Sign Locations
ST-19	Street Light Standards
ST-20	Standard Street Sections
ST-21	Continental Crosswalk
ST-22	Alley Intersection Detail
ST-23	Longitudinal Alley Gutter Detail
ST-24	Longitudinal Alley Gutter at Manhole

STANDARD GENERAL NOTES

Erosion Control
Grading Plans
Sewer Systems
Storm Drain Plans
Street Improvements Plans
Street Lighting
Striping
Traffic Control Plans
Water Systems

DIGITAL SUBMISSIONS REQUIREMENTS

Digital submissions requirements

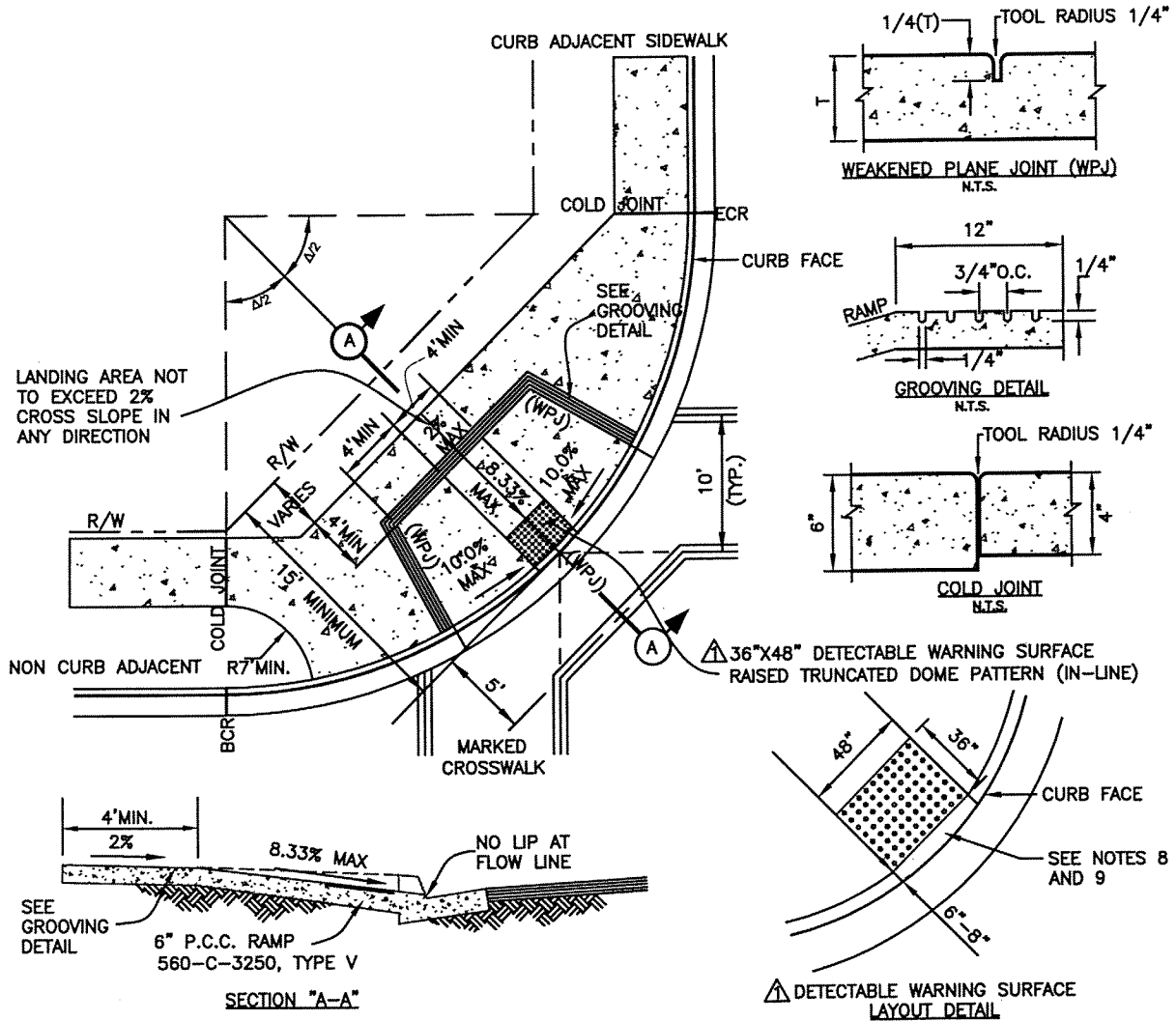

- NOTES:**
1. RAMP SHALL HAVE A 12" WIDE BORDER ON FLAT SURFACE WITH 1/4" GROOVES APPROXIMATELY 3/4" O.C. AS SHOWN IN GROOVING DETAIL.
 2. RAMPS SHALL HAVE TRANSVERSE BROOM FINISH TEXTURE ROUGHER THAN THE SURROUNDING SIDEWALK.
 3. RAMP GRADES SHALL BE STAKED FOR INSPECTION PRIOR TO PLACEMENT OF CONCRETE.
 4. CURB RETURN RADII SHALL BE AS SHOWN ON APPROVED PLANS.
 5. CONCRETE THICKNESS SHALL BE 6 INCHES ON NATIVE FROM ECR TO BCR (4" C.A.B. SHALL BE USED AS REQUIRED BY THE CITY ENGINEER).
 6. CURB RAMPS SHALL HAVE DETECTABLE WARNING SURFACE THAT EXTENDS THE FULL WIDTH AND 3' DEPTH OF THE RAMP. DETECTABLE WARNING SURFACES SHALL BE MINIMUM 36"x48", DARK GREY COLOR, CAST-IN-PLACE TILES MANUFACTURED BY ARMOR TILE TACTILE SYSTEMS OR APPROVAL EQUAL SUPPLIERS INCLUDE WHITE CAP CONSTRUCTION SUPPLY IN SAN JUAN CAPISTRANO, SANTA ANA, SAN DIEGO, AND RIVERSIDE.
 - * FOR ADA COMPLIANT CURB RAMPS, SURFACE-APPLIED ARMOR TILES MAY BE USED IN-LIEU OF THE CAST-IN-PLACE TILES TO RETROFIT THE RAMP WITH DETECTABLE WARNING SURFACE. APPROVAL FROM THE CITY ENGINEER OR DESIGNEE IS REQUIRED PRIOR TO THE INSTALLATION OF SURFACE-APPLIED ARMOR TILES.
 7. INSTALLATION REQUIREMENTS FOR CAST-IN-PLACE DETECTABLE WARNING TILES SHALL CONFORM TO MANUFACTURE'S SPECIFICATIONS.
 8. FOR CORNER ACCESS RAMPS, CONCRETE BETWEEN DETECTABLE WARNING SURFACE AND CURB SHALL BE POURED MONOLITHIC WITH THE CURB & GUTTER.
 9. THE EDGE OF THE DETECTABLE WARNING SURFACE NEAREST THE STREET SHALL BE BETWEEN 6" AND 8" FROM CURB FACE.

CLand Projects 2005\Standard Dwg\Technical Std Dwg\ST-1.dwg 10/31/2006 4:09:33 PM PST

APPROVED BY: *W.E. Cameron*
 W.E. CAMERON, CITY ENGINEER 23764 7-16-06
 R.C.E. NO. DATE



City of San Clemente
 Public Works Department - Engineering Division

▲	ADDED DETECTABLE WARNING SURFACE	WEC	8-31-06
▲	ADDED DETECTABLE WARNING SURFACE FOR RETROFIT CURB RAMPS	WEC	11-8-06
MARK	REVISIONS	APPR.	DATE

Type I Access Ramp		STD.NO. ST-1
--------------------	--	-----------------

MINIMUM RAMP LENGTH (L) AT BACK OF SIDEWALK		
	6" CURB FACE	8" CURB FACE
"L"	6'-0" MIN.	8'-0" MIN.

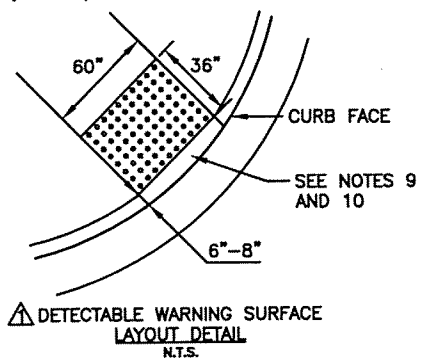
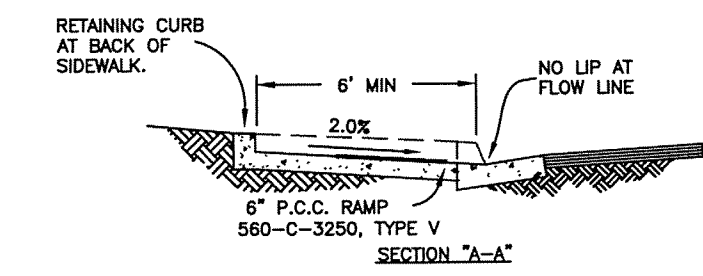
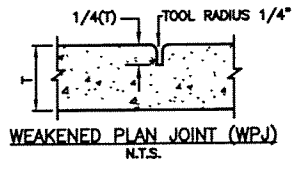
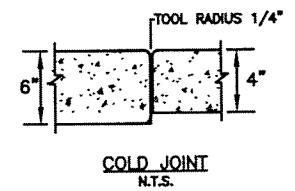
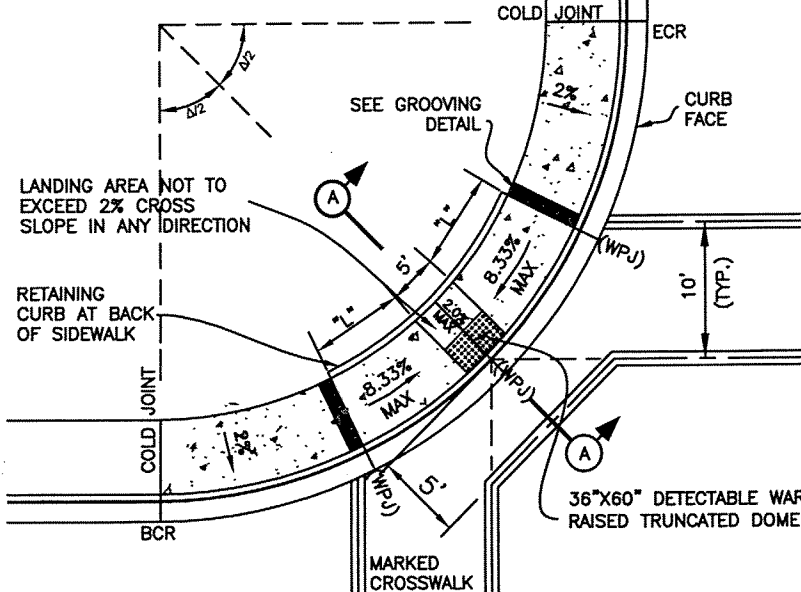
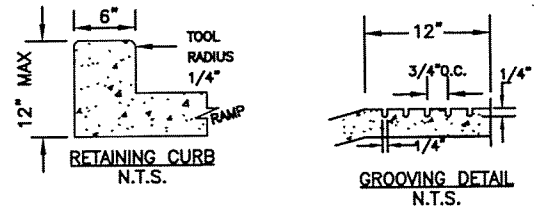

NOTES:

1. TYPE II ACCESS RAMP MAY ONLY BE USED WHERE EXISTING RIGHT OF WAY RESTRICTS THE USE OF TYPE I ACCESS RAMP AND CITY ENGINEER OR DESIGNEE APPROVAL IS OBTAINED.
2. RAMP SHALL HAVE A 12" WIDE BORDER ON FLAT SURFACE WITH 1/4" GROOVES APPROXIMATELY 3/4" O.C. AS SHOWN IN GROOVING DETAIL.
3. RAMPS SHALL HAVE TRANSVERSE BROOM FINISH TEXTURE ROUGHER THAN THE SURROUNDING SIDEWALK.
4. RAMP GRADES SHALL BE STAKED FOR INSPECTION PRIOR TO PLACEMENT OF CONCRETE.
5. CURB RETURN RADII SHALL BE AS SHOWN ON APPROVED PLANS.
6. CONCRETE THICKNESS SHALL BE 6 INCHES ON NATIVE FROM ECR TO BCR (4" C.A.B. SHALL BE USED AS REQUIRED BY THE CITY ENGINEER).
7. CURB RAMPS SHALL HAVE DETECTABLE WARNING SURFACE THAT EXTENDS THE FULL WIDTH AND 3' DEPTH OF THE RAMP. DETECTABLE WARNING SURFACES SHALL BE 36"x60", DARK GREY COLOR, CAST-IN-PLACE TILES MANUFACTURED BY ARMOR TILE TACTILE SYSTEMS OR APPROVAL EQUAL SUPPLIERS INCLUDE WHITE CAP CONSTRUCTION SUPPLY IN SAN JUAN CAPISTRANO, SANTA ANA, SAN DIEGO, AND RIVERSIDE.
 - * FOR ADA COMPLIANT CURB RAMPS, SURFACE-APPLIED ARMOR TILES MAY BE USED IN-LIEU OF THE CAST-IN-PLACE TILES TO RETROFIT THE RAMP WITH DETECTABLE WARNING SURFACE. APPROVAL FROM THE CITY ENGINEER OR DESIGNEE IS REQUIRED PRIOR TO THE INSTALLATION OF SURFACE-APPLIED ARMOR TILES.
8. INSTALLATION REQUIREMENTS FOR CAST-IN-PLACE DETECTABLE WARNING TILES SHALL CONFORM TO MANUFACTURE'S SPECIFICATIONS.
9. FOR CORNER ACCESS RAMPS, CONCRETE BETWEEN DETECTABLE WARNING SURFACE AND CURB SHALL BE POURED MONOLITHIC WITH THE CURB & GUTTER.
10. THE EDGE OF THE DETECTABLE WARNING SURFACE NEAREST THE STREET SHALL BE BETWEEN 6" AND 8" FROM CURB FACE.

C:\Land Projects\2005\Standard Dwg\ST-2.dwg 11/8/2006 8:22:03 AM PST

APPROVED BY:

 W.E. CAMERON, CITY ENGINEER 23764 7-16-02
 R.C.E. NO. DATE



City of San Clemente
 Public Works Department - Engineering Division

MARK	REVISIONS	APPR.	DATE
△	ADDED DETECTABLE WARNING SURFACE	WEC	8-31-06
△	ADDED DETECTABLE WARNING SURFACE FOR RETROFIT CURB RAMPS	WEC	11-8-06
△	ADDED "DESIGNEE"	WEC	11-8-06

Type II Access Ramp

STD.NO.
ST-2

ACCESS RAMP
PER CITY
STD. ST-1

DRIVEWAY DETAILS
PER CITY STD. ST-9
OR STD. ST-10

25' MIN.

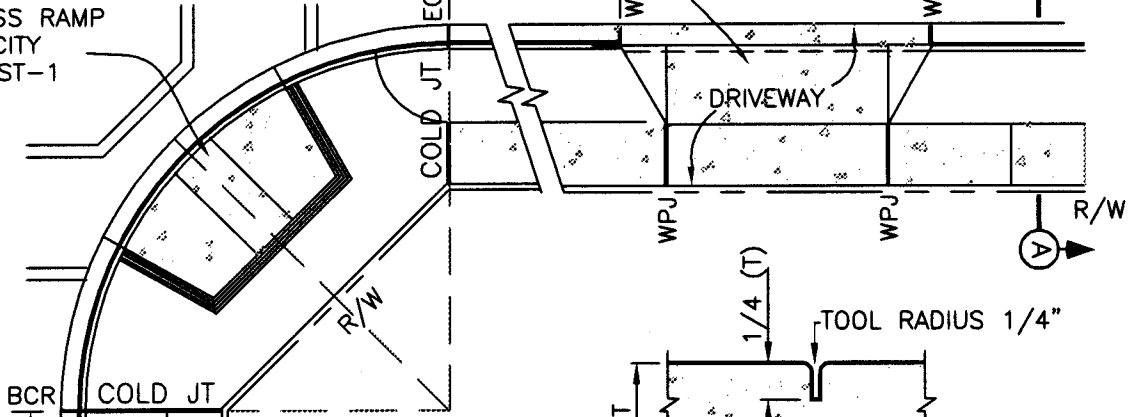

WEAKENED PLANE OR CONTROL JOINT (WPJ)

WPJ AT 10' MAX.
SPACING TYPICAL

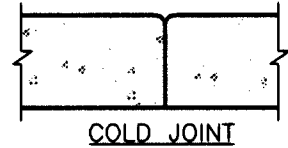

COLD JOINT

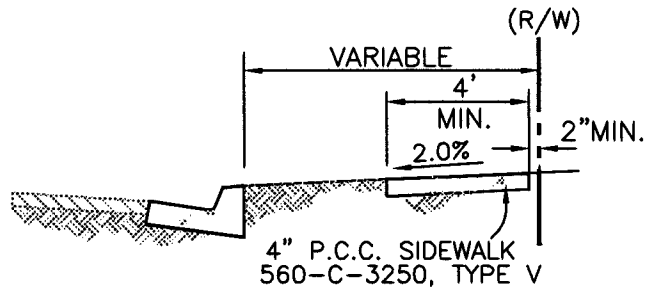

SECTION "A-A"

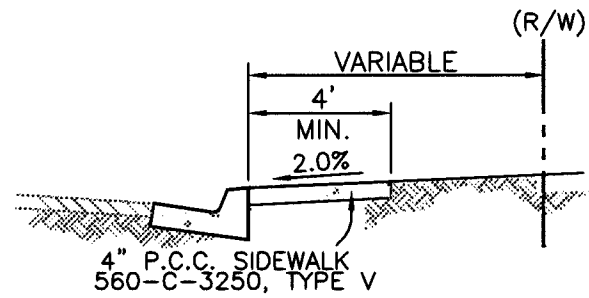

SECTION "B-B"

SIDEWALK
OBSTRUCTION

25' MIN.

14' MIN.

WPJ

(B)

R/W

D:\standards\ST Stds\dwg\ST-3.dwg 10/09/01 03:38:02 PM PDT

APPROVED BY:

W.E. Cameron
W.E. CAMERON, CITY ENGINEER

23764
R.C.E. NO.

7-16-02
DATE



City of San Clemente

Public Works Department - Engineering Division

STD.NO.

Sidewalks

ST-3



SHEET 1 OF 2

MARK	REVISIONS	APPR.	DATE

SIDEWALK CONSTRUCTION NOTES:

1. CONCRETE AND RELATED MATERIALS INCORPORATED INTO CONSTRUCTION SHALL COMPLY IN ALL RESPECTS WITH SECTION 201 OF THE STANDARD SPECIFICATIONS FOR PUBLIC WORKS CONSTRUCTION (GREEN BOOK). ALL CONCRETE SHALL BE CLASS 560-C-3250, TYPE V CEMENT, UNLESS OTHERWISE APPROVED BY THE CITY ENGINEER.
2. CONCRETE REPAIRS SHALL BE MADE BY SAW CUTTING AND REMOVING THE ENTIRE UNIT BETWEEN WEAKENED PLANE JOINTS.
3. SIDEWALK THICKNESS SHALL BE 4" P.C.C. ON NATIVE (4" C.A.B. SHALL BE USED AS REQUIRED BY THE CITY ENGINEER).
4. ALL SUBGRADE SHALL BE CONSTRUCTED TO GRADE AND CROSS SECTION PER CITY STANDARD PLANS FOR APPLICABLE STREET SECTION.
5. SUBGRADE SHALL BE SCARIFIED AND COMPACTED TO A MINIMUM DEPTH OF 12 INCHES. 90% COMPACTION IS REQUIRED BEHIND THE CURB AND IN PARKWAY AREAS. AFTER COMPACTION, THE SUBGRADE SHALL BE FREE OF UNSUITABLE MATERIALS.
6. COLOR ADDITIVES OR PATTERN STAMPED CONCRETE SHALL NOT BE USED, EXCEPT WITHIN EXISTING AREAS WITH DECORATIVE SIDEWALK AS APPROVED BY THE CITY ENGINEER.
7. SIDEWALK AND CURB JOINTS SHALL BE ALIGNED, AT MAXIMUM 10 FEET INTERVALS.
8. WEAKENED PLANE JOINTS SHALL BE 1/4 OF THE DEPTH OF THE CONCRETE THICKNESS BUT NOT LESS THAN 1 INCH. CURBS AND GUTTERS SHALL HAVE WEAKENED PLANE JOINTS OF 2 INCH MINIMUM DEPTH.
9. NO WPJ OR MONOLITHIC CONCRETE PLACEMENT SHALL BE ALLOWED BETWEEN DRIVEWAYS AND SIDEWALK, SIDEWALK AND DRIVEWAY APPROACH, DRIVEWAY APPROACH AND CURB, OR CURB AND SIDEWALK.
10. TRANSIT MIXED CONCRETE DELIVERY TICKETS SHALL BE PROVIDED TO THE INSPECTOR PRIOR TO PLACING CONCRETE TO INSURE THAT THE CONCRETE MEETS SPECIFICATIONS.
11. ALL SURFACES SHALL BE TRUE AND STRAIGHT AND OF UNIFORM WIDTH, FREE OF HUMPS, SAGS, IRREGULARITIES AND IMPERFECTIONS. UNIFORM SURFACES SHALL NOT VARY MORE THAN 0.01 FOOT WHEN MEASURED WITH A 10 FOOT STRAIGHT EDGE.
12. ALL SURFACES SHALL RECEIVE A FINE BROOM FINISH.
13. UPON COMPLETION OF FINISHING OPERATIONS ALL SURFACES SHALL BE SPRAYED WITH CURING COMPOUND.

D:\standards\ST Stds\dwg\ST-3.dwg 10/09/01 03:38:02 PM PDT

APPROVED BY:  W.E. CAMERON, CITY ENGINEER					City of San Clemente Public Works Department - Engineering Division	
	23764	7-16-02		<div style="display: flex; justify-content: space-between;"> <div style="width: 40%;"> <p style="font-size: 2em; margin: 0;">Sidewalks</p> </div> <div style="width: 30%; text-align: center;"> <p style="font-size: 1.5em; margin: 0;">STD.NO.</p> <p style="font-size: 2em; margin: 0;">ST-3</p> </div> </div>		
	R.C.E. NO.	DATE				
MARK	REVISIONS	APPR.	DATE	SHEET 2 OF 2		

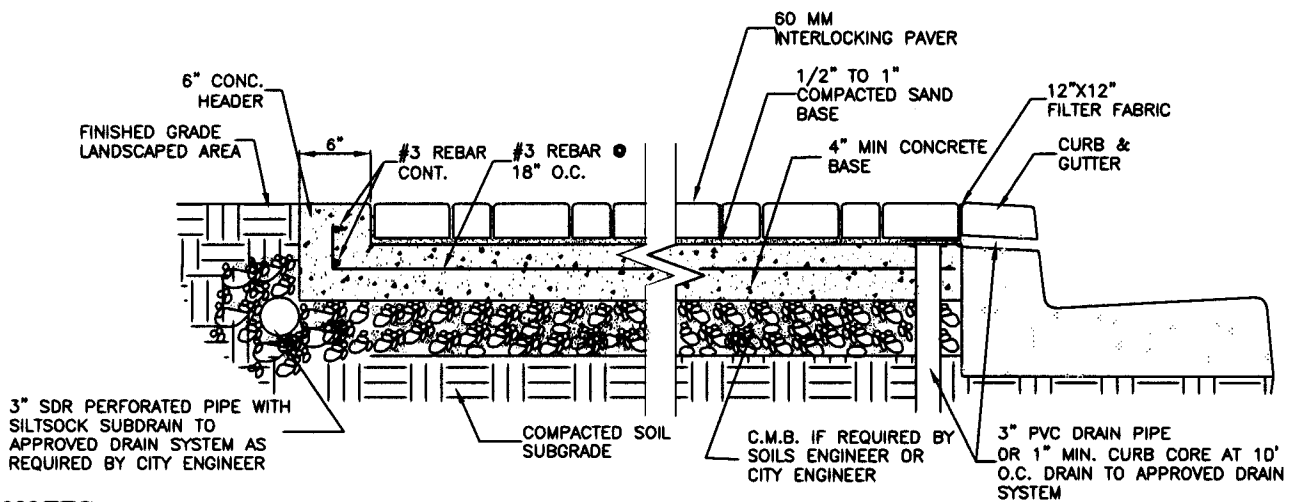
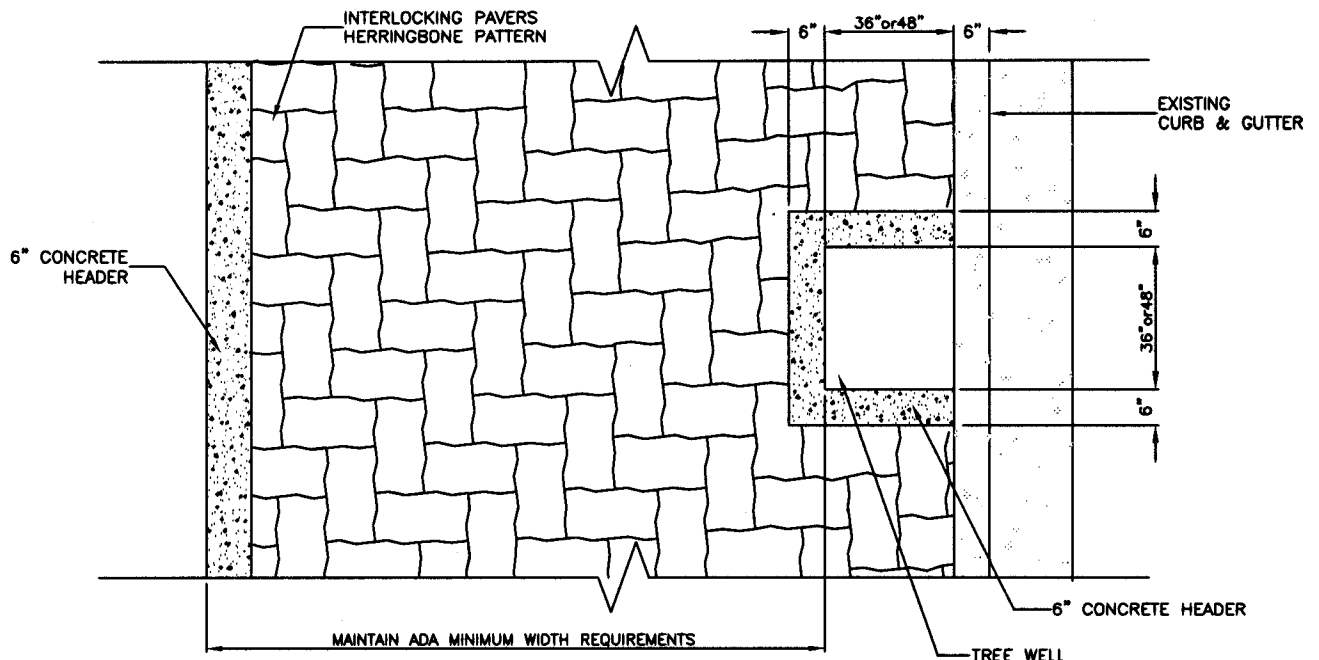

NOTES:

1. ALL CONCRETE SHALL BE P.C.C. CLASS 560-C-3250, TYPE V CEMENT.
2. CONCRETE BASE SLOPE MIN. 1%, MAX. 2%, WITH WEAKENED PLANE JOINTS AT 10' O.C. #3 REBAR SHALL BE PLACED AT 18" O.C. WITH BARS CENTERED IN CONCRETE HEADER. MAINTAIN A.D.A. MINIMUM SIDEWALK WIDTH REQUIREMENTS.
3. CONCRETE HEADER SURFACES SHALL HAVE A MEDIUM BROOM FINISH, NATURAL GRAY. PROVIDE SMOOTH JOIN WITH EXISTING CONCRETE NOSE ALL EDGES. CONCRETE AREA SHALL BE DRAIN TESTED PRIOR TO INSTALLATION OF SAND BASE.
4. PAVERS SHALL BE MANUFACTURED TO COMPLY WITH ASTM C936-96 & TESTED ACCORDING TO ASTM C140. AVERAGE COMPRESSIVE STRENGTH WILL BE MIN. 8,000 PSI, WITH NO INDIVIDUAL UNIT LESS THAN 7,200 PSI.
5. PAVER PATTERN & COLOR SHALL BE OLSEN PAVINGSTONE, HERRINGBONE PATTERN, "B-2" RED/BROWN/CHARCOAL "SUNBURST", UNIVERSAL BLOCK.
6. DRIVEWAY APPROACHES AND CORNER ACCESS RAMPS SHALL HAVE A MINIMUM DEPTH OF 8" CONCRETE WITH #4 REBAR, 18" O.C. WITH 80 MM PAVERS. RAMPS SHALL HAVE 12" WIDE GROOVED P.C.C. BORDER PER CITY RAMP STANDARDS.
7. DRAINAGE PLANS SHALL BE INCLUDED WITH IMPROVEMENT PLAN SUBMITTAL.
8. TREE WELLS SHALL BE 36"x36" OR 48"x48" WITH MINIMUM 36" DEEP ROOT GUARD AS APPROVED BY CITY ENGINEER. EXISTING TREES MAY REQUIRE ALTERNATIVE DESIGN AND TREE GRATES. NEW STREET TREES REQUIRE TREE GRATE.

D:\standards\ST-Stds.dwg\ST-4.dwg 10/09/01 04:52:25 PM PBT

APPROVED BY:

W.E. Cameron
W.E. CAMERON, CITY ENGINEER

23764 7-16-02
R.C.E. NO. DATE



City of San Clemente
Public Works Department - Engineering Division

MARK	REVISIONS	APPR.	DATE

**Interlocking Paver
Sidewalk**

STD.NO.
ST-4
SHEET 1 OF 4

INTERLOCKING CONCRETE PAVERS

PART 1 GENERAL

1.01 SECTION INCLUDES

- A. Concrete paver and edge units.
- B. Bedding and joint sand.
- C. Edge restraints

1.02 RELATED SECTIONS

All materials incorporated into construction shall comply in all respects of the Standard Specifications for Public Works Construction "Greenbook", latest edition.

- A. Section: 200-Rock Materials
- B. Section: 201-Concrete, Mortar, and Related Materials

1.03 REFERENCES

A. American Society of Testing and Materials (ASTM):

- 1. C 33 Specification for Concrete Aggregates.
- 2. C 136, Method for Sieve Analysis for Fine and Coarse Aggregate.
- 3. C 140, Sampling and Testing Concrete Masonry Units.
- 4. C 144, Standard Specification for Aggregate for Masonry Mortar.
- 5. C 936, Specification for Solid Interlocking Concrete Paving Units.
- 6. C 979, Specification for Pigments for Integrally Colored Concrete.
- 7. D 698, Test Methods for Moisture Density Relations of Soil and Soil Aggregate Mixtures Using a 5.5-lb Rammer and 12 in. drop.
- 8. D 1557, Test Methods for Moisture Density Relations of Soil and Soil Aggregate Mixtures Using a 10-lb Rammer and 18 in. drop.

B. Interlocking Concrete Pavement Institute (ICPI)

- 1. Tech Spec No. 1, Glossary of Terms
- 2. Tech Spec No. 2, Construction of Interlocking Concrete Pavements.
- 3. Tech Spec No. 3, Edge Restraints for Interlocking Concrete Pavements.

1.04 QUALITY ASSURANCE

- A. Installation shall be by a contractor and crew with at least one year of experience in placing interlocking concrete pavers on projects of similar nature or dollar cost.
- B. Contractor shall hold current Basic Level Certificate from the Interlocking Concrete Pavement Institute contractor certification program.
- C. Contractor shall conform to all local and state licensing and bonding requirements.

1.05 SUBMITTALS

- A. Shop or product drawings, and product data.
- B. Full size samples of concrete paving units to indicate color and shape selections.
- C. Sieve analysis for grading of bedding and joint sand.
- D. Test results from and independent testing laboratory for compliance of paving unit requirements to ASTM C 936.

1.06 MOCK-UPS

- A. Install a 4 ft x 4 ft paver area as described in Article 3.02
- B. This area will be used to determine surcharge of the bedding sand layer, joint sizes, lines, laying pattern(s), color(s), and texture of the job.

D:\standards\ST Studs\dwg\ST-4.dwg 10/09/01 04:25:25 PM PDT

APPROVED BY:

W.E. Cameron
W.E. CAMERON, CITY ENGINEER

23764 7-16-02
R.C.E. NO. DATE



City of San Clemente

Public Works Department - Engineering Division

MARK	REVISIONS	APPR.	DATE

**Interlocking Paver
Sidewalk**

STD.NO.
ST-4
SHEET 2 OF 4

C. This area shall be the standard from which the work will be judged and shall not be incorporated into the work.

1.07 DELIVERY, STORAGE, AND HANDLING

- A. Deliver concrete pavers to the site in plastic wrapped cubes capable of transfer by forklift. Unload pavers at job site in such a manner that no damage occurs to the product.
- B. Cover sand with waterproof covering to prevent exposure to rainfall or removal by wind. Secure the covering in place.
- C. Coordinate delivery and paving schedule to minimize interference with normal use of buildings adjacent to paving.

PART 2 PRODUCTS

2.01 CONCRETE PAVERS

A. Supplied by a member of the Interlocking Concrete Pavement Institute (ICPI). The ICPI supplier is:

Olsen Pavingstone, Inc.
 P.O. Box 1330
 San Juan Capistrano, CA 92693
 (949) 728-0415 fax-0540

B. Interlocking Concrete Paving Stones shall be Universal shape with dimensions of 8.75" long x 4.375" wide. Thickness will be 60 mm for pedestrian paving and 80 mm for vehicular paving. Thickness will be 80 mm for driveway approaches and corner ADA compliant ramps. Manufactured edge units will be available. Colors will be a Sunburst blend of Red, Brown and Charcoal.

C. Meet the following requirements set forth in ASTM C 936, Standard Specification for Interlocking Concrete Paving Units.

- 1. Average compressive strength of 8,000 psi with no individual unit under 7,200 psi.
- 2. Average absorption of 5% with no unit greater than 7% when tested in accordance with ASTM C 140.

2.02 BEDDING AND JOINT SAND

- A. Clean, non-plastic, free from deleterious or foreign matter, manufactured from crushed rock. Do not use limestone screenings or stone dust that do not conform to the grading requirements in Table 1.
- B. Sieve according to ASTM C 136
- C. The bedding sand shall conform to the grading requirements of ASTM C33. The joint sand shall conform to the grading requirements of ASTM C33 or C144.

2.03 EDGE RESTRAINTS

A. Edge restraints shall be existing concrete curbs and sidewalks, or new concrete.

PART 3 EXECUTION

3.01 EXAMINATION

A. Verify that concrete base conforms to the surface tolerances and elevations, and to the specifications.

D:\standards\ST Stds\dwg\ST-4.dwg 10/09/01 04:25:25 PM PBT

APPROVED BY:

W.E. Cameron
 W.E. CAMERON, CITY ENGINEER

23764 7-16-02
 R.C.E. NO. DATE



City of San Clemente
 Public Works Department - Engineering Division

MARK	REVISIONS	APPR.	DATE

**Interlocking Paver
 Sidewalk**

STD.NO.
ST-4
 SHEET 3 OF 4

- B. Verify location, type, installation and elevations of edge restraints around the perimeter area to be paved.
- C. Verify that the concrete base is cured and ready to support sand, pavers, and imposed loads.
- D. Beginning of bedding sand and paver installation means acceptance of base and edge restraints.

3.02 INSTALLATION



(Note: Concrete base course, edge & ramp strips and drainage to be constructed prior to installation of pavers in accordance with City of San Clemente Standard for Interlocking Paver Sidewalk.)

- A. Spread the bedding sand evenly over the concrete base course following drainage testing by flood method and screed to a nominal 1 in. thickness, not exceeding 1.5 in. thickness nor less than 0.5 in. thickness. The screeded sand should not be disturbed. Place sufficient sand to stay ahead of the laid pavers. Do not use the bedding sand to fill depressions in the base surface.
- B. Ensure that pavers are free of foreign material before installation.
- C. Lay the pavers in the pattern(s) as shown on the drawings. Maintain straight pattern lines. Standard installation pattern shall be Herringbone.
- D. Joints between the pavers on average shall be between 1/16 in. and 3/16 in. wide.
- E. Fill gaps at the edges of the paved area with edge units or cut pavers.
- F. Cut pavers to be placed along the edge with a masonry saw.
- G. Use a low amplitude, high frequency plate vibrator capable of at least 5,000 foot pound compaction at a frequency of 75 hz - 100 hz.
- H. Vibrate the pavers, sweeping dry joint sand into the joints and vibrating until they are full. This will require at least two or three passes with the vibrator. Do not vibrate within 3 ft of the unrestrained edges of the paving units.
- I. All work to within 3 ft of the laying face must be left fully compacted with sand-filled joints at the end of each day. Cover the laying face with plastic sheets overnight if not closed with cut and compacted pavers.
- J. Sweep off excess sand when the job is complete.
- K. The final surface elevations shall not deviate more than 3/8 in. under a 10 ft long straightedge.
- L. The surface elevation of pavers shall be 1/8 to 1/4 in. above adjacent drainage inlets, concrete collars or channels.

3.03 FIELD QUALITY CONTROL

- A. Do not install sand or pavers during heavy rain.
- B. After removal of excess sand, check final elevations for conformance to the drawings.
- C. A pre-construction meeting is required with a City Engineering Inspector prior to commencement of any work. Required inspections are (at a minimum):
 1. Subgrade & Subdrains
 2. Forms for concrete base, tree wells, borders and ramps
 3. Steel placement
 4. Concrete placement
 5. Flood testing and drainage review
 6. Placement of filter fabric
 7. Placement of bedding material
 8. Placement of pavers
 9. Installation of joint sand
 10. Final inspection.

D:\standards\ST-4.dwg 10/09/01 04:25:25 PM PBT

APPROVED BY:  W.E. CAMERON, CITY ENGINEER		23764 R.C.E. NO.	7-16-02 DATE	 City of San Clemente Public Works Department - Engineering Division																									
<table border="1" style="width: 100%; border-collapse: collapse;"> <thead> <tr> <th style="width: 10%;">MARK</th> <th style="width: 60%;">REVISIONS</th> <th style="width: 15%;">APPR.</th> <th style="width: 15%;">DATE</th> </tr> </thead> <tbody> <tr><td> </td><td> </td><td> </td><td> </td></tr> <tr><td> </td><td> </td><td> </td><td> </td></tr> <tr><td> </td><td> </td><td> </td><td> </td></tr> <tr><td> </td><td> </td><td> </td><td> </td></tr> </tbody> </table>				MARK	REVISIONS	APPR.	DATE																	<table border="1" style="width: 100%; border-collapse: collapse;"> <tr> <td style="padding: 10px; text-align: center;"> Interlocking Paver Sidewalk </td> <td style="padding: 10px; text-align: center;"> STD.NO. ST-4 </td> </tr> <tr> <td colspan="2" style="padding: 5px; text-align: center;"> SHEET 4 OF 4 </td> </tr> </table>		Interlocking Paver Sidewalk	STD.NO. ST-4	SHEET 4 OF 4	
MARK	REVISIONS	APPR.	DATE																										
Interlocking Paver Sidewalk	STD.NO. ST-4																												
SHEET 4 OF 4																													

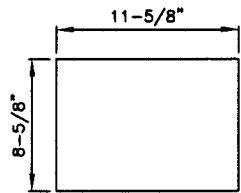

DESCRIPTION: TERRA QUARRY TILES OR APPROVED EQUAL
 SIZE: 8-5/8" X 11-5/8"
 THICKNESS: 1/2"
 COLOR: "MISSION RED"
 GROUT JOINT: 3/8"
 SURFACE: UNGLAZED, NATURAL CLAY, NON-SKID AND SLIP-RESISTANT PER ADA STD.
 BACK: V-NOTCHED
 COMPRESSIVE STRENGTH: 8,000 P.S.I. MIN.

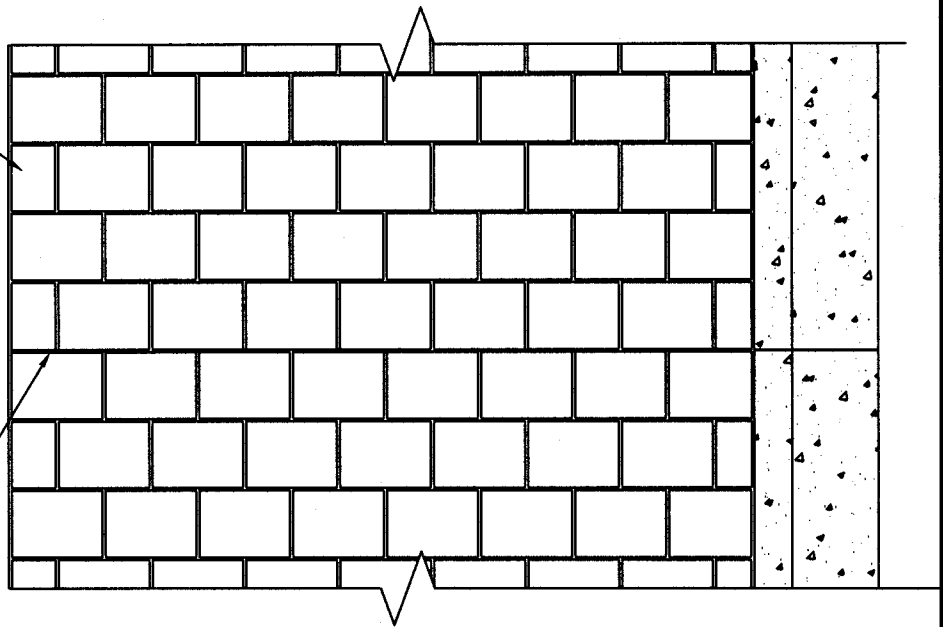

WEAKENED PLANE JOINT AT 10' O.C. (TYPICAL)

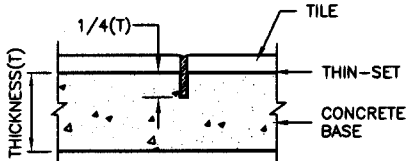

WEAKENED PLANE JOINT (WPJ) N.T.S.

FINISHED GRADE LANDSCAPED AREA

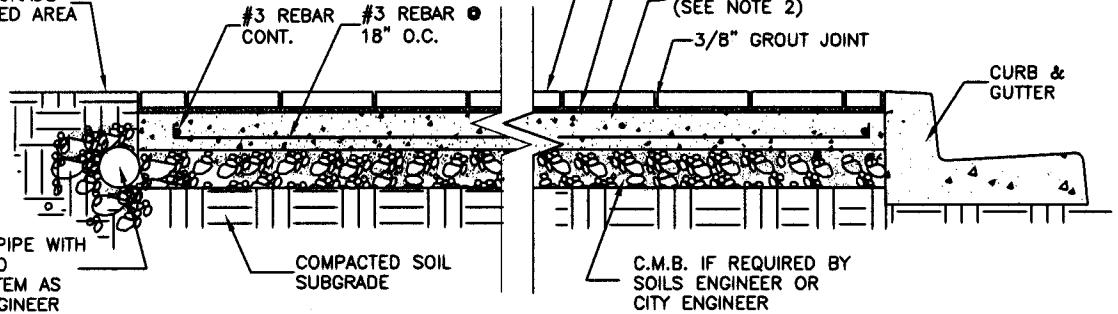

3" SDR PERFORATED PIPE WITH SILT SOCK SUBDRAIN TO APPROVED DRAIN SYSTEM AS REQUIRED BY CITY ENGINEER

COMPACTED SOIL SUBGRADE

C.M.B. IF REQUIRED BY SOILS ENGINEER OR CITY ENGINEER

NOTES:

1. ALL CONCRETE SHALL BE P.C.C. CLASS 560-C-3250, TYPE V CEMENT.
2. CONCRETE BASE THICKNESS SHALL BE 4" MINIMUM, 6" THICK WITHIN DRIVEWAY AREA WITH SLOPE OF 1% MINIMUM TO 2% MAXIMUM. MAINTAIN A.D.A. MINIMUM SIDEWALK WIDTH REQUIREMENTS.
3. WEAKENED PLANE JOINTS SHALL BE CONSTRUCTED IN CONCRETE BASE AT 10' INTERVALS WITH #3 REBAR AT 18" O.C.
4. DRIVEWAY APPROACHES AND CORNER ACCESS RAMPS SHALL HAVE A MINIMUM DEPTH OF 6" CONCRETE WITH #4 REBAR, 18" O.C. RAMPS SHALL HAVE 12" WIDE GROOVED P.C.C. BORDER PER CITY RAMP STANDARDS.
5. DRAINAGE PLANS SHALL BE INCLUDED WITH IMPROVEMENT PLAN SUBMITTAL.
6. TREE WELLS SHALL BE 36"x36" OR 48"x48" WITH MINIMUM 36" DEEP ROOT GUARD AS APPROVED BY CITY ENGINEER. EXISTING TREES MAY REQUIRE ALTERNATIVE DESIGN AND TREE GRATES. NEW STREET TREES REQUIRE TREE GRATE.
7. TILE PATTERN & COLOR SHALL BE TERRAZZO, 8-5/8"x11-5/8" CLAY TILE, "MISSION RED" COLOR OR APPROVED EQUAL. SUPPLIERS INCLUDE DAL TILE
8. TILE INSTALLATION REQUIREMENTS PER MANUFACTURER'S RECOMMENDATIONS.
9. ANY EXCEPTIONS TO THIS STANDARD REQUIRE CITY ENGINEER APPROVAL.

D:\standard dwg\technical std dwg\ST-5.dwg 04/07/2003 01:49:11 PM PDI

APPROVED BY:

W.E. Cameron

W.E. CAMERON, CITY ENGINEER

23764

R.C.E. NO.

4-7-03

DATE



City of San Clemente

Public Works Department - Engineering Division

STD.NO.

Tile Sidewalk

ST-5

MARK	REVISIONS	APPR.	DATE

SHEET 1 OF 1

\\cd\graphics_cd\autocad engr drawings\standards\standard provisions & deqs\standard dwg\technical std dwg\st-5 at.dwg 5/28/2013

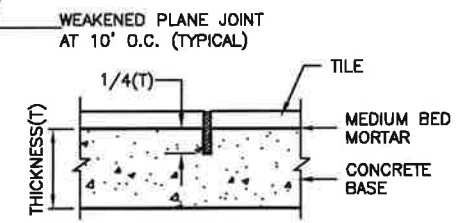
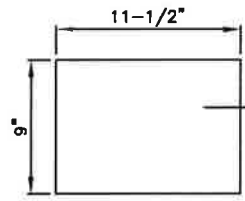
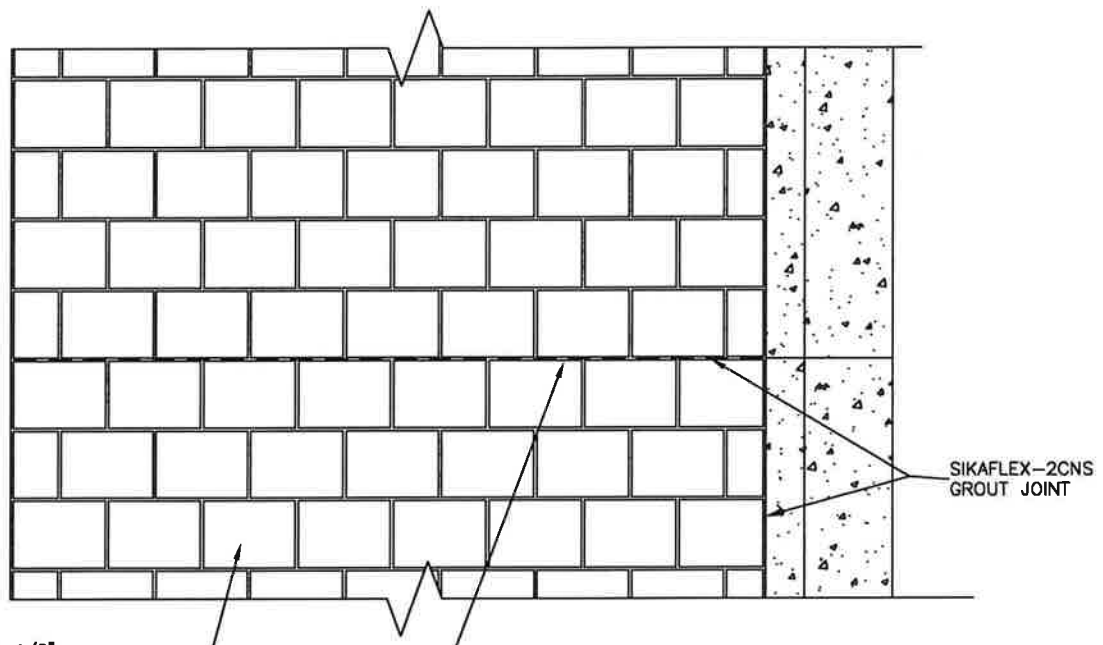

DESCRIPTION: "OLE HANSON REPLICA TILE"
 SIZE: 9" X 11-1/2"
 THICKNESS: 1-1/4"
 COLOR: "VARIABLE RED"
 SURFACE: UNGLAZED, CONCRETE, NON-SKID
 AND SLIP-RESISTANT PER ADA STANDARD.
 BACK: ROUGHENED
 COMPRESSIVE STRENGTH: 4,000 P.S.I. MIN.

WEAKENED PLANE JOINT (WPJ)
N.T.S.

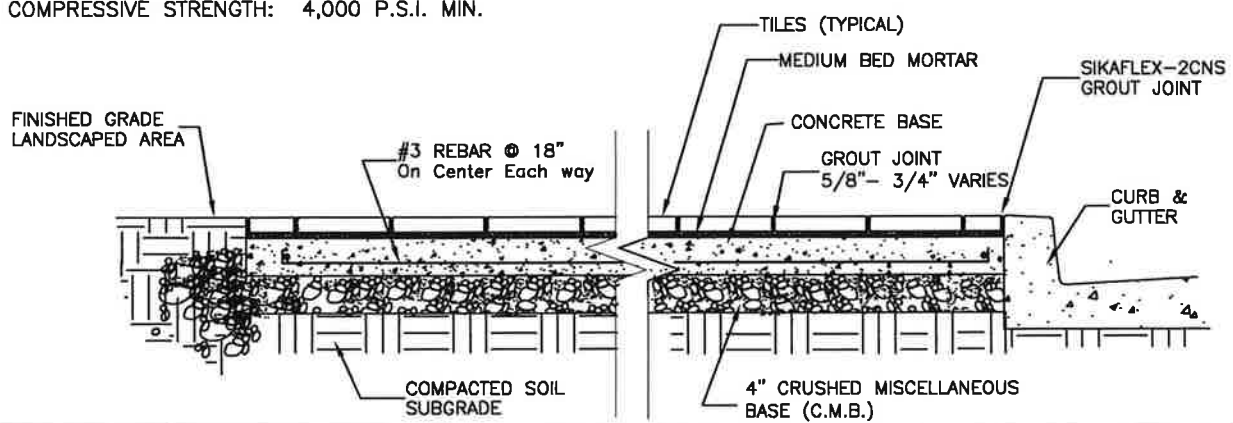

APPROVED BY: *W.E. Cameron*
 W.E. CAMERON, CITY ENGINEER 23764 5-29-13
 R.C.E. NO. DATE



City of San Clemente
 Public Works Department - Engineering Division

MARK	REVISIONS	APPR.	DATE

"Ole Hanson"
Replica Tile Sidewalk
 (Arto Brick Tile)

STD.NO.
ST-5A
 SHEET 1 OF 2

NOTES:

UNLESS DIRECTED OR APPROVED OTHERWISE BY THE CITY ENGINEER,

1. SIDEWALK CROSS SLOPE SHALL BE 1% MINIMUM TO 2% MAXIMUM SLOPED TO DRAIN TO THE CURB.
2. SIDEWALK TO MEET MINIMUM STATE AND FEDERAL (ADA) WIDTH REQUIREMENTS.
3. CONCRETE BASE SHALL BE P.C.C. CLASS 560-C-3250, TYPE-V CEMENT. CONCRETE BASE THICKNESS SHALL BE 4" MINIMUM WITH #3 REBAR AT 18" ON CENTER EACH WAY. CONCRETE BASE FOR DRIVEWAY APPROACHES AND CORNER ACCESS RAMPS SHALL HAVE A MINIMUM THICKNESS OF 6" WITH #4 REBAR AT 18" ON CENTER EACH WAY. CURB RAMPS SHALL HAVE 12" WIDE GROOVED P.C.C. BORDER PER CITY CURB RAMP STANDARDS. CONCRETE BASE SHALL BE PLACED OVER 4" MINIMUM THICKNESS OF CRUSHED MISCELLANEOUS BASE OVER NATIVE MATERIAL WITH 90% RELATIVE COMPACTION. CONCRETE TO BE CURED WITH WATER ONLY.
4. TILE SHALL BE "OLE HANSEN REPLICA TILE", WITH A "VARIABLE RED " COLOR AND MEASURING 9" WIDE X 11-1/2" LONG X 1-1/4" THICK, WITH A ROUGHENED BACK AND MINIMUM COMPRESSIVE STRENGTH OF 4,000 PSI. MANUFACTURED BY ARTO BRICK, GARDENA, CA. TILE SHALL BE INSTALLED PER MANUFACTURE'S RECOMMENDATIONS. CONCRETE BASE TO CURE WITH A MINIMUM OF 28 DAYS BEFORE INSTALLING TILE.
5. THE TILE SURFACE SHALL BE UNGLAZED CONCRETE, NON-SKID, SLIP RESISTANT AND COMPLY WITH THE AMERICANS WITH DISABILITIES ACT REQUIREMENTS. IN ACCORDANCE WITH SECTION 28CFR PART 36, THE TILE FOR SIDEWALK AREAS WITH SLOPES LESS THAN 5% SHALL HAVE A STATIC COEFFICIENT OF FRICTION OF 0.6 OR GREATER. TILE SIDEWALK/RAMP AREAS WITH SLOPES GREATER THAN 5% SHALL HAVE A STATIC COEFFICIENT OF FRICTION OF 0.8 OR GREATER.
6. THE LONG SIDE OF THE TILE SHALL BE PERPENDICULAR TO THE BACK OF CURB WITH THE JOINTS OF THE NEXT ROW STAGGERED ONE HALF TILE AS SHOWN HEREON.
7. WHEN INSTALLED ALONG A CURVED SECTION OF STREET, THE TILE SHALL BE LAID RADIAL (FANNED) AROUND THE CURVE WITH THE TILES CUT (TAPERED) TO MAINTAIN THE STAGGERED PATTERN AND UNIFORM JOINT WIDTH.
8. AT CURB RETURNS THE STAGGERED PATTERN IS TO BE MAINTAINED IN A PERPENDICULAR ALIGNMENT (NON RADIAL) UNTIL IT TERMINATES AT THE BACK OF CURB, CURB RAMP HEADER OR BACK OF SIDEWALK.
9. TILE WITHIN THE CURB RAMP SHALL BE INSTALLED WITH THE LONG SIDE PERPENDICULAR TO THE BACK OF THE TRUNCATED DOMES WITH THE JOINTS OF THE NEXT ROW STAGGERED ONE HALF TILE. THE STAGGERED PATTERN IS TO BE MAINTAINED IN A PERPENDICULAR ALIGNMENT UNTIL THE PATTERN TERMINATES INTO THE BACK OF CURB, CURB RAMP HEADER OR BACK OF SIDEWALK.
10. TILES ARE TO BE SET WITH A TYPE "S" "MEDIUM BED MORTAR" THAT MEETS ASTM C270 AND HAS A MINIMUM COMPRESSION STRENGTH OF 1,800 PSI.
11. THE GROUT JOINTS SHALL BE 5/8" TO 3/4" IN WIDTH AND FLUSH WITH THE TOP OF THE TILE IN COMPLIANCE WITH THE AMERICANS WITH DISABILITIES ACT (ADA). GROUT SHALL BE TYPE "S" "MORTAR" AND MEET ASTM C270, WITH A MINIMUM COMPRESSION STRENGTH OF 1,800 PSI.
12. NOT TO BE USED IN STREETS, COMMERCIAL DRIVEWAYS OR WHERE SUBJECT TO HEAVY TRUCK TRAFFIC.
13. USE OF TILE ADJACENT TO COMMERCIAL DRIVEWAYS OR RESTAURANT USES MAY BE REQUIRED TO ADD ADDITIVES TO THE GROUT MIX TO INCREASE STRENGTH OR PROTECT AGAINST STAINING.
14. WEAKENED PLANE JOINTS SHALL BE SAWED CROSSWAYS TO THE PATH OF TRAVEL, SPACED NO MORE THAN 10 FEET APART ON AN EVEN MULTIPLE OF FULL TILE WIDTHS AND FILLED FLUSH WITH SIKAFLEX - 2C NS (OR APPROVED EQUAL) IN ACCORDANCE WITH THE MANUFACTURE'S RECOMMENDATIONS. SIKAFLEX-2CNS SHALL ALSO BE USED IN GROUT JOINT BETWEEN TILE AND BACK OF CURB.

\\cd\graphics_cad\autocad engr drawings\standards\standard provisions & dwgs\standard dwg\technical std dwg\st-5 alt.dwg 5/26/2013

APPROVED BY: W.E. Cameron 23764 5-24-13
 W.E. CAMERON, CITY ENGINEER R.C.E. NO. DATE



City of San Clemente
 Public Works Department - Engineering Division

MARK	REVISIONS	APPR.	DATE

**"Ole Hanson"
 Replica Tile Sidewalk
 (Arto Brick Tile)**

STD.NO.
ST-5A
 SHEET 2 OF 2

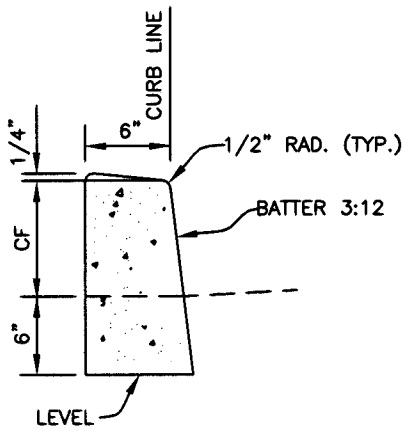

**A1-6
AND
A1-8**

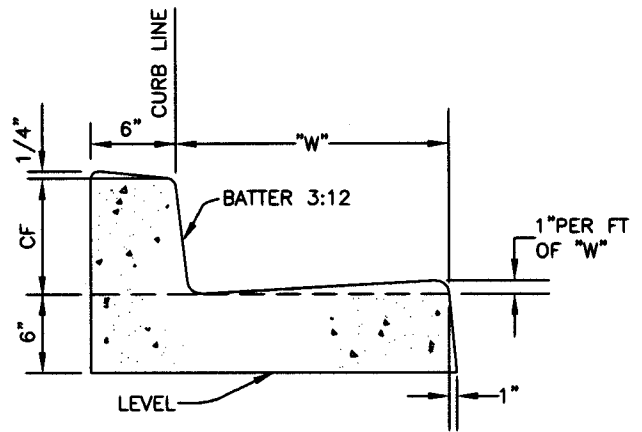

**A2-6
AND
A2-8**

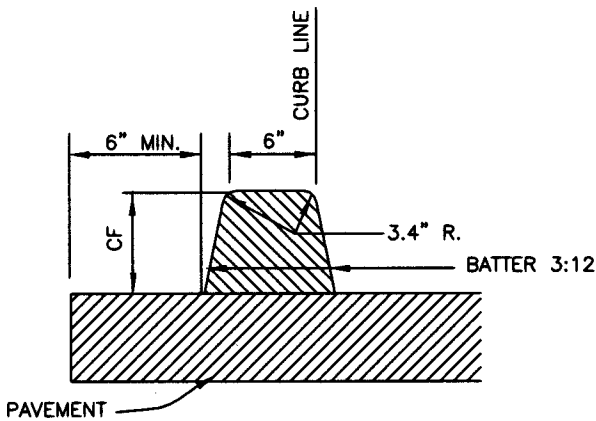

**D1-6
AND
D1-8**

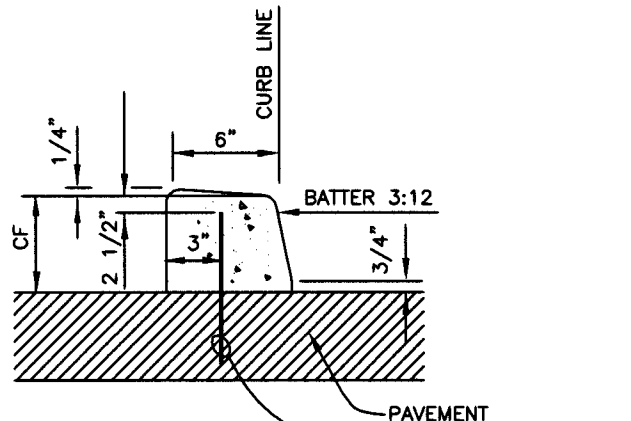

**C1-6
AND
C1-8**

#4 DOWEL AT 4' O.C.
10" MIN. LENGTH,
GROUTED IN PLACE.

NOTES:

1. ALL DIMENSIONS ARE MEASURED IN INCHES.
2. CURB FACE HEIGHT IS THE LAST NUMBER IN THE DESIGNATION, "A2-6".
3. TYPES A1, A2, AND C1 ARE CONSTRUCTED OF PORTLAND CEMENT CONCRETE, CLASS 560-C-3250, TYPE V.
4. TYPE D1 IS CONSTRUCTED OF ASPHALT CONCRETE.
5. TYPE C1 CURB SHALL BE ANCHORED WITH DOWELS AS SHOWN OR WITH AN EPOXY MUST BE APPROVED BY THE CITY ENGINEER.
6. GRADE SHALL BE MEASURED AT TOP OF CURB.
7. RELATIVE COMPACTION REQUIREMENT FOR TOP 12" OF SUBGRADE IS 90%. WHEN CLASS II BASE IS USED UNDER STREET PAVEMENT, CLASS II BASE SHALL ALSO BE PLACED UNDER CURB AND GUTTER.
8. WEAKENED PLANE JOINTS SHALL BE PLACED PER CITY STANDARD PLAN, ST-3.
9. ALL SURFACES SHALL RECEIVE A MEDIUM BROOM FINISH AND APPLY CURING COMPOUND.
10. "W" IS 24" UNLESS OTHERWISE SPECIFIED.

D:\standards\st standards\st-6.dwg 06/24/2002 08:50:15 AM PDT

APPROVED BY:

 W.E. CAMERON, CITY ENGINEER 23764 7-16-02
 R.C.E. NO. DATE



City of San Clemente
 Public Works Department - Engineering Division

MARK	REVISIONS	APPR.	DATE

<p>Curbs And Gutters</p>	<p>STD.NO. ST-6</p>
---------------------------------	--------------------------------

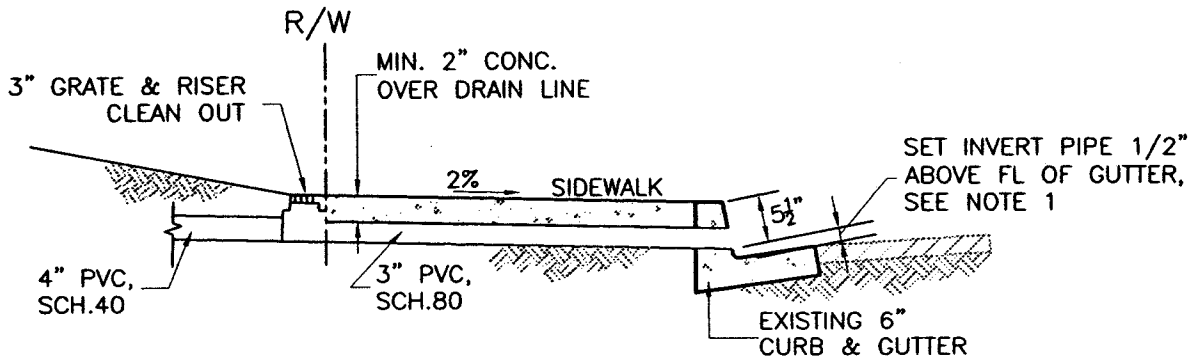
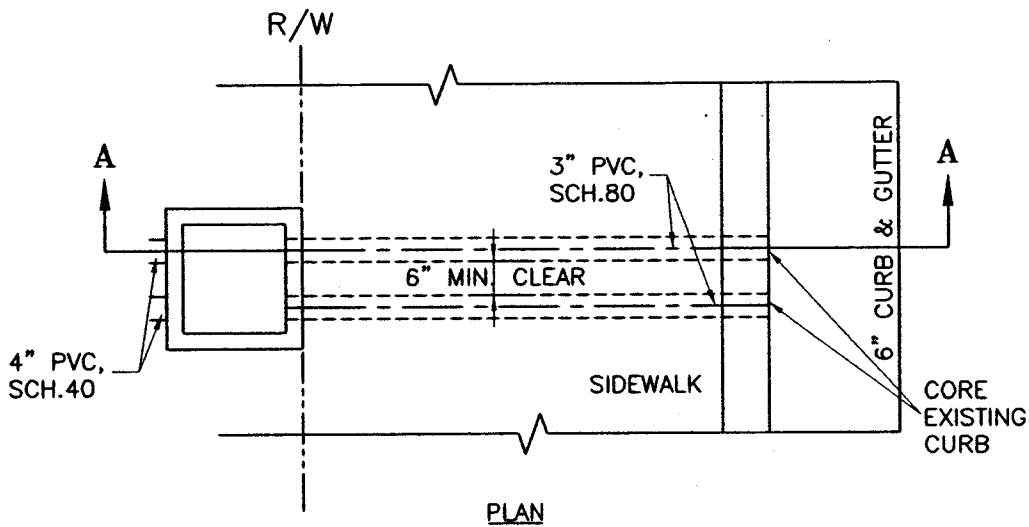

SECTION A-A

NOTES:

1. IF CORE FALLS IN A LOCAL DEPRESSION, USE 3" FROM TOP OF CURB TO TOP OF PIPE.
2. AREA DRAIN LINES IN THE CITY RIGHT-OF-WAY SHALL BE SCHEDULE 80 P.V.C.
3. MAXIMUM DRAIN PIPE SIZE TO BE 3" DIAMETER FOR 6" CURB FACE AND 4" DIAMETER FOR 8" CURB FACE.
4. CORE DRILL BENEATH CONCRETE OR REMOVE & REPLACE WHOLE SIDEWALK PANEL FROM JOINT TO JOINT.
5. TYPE, DIMENSIONS AND ELEVATIONS OF P.C.C. CURB & GUTTER PER IMPROVEMENT PLAN.

D:\standards\ST Stds\dwg\ST-7.dwg 06/24/2002 09:21:58 AM PDT

APPROVED BY:

W.E. Cameron
W.E. CAMERON, CITY ENGINEER

23764
R.C.E. NO.

7-1602
DATE



City of San Clemente

Public Works Department - Engineering Division

MARK	REVISIONS	APPR.	DATE

Curb Drain

STD.NO.

ST-7

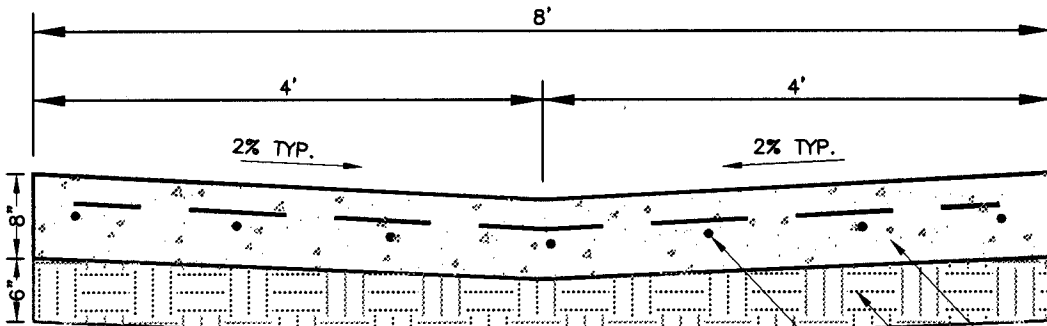
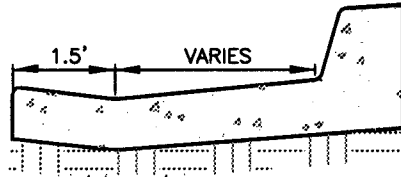
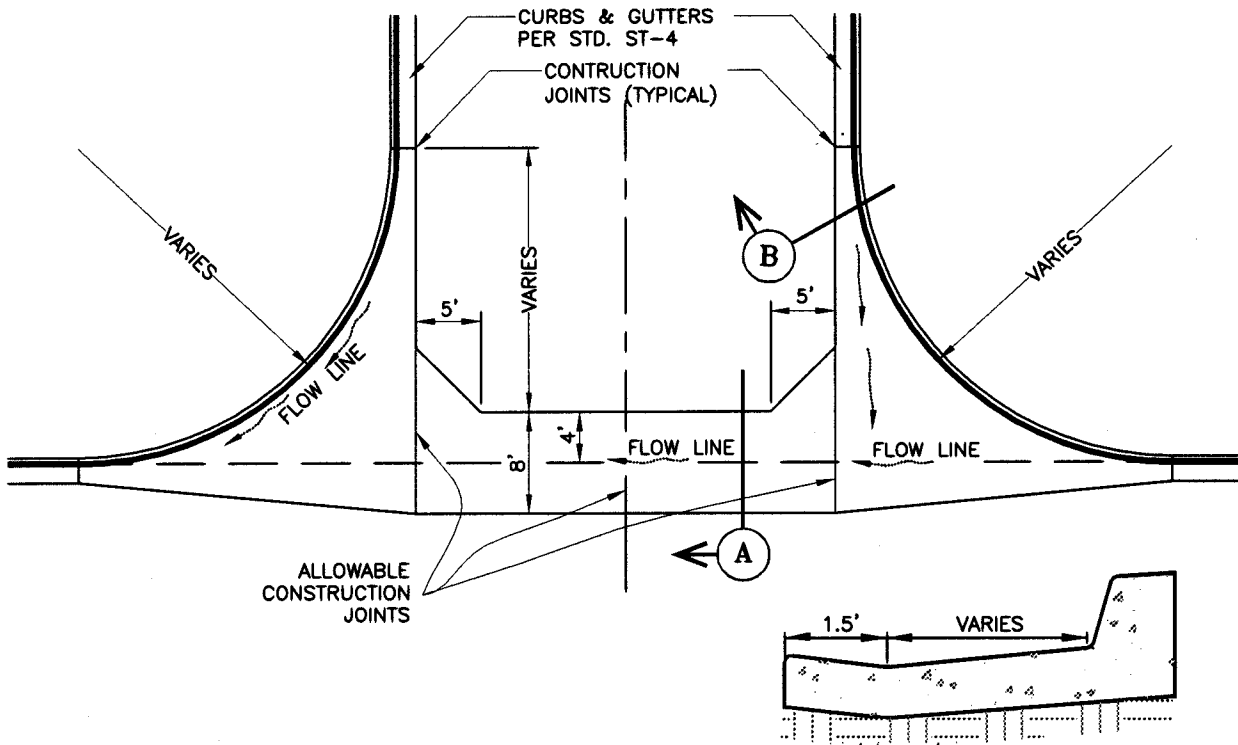

SECTION A-A
NOT TO SCALE

560-C-3250, TYPE V P.C.C.

C.A.B.

#4 BARS @ 12" BOTH WAYS

NOTES:

1. ALL CONCRETE SHALL BE CLASS 560-C-3250, TYPE V CEMENT.
2. CROSS GUTTER AND SPANDRELS THICKNESS SHALL BE 8" P.C.C. OVER 6" C.A.B.
3. ALL SURFACES SHALL RECEIVE A HEAVY BROOM FINISH.
4. IMMEDIATELY AFTER FINISHING OPERATIONS ARE COMPLETE, CURING COMPOUND SHALL BE APPLIED.
5. CONTRACTOR SHALL PROTECT THE CONCRETE WORK FROM ALL TRAFFIC AND CONSTRUCTION EQUIPMENT FOR AT LEAST SEVEN DAYS, UNLESS OTHERWISE APPROVED BY THE CITY ENGINEER.

D:\standards\ST Stds.dwg ST-6.dwg 12/06/2001 07:38:11 AM PST

APPROVED BY:

W.E. Cameron
W.E. CAMERON, CITY ENGINEER

23764
R.C.E. NO.

7-16-02
DATE



City of San Clemente
Public Works Department - Engineering Division

MARK	REVISIONS	APPR.	DATE

**Cross and Longitudinal
Gutters**

STD.NO.

ST-8

DRIVEWAY APPROACH *	MIN. "W"	MAX. "W"
SINGLE CAR GARAGE	12'	16'
2-CAR GARAGE	16'	20'
3-CAR GARAGE	24'	28'
MULTI-FAMILY	28'	32'

* TOTAL DRIVEWAY APPROACH WIDTH MAY NOT EXCEED 70% OF FRONTAGE PROPERTY WIDTH.

VALUES OF "X"		
SIDEWALK	CURB HEIGHT	
	A2-6(6")	A2-8(8")
ADJACENT TO R/W	2'	3'
ADJACENT TO CURB	3'	4'
FULL PARKWAY	3'	4'

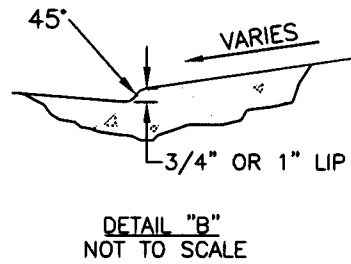
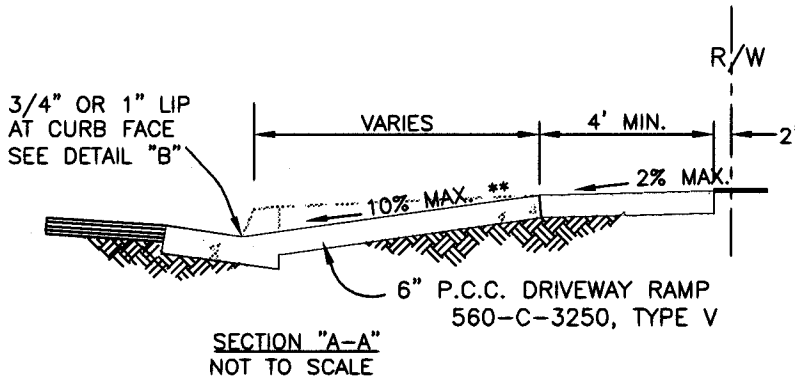
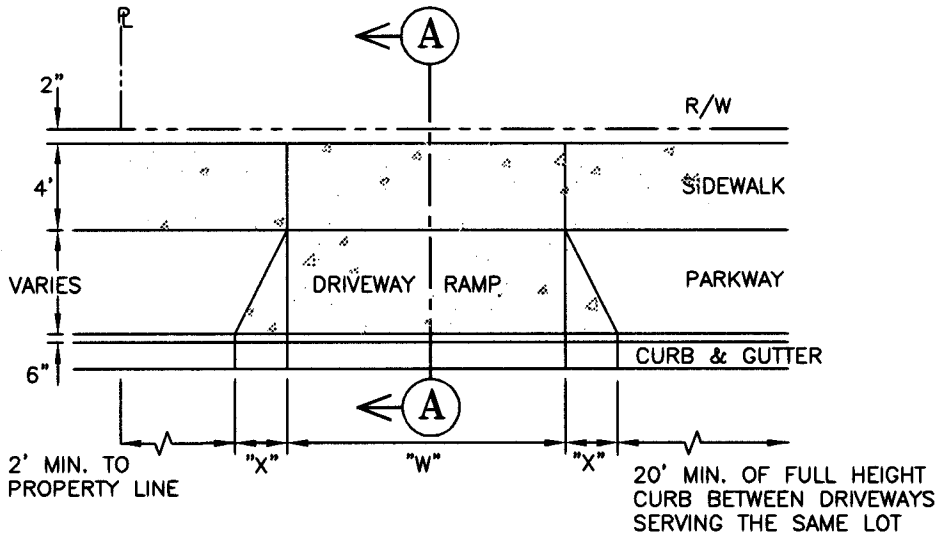

** MAXIMUM SLOPE MAY BE ADJUSTED TO MATCH EXISTING CONDITION.

D:\standards\ST Stds.dwg\ST-9.dwg 06/24/2002 11:12:33 AM PDT

APPROVED BY: W.E. CAMERON, CITY ENGINEER				23764 7-16-02 R.C.E. NO. DATE		 City of San Clemente Public Works Department - Engineering Division	
						STD.NO. ST-9	
				Residential Driveway Approach			
						SHEET 1 OF 4	
MARK	REVISIONS	APPR.	DATE				

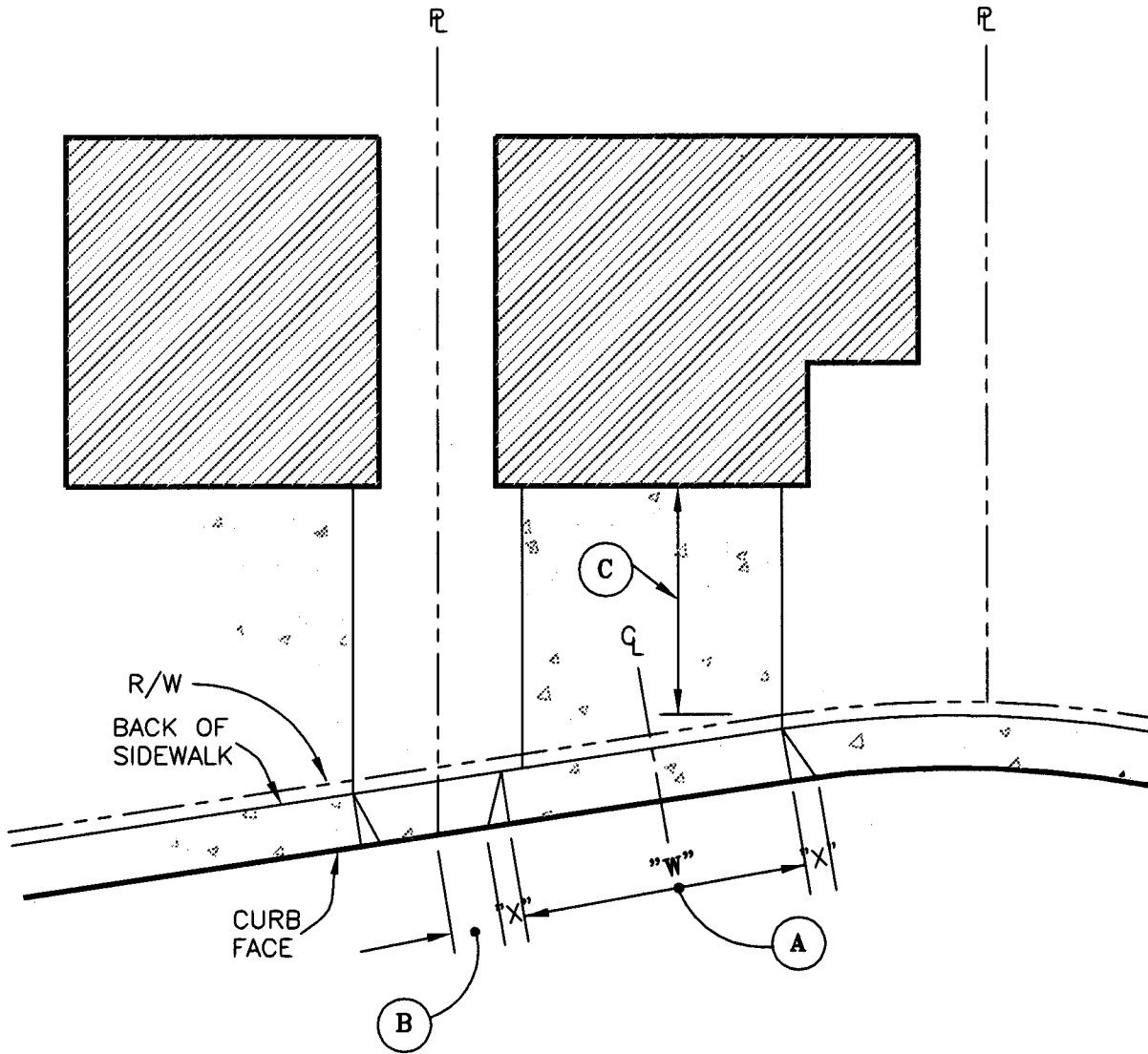

NOTES:

- (A) WIDTH OF DEPRESSION ("W"), SHALL BE DESIGNED USING PROJECTED DWY. LINES WHERE THEY INTERSECT BACK OF SIDEWALK AND/ OR CURB FACE. THE MINIMUM DIMENSION FOR ("W") SHALL BE WIDTH OF GARAGE DOOR OR 12 FEET WHICHEVER IS GREATER.
- (B) 2 FEET MIN. BETWEEN TOP OF "X" AND PROPERTY LINE.
- (C) DIMENSION SHALL BE A MINIMUM OF 20 FEET FROM RIGHT-OF-WAY LINE. DIMENSION SHALL BE A MINIMUM OF 18 FEET FROM RIGHT-OF-WAY LINE WITH "ROLL-UP" DOORS.

D:\standards\ST Stds\dwg\ST-9.dwg 06/24/2002 11:12:33 AM PDT

APPROVED BY: W.E. CAMERON, CITY ENGINEER				23764 R.C.E. NO.	7-16-02 DATE	 City of San Clemente Public Works Department - Engineering Division																				
<table border="1" style="width: 100%; border-collapse: collapse;"> <thead> <tr> <th style="width: 10%;">MARK</th> <th style="width: 40%;">REVISIONS</th> <th style="width: 15%;">APPR.</th> <th style="width: 15%;">DATE</th> </tr> </thead> <tbody> <tr><td> </td><td> </td><td> </td><td> </td></tr> <tr><td> </td><td> </td><td> </td><td> </td></tr> <tr><td> </td><td> </td><td> </td><td> </td></tr> <tr><td> </td><td> </td><td> </td><td> </td></tr> </tbody> </table>				MARK	REVISIONS	APPR.	DATE																	Residential Driveway Approach		STD.NO. ST-9
MARK	REVISIONS	APPR.	DATE																							
SHEET 2 OF 4																										

D:\standards\ST Stds\dwg\ST-9.dwg 06/24/2002 11:12:33 AM PDT

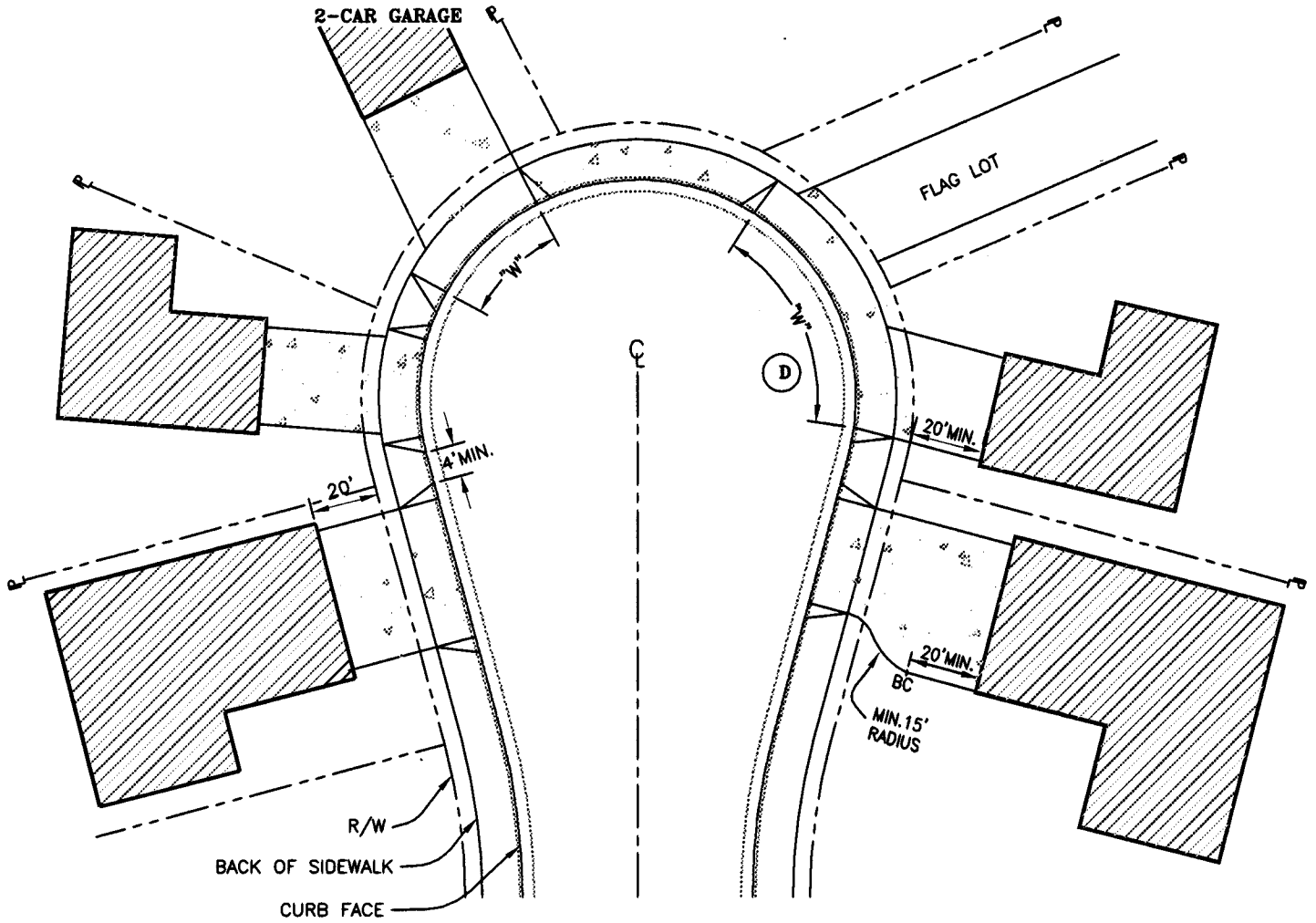

NOTES:

- (D) WHEN THE "X" OF ONE DRIVEWAY CONFLICTS WITH THE "X" OF AN ADJACENT DRIVEWAY IN A KNUCKLE OR CUL-DE-SAC, A COMMON DRIVEWAY SHALL BE USED.

APPROVED BY:

W.E. CAMERON, CITY ENGINEER 23764 7-16-02
 R.C.E. NO. DATE



City of San Clemente
 Public Works Department - Engineering Division

MARK	REVISIONS	APPR.	DATE
------	-----------	-------	------



**Residential
 Driveway Approach**

STD.NO.
ST-9
 SHEET 3 OF 4

NOTES:

1. RAMP THICKNESS SHALL BE 6" P.C.C., CLASS 560-C-3250, TYPE V CEMENT CONCRETE.
2. TWO (2) FEET MINIMUM OF FULL HEIGHT CURB SHALL BE MAINTAINED BETWEEN PROPERTY LINE AND TOP OF "X"
3. NO LESS THAN 20' OF FULL HEIGHT CURB SHALL BE MAINTAINED BETWEEN TWO DRIVEWAYS ON THE SAME PROPERTY.
4. THE TOTAL DRIVEWAY APPROACH WIDTH MAY NOT EXCEED 70% OF FRONTAGE PROPERTY LINE.
5. COLOR ADDITIVES OR PATTERN STAMPED CONCRETE SHALL NOT BE USED, EXCEPT WITHIN EXISTING AREAS WITH DECORATIVE SIDEWALK AS APPROVED BY THE CITY ENGINEER.
6. WHEN GARAGE DOOR OPENING AND RIGHT-OF-WAY LINE ARE PARALLEL AND DISTANCE BETWEEN GARAGE DOOR OPENING AND RIGHT-OF-WAY IS 20' OR LESS, DRIVEWAY WIDTH "W" SHALL BE A MINIMUM WIDTH EQUAL TO THE GARAGE DOOR OPENING AND SHALL BE CENTERED ON THE TOTAL GARAGE DOOR OPENING.
7. WHEN THE CLOSEST SETBACK DISTANCE BETWEEN THE GARAGE DOOR OPENING AND RIGHT-OF-WAY IS GREATER THAN 20'. "W" MAY BE REDUCED AND THE DRIVEWAY ON SITE MAY BE CURVED OR ANGLED AS NECESSARY PROVIDING A MINIMUM DISTANCE OF 20' IS MAINTAINED ADJACENT AND PERPENDICULAR TO THE GARAGE DOOR IN ORDER TO PROVIDE ROOM FOR A CAR TO BACK OUT OF THE GARAGE AND MANEUVER. REFER TO DETAIL ON SHEETS 3 of 4.
8. WHEN THE "X" OF ONE DRIVEWAY CONFLICTS WITH THE "X" OF AN ADJACENT DRIVEWAY IN A KNUCKLE OR CUL-DE-SAC, A COMMON DRIVEWAY SHALL BE USED.
9. A MINIMUM 5' CLEARANCE IS REQUIRED FROM TOP OF DRIVEWAY FLARE TO PARKWAY OBSTRUCTIONS (POLE, TREE, FIRE HYDRANTS, ETC.).
10. MINIMUM DISTANCE FROM TOP OF DRIVEWAY TO NEAREST CURB RETURN IS 25', UNLESS OTHERWISE APPROVED BY THE CITY ENGINEER.

D:\standards\ST Stds\dwg\ST-9.dwg 06/24/2002 11:12:33 AM PDT

APPROVED BY:  W.E. CAMERON, CITY ENGINEER				23764 R.C.E. NO.	7-16-02 DATE		City of San Clemente Public Works Department - Engineering Division	
				Residential Driveway Approach		STD.NO. ST-9		
MARK	REVISIONS	APPR.	DATE	Residential Driveway Approach		STD.NO. ST-9 SHEET 4 OF 4		

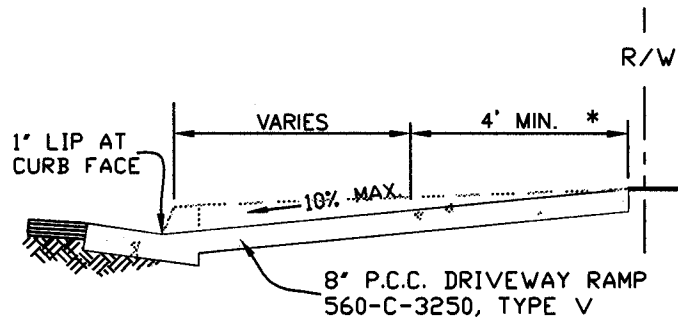
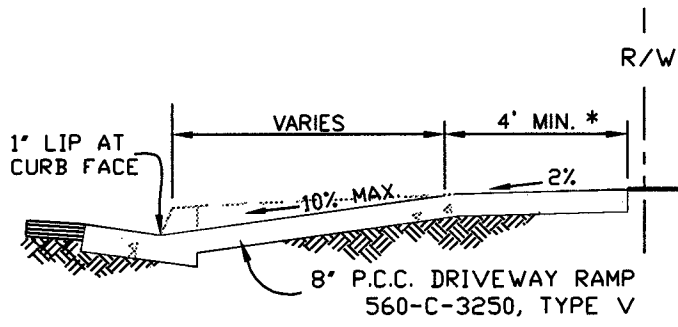
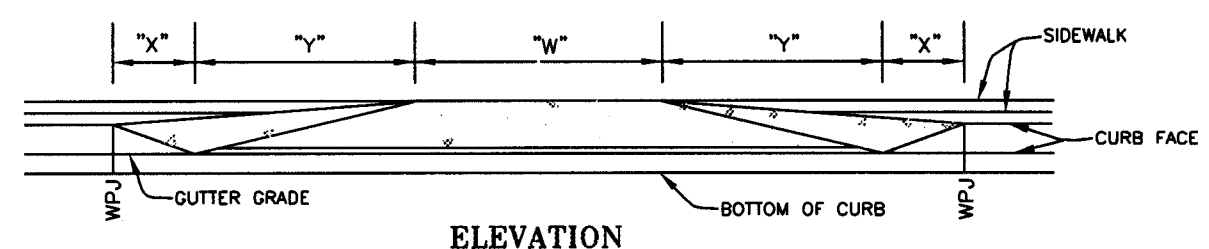
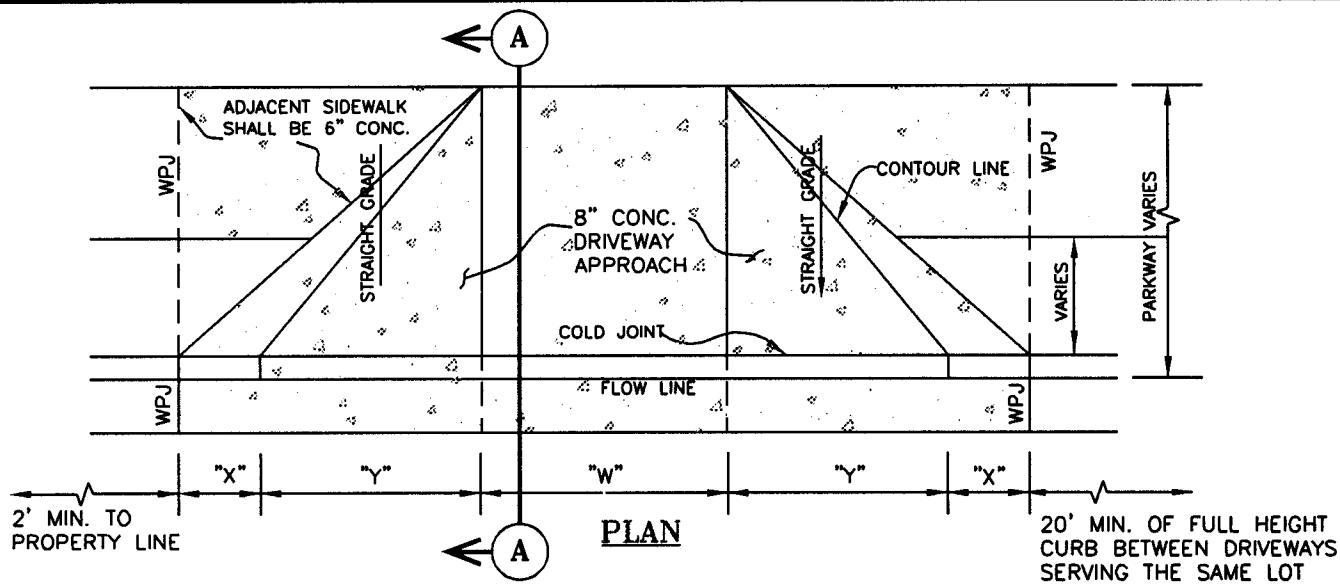

VALUES OF "X"		VALUES OF "Y" * *		VALUES OF "W"		
SIDEWALK	CURB HEIGHT	8' PARKWAY	8'-X	COMMERCIAL & INDUSTRIAL	MIN.	MAX.
	6"(A2-6) 8" (A2-8)	9' PARKWAY	9'-X		ONE-WAY	14'
ADJACENT TO R/W	2' 3'	10' PARKWAY	10'-X	TWO-WAY	28'	30'
ADJACENT TO CURB	3' 4'					
FULL PARKWAY	3' 4'					

* ALTERNATES IN RESIDENTIAL AREAS. COMMERCIAL AND INDUSTRIAL AREAS SHALL HAVE FULL PARKWAY SIDEWALK.
 * * VALUES OF "Y" MAY BE REDUCED UNDER CIRCUMSTANCES APPROVED BY THE CITY ENGINEER.

APPROVED BY: *W.E. Cameron*
 W.E. CAMERON, CITY ENGINEER 23764 7-16-02
 R.C.E. NO. DATE



City of San Clemente
 Public Works Department - Engineering Division

MARK	REVISIONS	APPR.	DATE

**Commercial & Industrial
 Driveway Approach**



STD.NO.
ST-10
 SHEET 1 OF 2

J:\standards\ST Stds\dwg\ST-8.dwg 10/02/01 08:03:57 AM PDT

NOTES:

1. RAMP THICKNESS FOR COMMERCIAL & INDUSTRIAL DRIVEWAY SHALL BE 8" P.C.C. CLASS 560-C-3250, TYPE V CEMENT CONCRETE.
2. TWO (2) FEET MINIMUM OF FULL HEIGHT CURB SHALL BE MAINTAINED BETWEEN PROPERTY LINE AND TOP OF "X"
3. NO LESS THAT 20' OF FULL HEIGHT CURB SHALL BE MAINTAINED BETWEEN TWO DRIVEWAYS ON THE SAME PROPERTY.
4. THE TOTAL WIDTH OF DEPRESSION ("W"+2"Y"), IN CASE MULTIPLE DRIVEWAYS ON A SINGLE OWNERSHIP PARCEL FRONTAGE, SHALL NOT EXCEED 70% OF THE FRONTAGE WHERE FRONTAGE IS 100' OR LESS, OR 60% WHERE FRONTAGE IS GREATER THAN 100'.
5. FRONTAGE LENGTH MINUS DEPRESSION WIDTH ("W"+2"Y") SHALL NOT BE LESS THAN 10'.
6. COMMERCIAL AND INDUSTRIAL DRIVEWAYS HAVING ANTICIPATED ADT IN EXCESS OF 1000 VEHICLES WILL BE DESIGNED AS LOCAL STREETS WITH CURB, SPANDREL AND CROSS GUTTER, SUBJECT TO APPROVAL OF ENGINEER.
7. COLOR ADDITIVES OR PATTERN STAMPED CONCRETE SHALL NOT BE USED, EXCEPT WITHIN EXISTING AREAS WITH DECORATIVE SIDEWALK AS APPROVED BY THE CITY ENGINEER.
8. A MINIMUM 2' CLEARANCE IS REQUIRED FROM TOP OF DRIVEWAY FLARE TO PARKWAY OBSTRUCTIONS (POLE, TREE, FIRE HYDRANTS, ETC.).
9. MINIMUM DISTANCE FROM TOP OF DRIVEWAY TO NEAREST CURB RETURN IS 25', UNLESS OTHERWISE APPROVED BY THE CITY ENGINEER.

D:\standards\ST Standards\ST-8.dwg 10/02/01 08:03:57 AM PDT

APPROVED BY:  W.E. CAMERON, CITY ENGINEER				23764 R.C.E. NO.	7-16-02 DATE	 <p>City of San Clemente Public Works Department - Engineering Division</p>	STD.NO. <h2 style="margin: 0;">ST-10</h2>																			
<table border="1" style="width: 100%; border-collapse: collapse;"> <thead> <tr> <th style="width: 10%;">MARK</th> <th style="width: 60%;">REVISIONS</th> <th style="width: 15%;">APPR.</th> <th style="width: 15%;">DATE</th> </tr> </thead> <tbody> <tr><td> </td><td> </td><td> </td><td> </td></tr> <tr><td> </td><td> </td><td> </td><td> </td></tr> <tr><td> </td><td> </td><td> </td><td> </td></tr> <tr><td> </td><td> </td><td> </td><td> </td></tr> </tbody> </table>				MARK	REVISIONS		APPR.	DATE																	<h2 style="margin: 0;">Commercial & Industrial Driveway Approach</h2>	
MARK	REVISIONS	APPR.	DATE																							

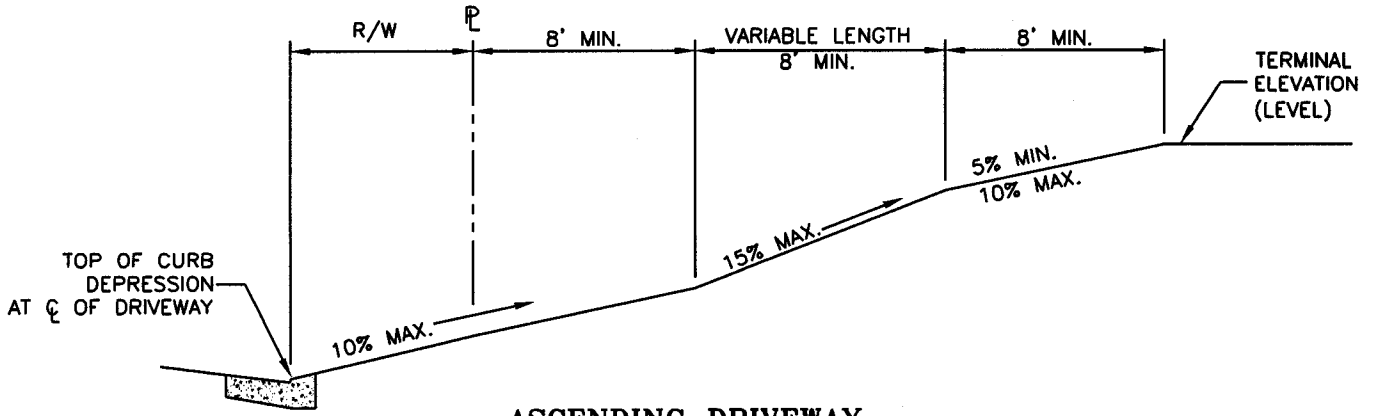

ASCENDING DRIVEWAY

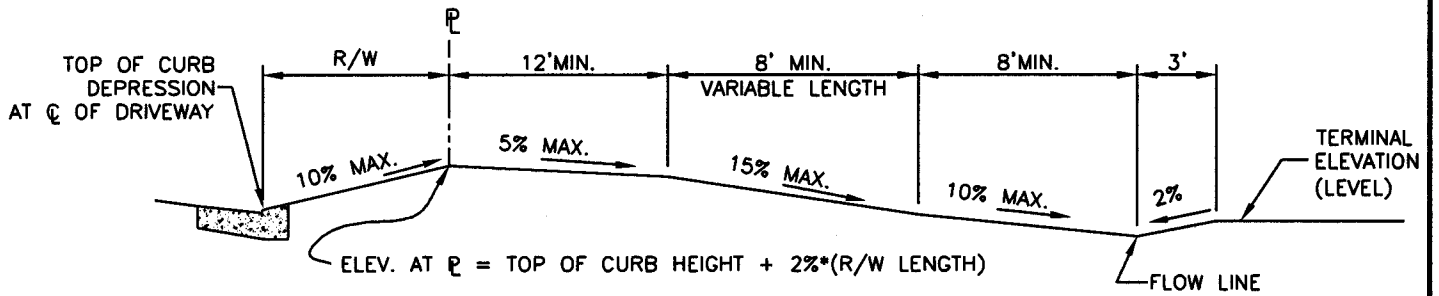

DESCENDING DRIVEWAY

P:\standards\ST-stds\stdg\ST-9.dwg 10/04/01 09:28:27 AM PBT

APPROVED BY:

W.E. Cameron
W.E. CAMERON, CITY ENGINEER

23764
R.C.E. NO.

7-16-02
DATE



City of San Clemente
Public Works Department - Engineering Division

MARK	REVISIONS	APPR.	DATE

Driveway Grades

STD.NO.
ST-11

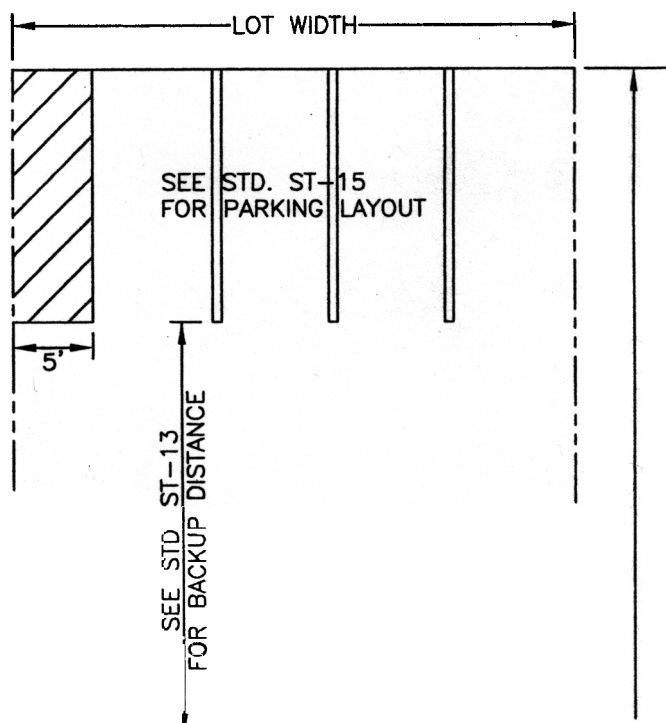

NOTES:

PARKING LOT PAVEMENT SECTION SHALL BE DETERMINED BY SOILS R-VALUE TEST AND BY T.I.

- 2. MINIMUM SECTION FOR DRIVEWAY AISLE SHALL BE 4" A.C. OVER 7" C.A.B. OR 6" P.C.C. OR 7.5" FULL DEPTH A.C.
- 3. MINIMUM SECTION FOR PARKING STALLS SHALL BE 3" A.C. OVER 6" C.A.B.
- 4. LOTS 40 FT. WIDE OR LESS, BOTTOM OF "X" CAN BE ALIGNED WITH THE PROPERTY LINE.

△5.

PROJECT TYPES	MIN. DRIVEWAY AISLE WIDTH
SINGLE FAMILY; DUPLEX LOTS	12 FT.
TRIPLEX LOTS	16 FT.
△ MU3 AND NC2 ZONES, LOTS 60 FT. WIDE OR LESS	16 FT.
△ MU3 AND NC2 ZONES, LOTS BETWEEN 60 FT AND 80 FT.	20 FT.
FOURPLEX LOTS	20 FT.
MULTI-FAMILY (5 UNITS OR MORE); COMMERCIAL LOTS	24 FT.
△ MU3 AND NC2 ZONES, LOTS WIDER THAN 80 FT.	24 FT.

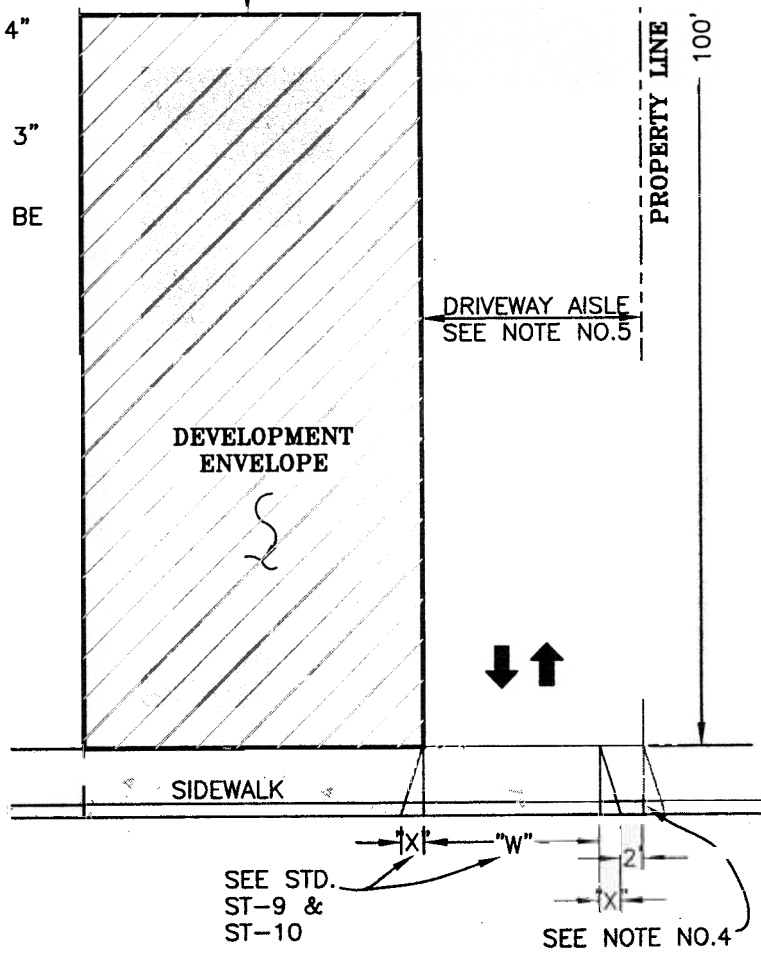

D:\stanana\dwg\technical\std\dwg\ST-12.dwg 07/01/2003 09:26:58 AM PDT

APPROVED BY: *W.E. Cameron* 23764 12-14-04
 W.E. CAMERON, CITY ENGINEER R.C.E. NO. DATE

 **City of San Clemente**
 Public Works Department - Engineering Division

MARK	REVISIONS	APPR.	DATE
△	ADDED DRIVEWAY WIDTHS FOR TRIPLEX, FOURPLEX, AND 5 UNIT LOTS.	<i>WEC</i>	7-1-03
△	ADDED NC2 ZONE TO PROJECT TYPES.	<i>WEC</i>	12-14-04

STD.NO.
Parking Circulation ST-12

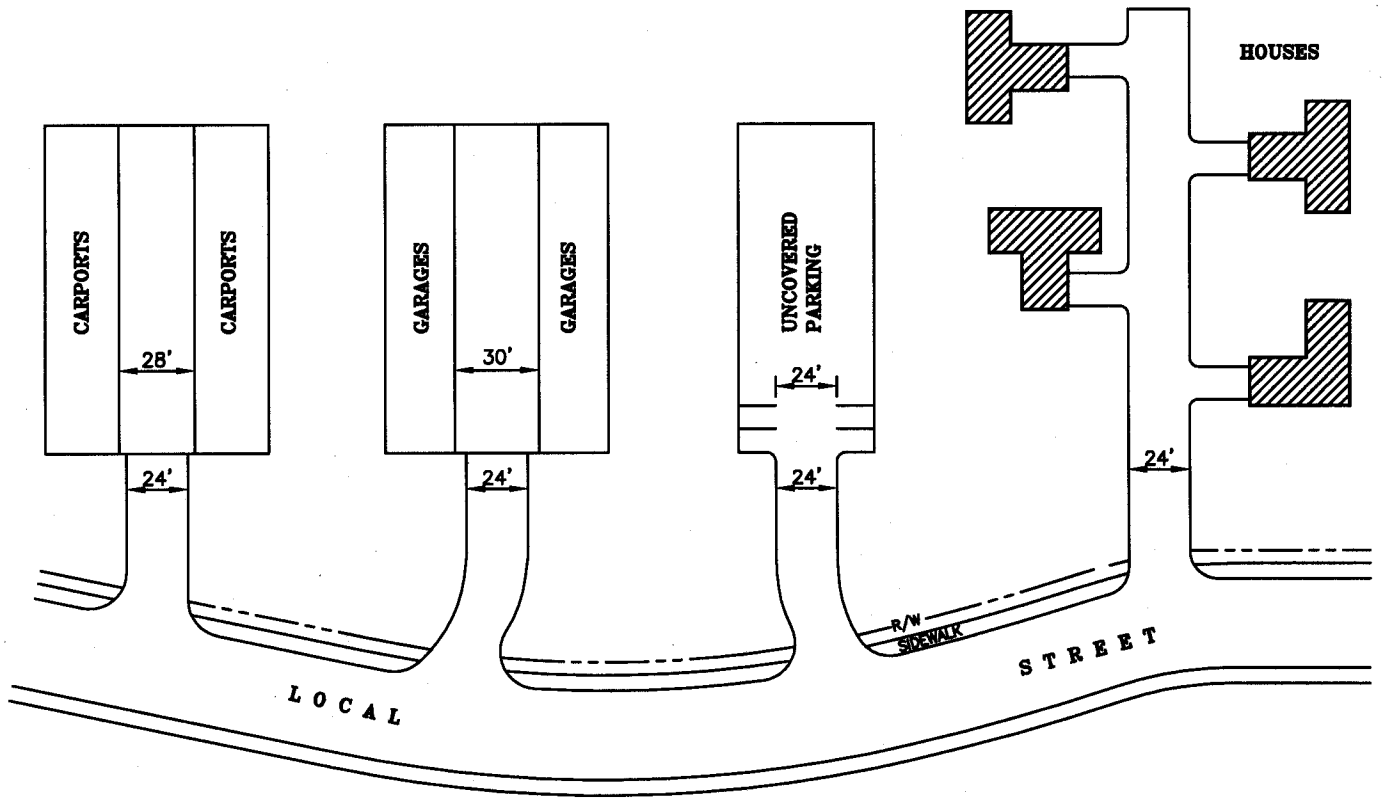

NOTES:

1. THE NUMBER AND SIZE OF PARKING SPACES PROVIDED FOR ANY DEVELOPMENT SHALL CONFORM WITH THE CITY REQUIREMENTS.
2. PARKING, OTHER THAN PARALLEL ON-STREET, SHALL BE PROVIDED WITHIN PARKING LOTS AND PARKING BAYS. DIAGONAL AND PERPENDICULAR PARKING SPACES ARE NOT ALLOWED ON STREETS EXCEPT WITH THE APPROVAL OF THE CITY ENGINEER.
3. ACCESS DRIVES AND DRIVEWAYS SERVING PARKING LOTS SHALL PROVIDE A MINIMUM 24' TRAVEL WAY.
4. BACKUP DISTANCE BETWEEN ROWS OF PERPENDICULAR PARKING SHALL BE 24' WIDE MINIMUM. BACKUP DISTANCE BETWEEN ROWS OF COVERED PARKING SHALL BE 28' WIDE MINIMUM. BACKUP DISTANCE BETWEEN ROWS OF FACING GARAGES SHALL BE 30' WIDE MINIMUM. BACKUP DISTANCE FOR LOTS 50' WIDE OR LESS THAT ARE LOCATED WITHIN NEIGHBORHOOD COMMERCIAL ZONES (NC) SHALL BE 22' WIDE MINIMUM. BACKUP DISTANCE FOR LOTS 40' WIDE OR LESS THAT ARE LOCATED WITHIN DOWNTOWN MIXED-USED ZONE (MU3) SHALL BE 22' WIDE MINIMUM. LOT WIDTH SHALL BE MEASURED AS DEFINED BY THE ZONING ORDINANCE.
5. VEHICLES ARE NOT ALLOWED TO BACKUP WITHIN THE AISLE MORE THAN 30 FEET.
6. JOINTLY-USES PRIVATE DRIVEWAYS SERVING 2 OR MORE RESIDENTIAL DWELLING UNITS SHALL BE PAVED TO A MINIMUM WIDTH OF 24'.
7. MINIMUM PRIVATE DRIVEWAY GRADES SHALL BE 2.0%.
8. BACKUP DISTANCE MUST BE CLEAR OF ANY STRUCTURES OR PARKING STALLS.
9. PARKING SPACE ADJACENT TO A WALL, BUILDING, OR FENCE SHALL BE 11.5' WIDE.
10. THREE-POINT TURNS TO ENTER PARKING STALLS ARE NOT ALLOWED EXCEPT IN MIXED-USE ZONES (MU3) FOR 60' WIDE LOTS OR LESS ONLY.

D:\Standard Dwg\Technical Std Dwg\ST-13 Rev.dwg 06/07/2004 10:55:41 AM PBT

APPROVED BY:

W.E. Cameron
W.E. CAMERON, CITY ENGINEER

23764 11-11-05
R.C.E. NO. DATE



City of San Clemente

Public Works Department - Engineering Division

△	ADDED BACKUP DISTANCE FOR NC AND MU 3 ZONES.	WEC	6-16-09
△	ADDED GUIDELINES FOR AISLE BACKUP AND THREE-POINT TURNS.	WEC	11-11-05
MARK	REVISIONS	APPR.	DATE

**Parking Aisles
and Driveways**

STD.NO.

ST-13

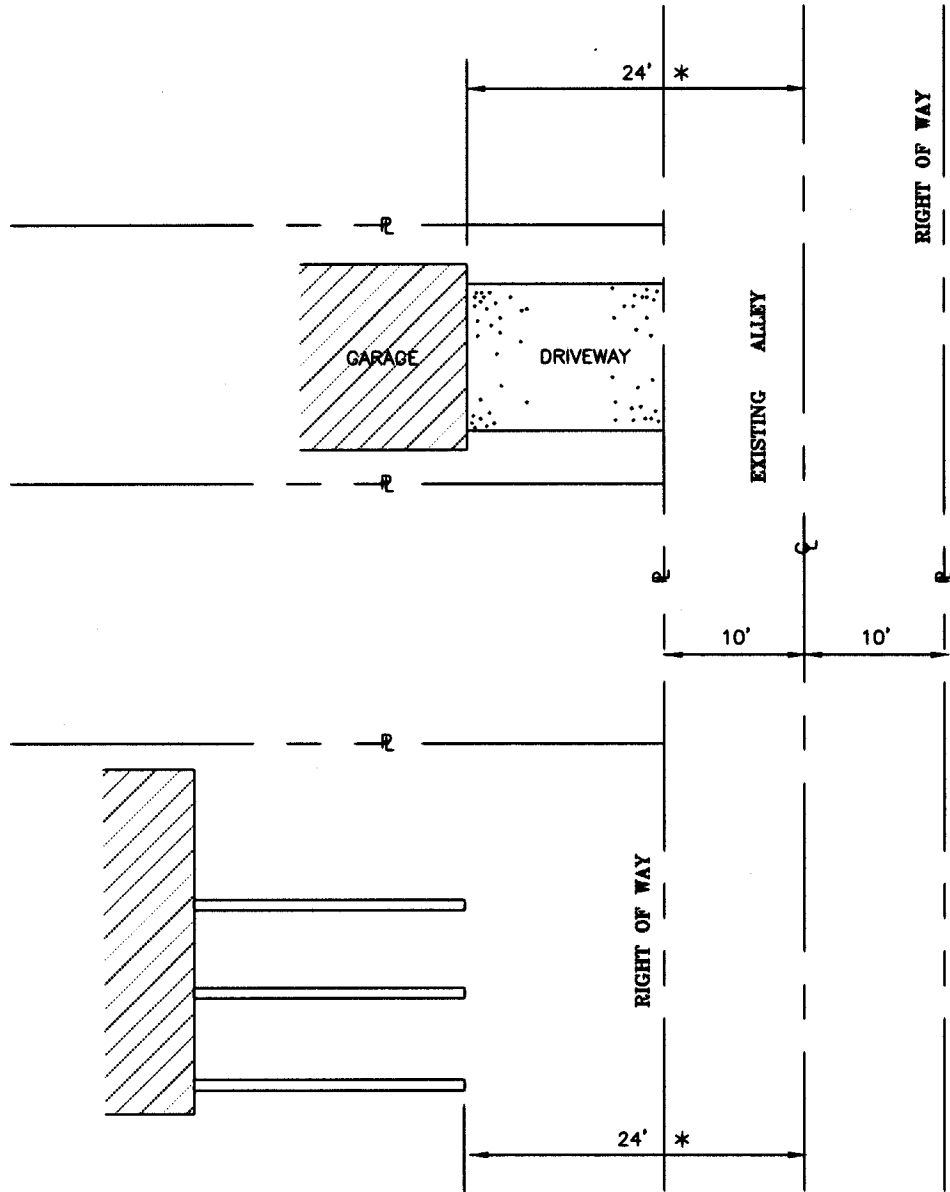

* 24' MIN. MAY BE WAIVED BY THE CITY ENGINEER BASED ON LINE-OF-SIGHT, OBSTRUCTIONS AND FOR OTHER CONSTRAINTS.

D:\standards\ST_Std\dwg\ST-14.dwg 06/24/2002 03:05:47 PM PBT

APPROVED BY:

W.E. Cameron
 W.E. CAMERON, CITY ENGINEER

23764 7-16-02
 R.C.E. NO. DATE



City of San Clemente
 Public Works Department - Engineering Division

MARK	REVISIONS	APPR.	DATE

**Parking Spaces
 Backing into Alley**

STD.NO.
ST-14

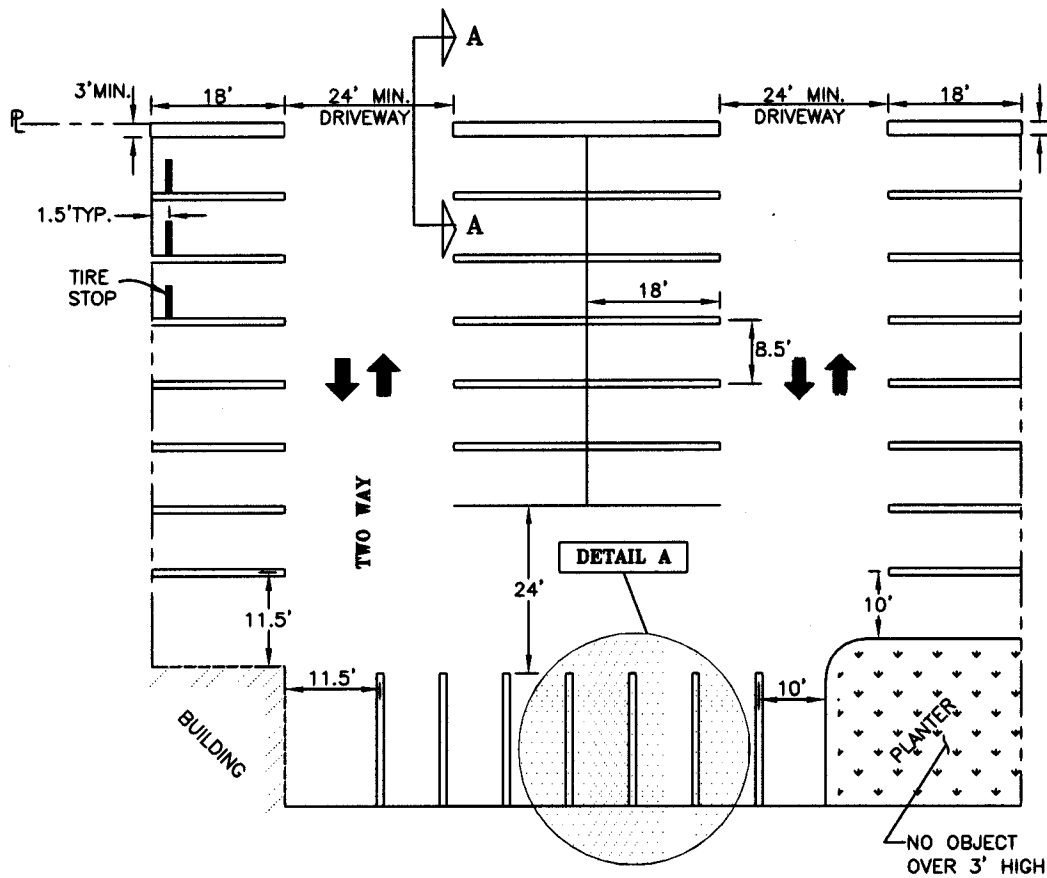

PERPENDICULAR PARKING

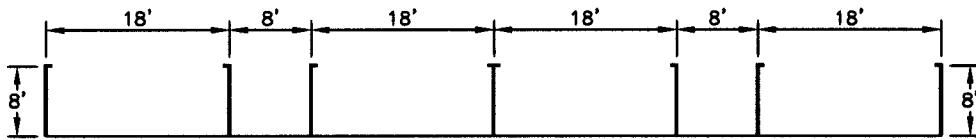

PARALLEL PARKING

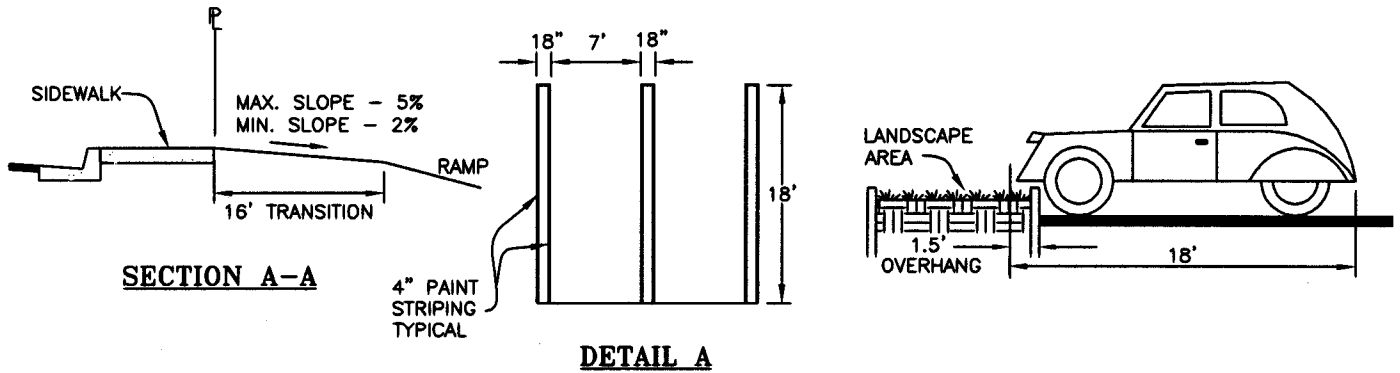

D:\standards\ST-15.dwg 06/24/2002 03:10:32 PM PDT

APPROVED BY:

 W.E. CAMERON, CITY ENGINEER 23764 7-16-02
 R.C.E. NO. DATE



City of San Clemente
 Public Works Department - Engineering Division

MARK	REVISIONS	APPR.	DATE

Parking Standards

STD.NO.
ST-15
 SHEET 1 OF 2

A	B	C	D
20°	24.9'	14.2'	18'
30°	17.0'	16.4'	18'
45°	12.0'	18.8'	18'
60°	9.8'	19.9'	18'
70°	9.1'	19.9'	20'
80°	8.6'	19.2'	22'
90°	8.5'	18.0'	24'

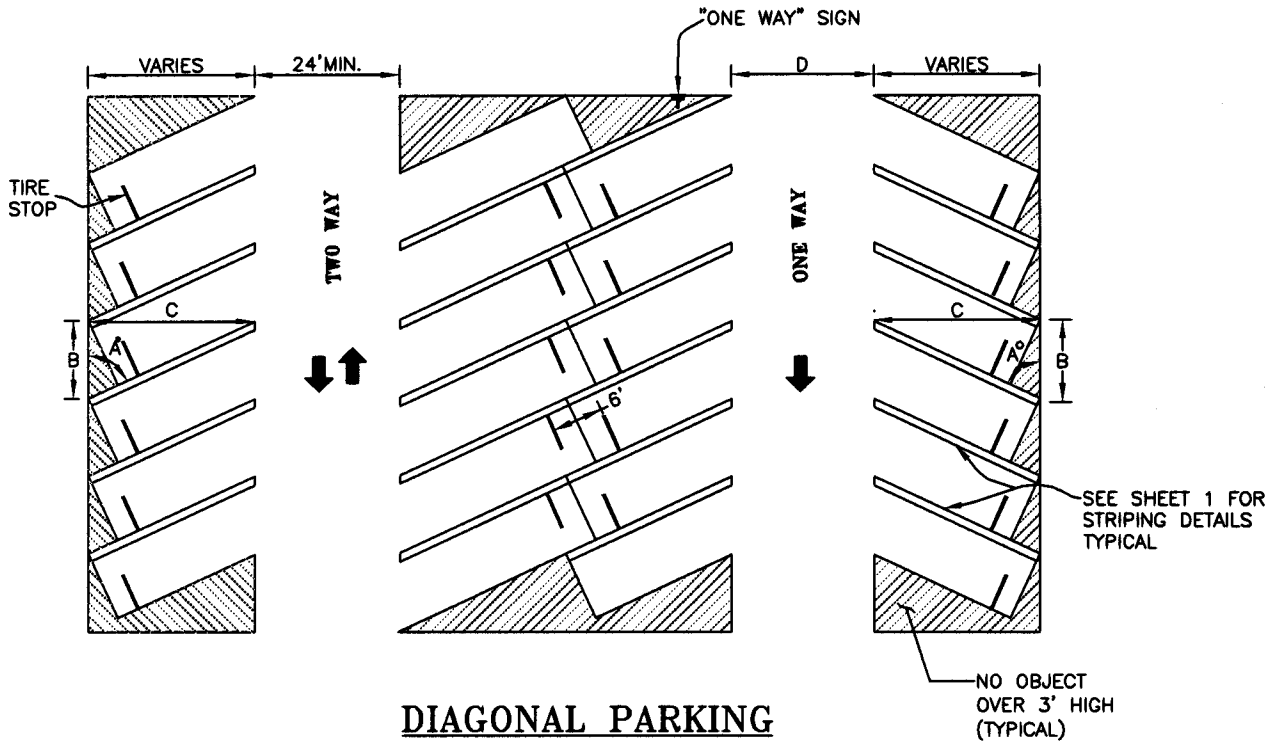

DIAGONAL PARKING

NOTES:

1. PARKING SPACE ADJACENT TO A WALL, BUILDING OR FENCE SHALL BE 11.5' WIDE. PARKING SPACE ADJACENT TO A PLANTER AREA SHALL BE 10.0' WIDE.
2. A RAMPED DRIVEWAY EXIT RISING UP TO A PUBLIC SIDEWALK MUST HAVE A TRANSITION SECTION THAT IS ALMOST LEVEL (MAXIMUM SLOPE: 5%) BEFORE INTERSECTING THE SIDEWALK TO PREVENT THE HOOD OF THE CAR FROM OBSCURING THE DRIVER'S VIEW. THIS TRANSITION SHOULD BE 16 FEET LONG.
3. PARKING LOT MAY NOT DRAIN OVER DRIVEWAY. ALL DRAINAGE MUST BE CONVEYED THROUGH AN APPROVED DRAINAGE SYSTEM.
4. CROSS GUTTERS MAY NOT CROSS DRIVEWAY LANES. GUTTERS MUST BE PLACED IN FRONT OR BACK OF PARKING STALLS UNLESS APPROVED BY THE CITY ENGINEER.
5. A TURN AROUND IS REQUIRED IF THE NUMBER OF PARKING SPACES EXCEEDS 10.

D:\standards\ST-Std\dwg\ST-15.dwg 06/24/2002 09:10:32 PM PDT

APPROVED BY:

W.E. Cameron
W.E. CAMERON, CITY ENGINEER

23764 7-16-02
R.C.E. NO. DATE



City of San Clemente
Public Works Department - Engineering Division

MARK	REVISIONS	APPR.	DATE

Parking Standards

STD.NO.

ST-15

SHEET 2 OF 2

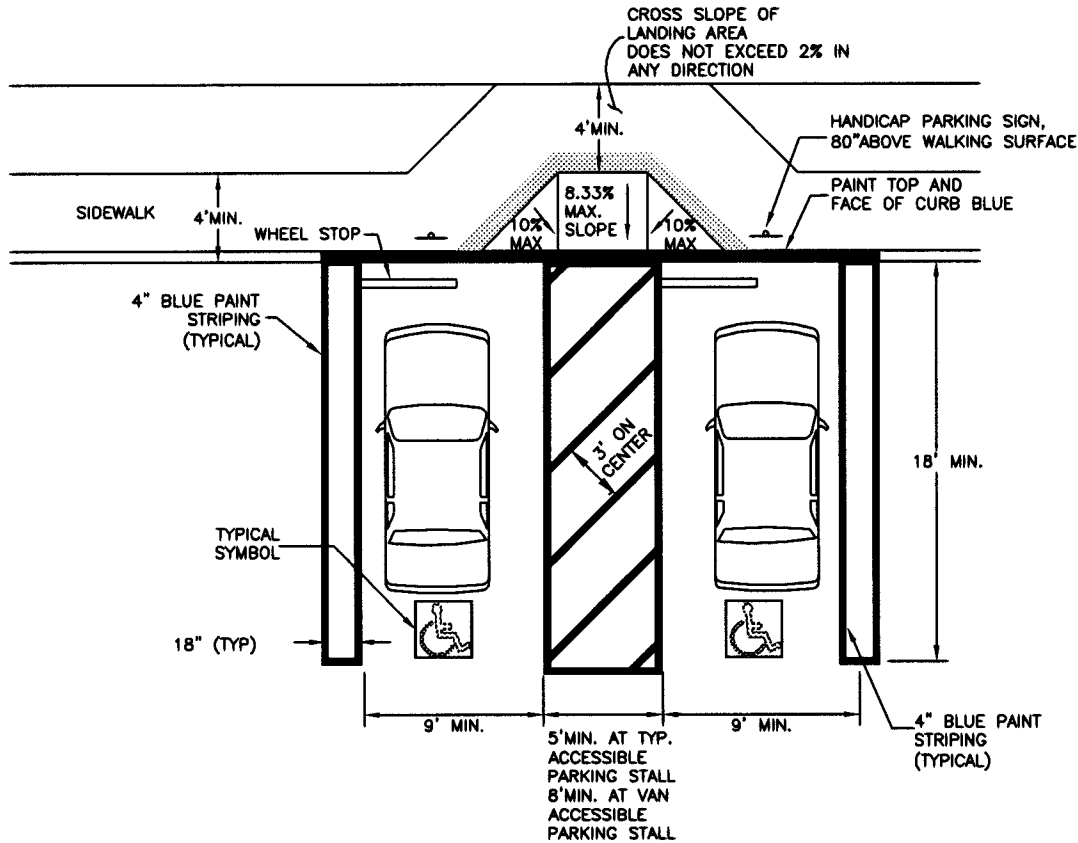
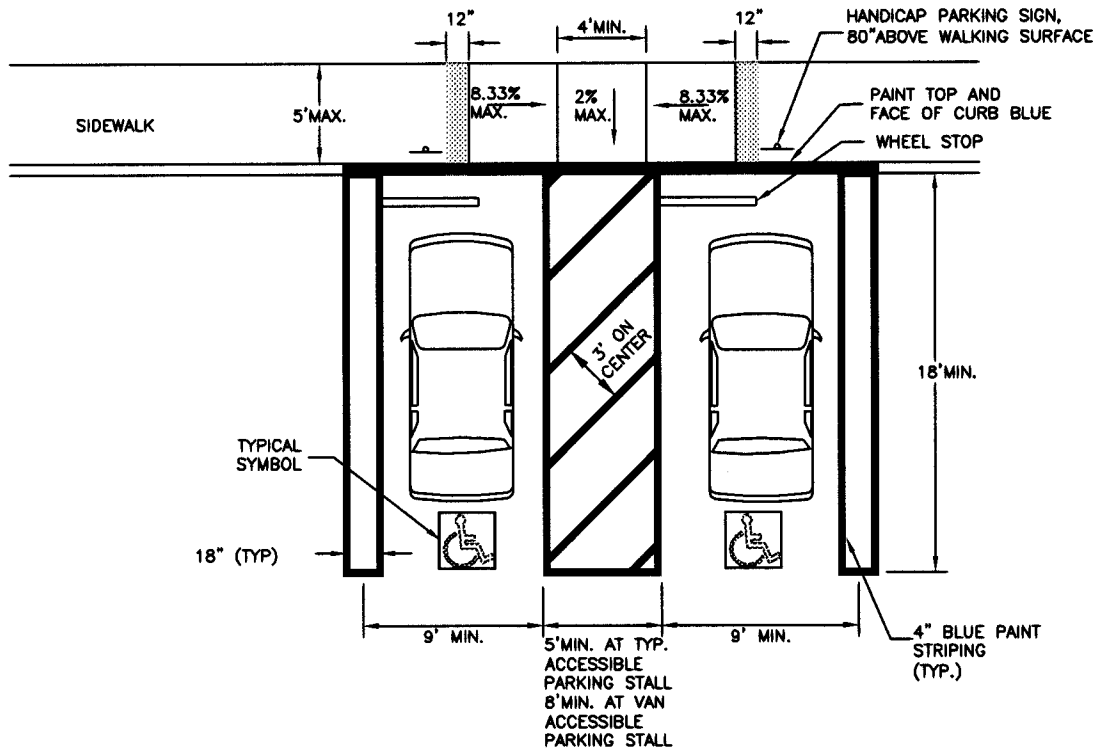

D:\standards\ST Standards\ST-16.dwg 06/24/2002 03:21:47 PM PDT

APPROVED BY: W.E. Cameron 23764 7-16-02
 W.E. CAMERON, CITY ENGINEER R.C.E. NO. DATE



City of San Clemente
 Public Works Department - Engineering Division

MARK	REVISIONS	APPR.	DATE



A.D.A. Parking Standards

STD.NO.
ST-16
 SHEET 1 OF 2

NOTES:

1. CURB RAMP REQUIRED WHEN WALK IS AT DIFFERENT LEVEL THAN PARKING ELEVATION. RAMPS ARE NOT ALLOWED TO ENCROACH INTO LOADING/UNLOADING ZONES, PARKING SPACES OR VEHICULAR TRAFFIC LANES.
2. ONE IN EVERY EIGHT ACCESSIBLE OFF-STREET PARKING STALLS, BUT NOT LESS THAN ONE, SHALL BE SERVED BY AN ACCESSIBLE AISLE OF 8' MINIMUM WIDTH TO BE PLACED ON THE PASSENGER SIDE AND SIGNED "VAN ACCESSIBLE" PER CALTRAN STANDARD SPECIFICATIONS.
3. PARKING SPACE(S) AND ACCESS AISLE(S) GRADES SHALL NOT EXCEED 2% IN ANY DIRECTION.
4. ACCESSIBLE PARKING STALLS SHALL BE LOCATED AS CLOSE AS POSSIBLE, AND ON THE SHORTEST ACCESSIBLE ROUTE OF TRAVEL, TO THE PEDESTRIAN ENTRANCE OR EXIT OF THE PARKING LOT OR GARAGE.
5. GROOVED BORDER MUST BE ON THE LEVEL SURFACE AT THE TOP OF THE RAMP.

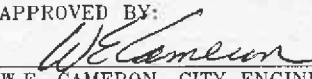
J:\standards\ST_Standards\ST-16.dwg 06/24/2002 03:21:47 PM PDT

APPROVED BY:  W.E. CAMERON, CITY ENGINEER				23764 R.C.E. NO.	7-16-02 DATE	 City of San Clemente Public Works Department - Engineering Division	
				A.D.A. Parking Standards		STD.NO. ST-16	
MARK	REVISIONS	APPR.	DATE			SHEET 2 OF 2	

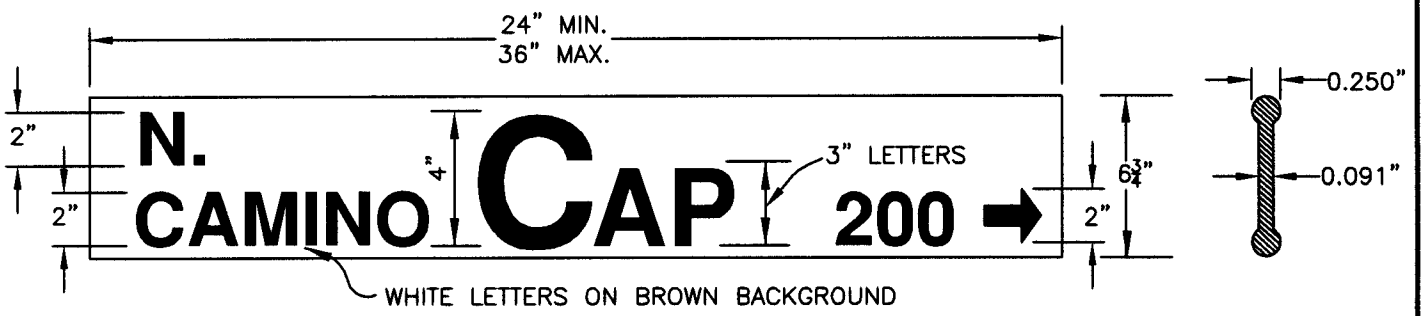
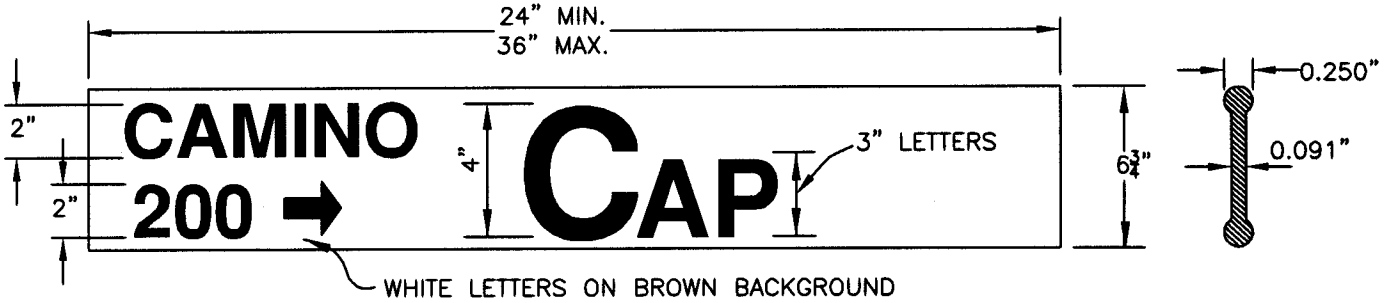

D:\standards\ST Std\dwg\ST-17.dwg 06/24/2002 09:27:11 PM PBT

APPROVED BY: *W.E. Cameron*
 W.E. CAMERON, CITY ENGINEER 23764 7-16-02
 R.C.E. NO. DATE



City of San Clemente
 Public Works Department - Engineering Division

MARK	REVISIONS	APPR.	DATE

Street Name Signs

STD.NO.
 ST-17
 SHEET 1 OF 3

D:\standards\ST_Std\dwg\ST-17.dwg 06/24/2002 03:27:11 PM PDT

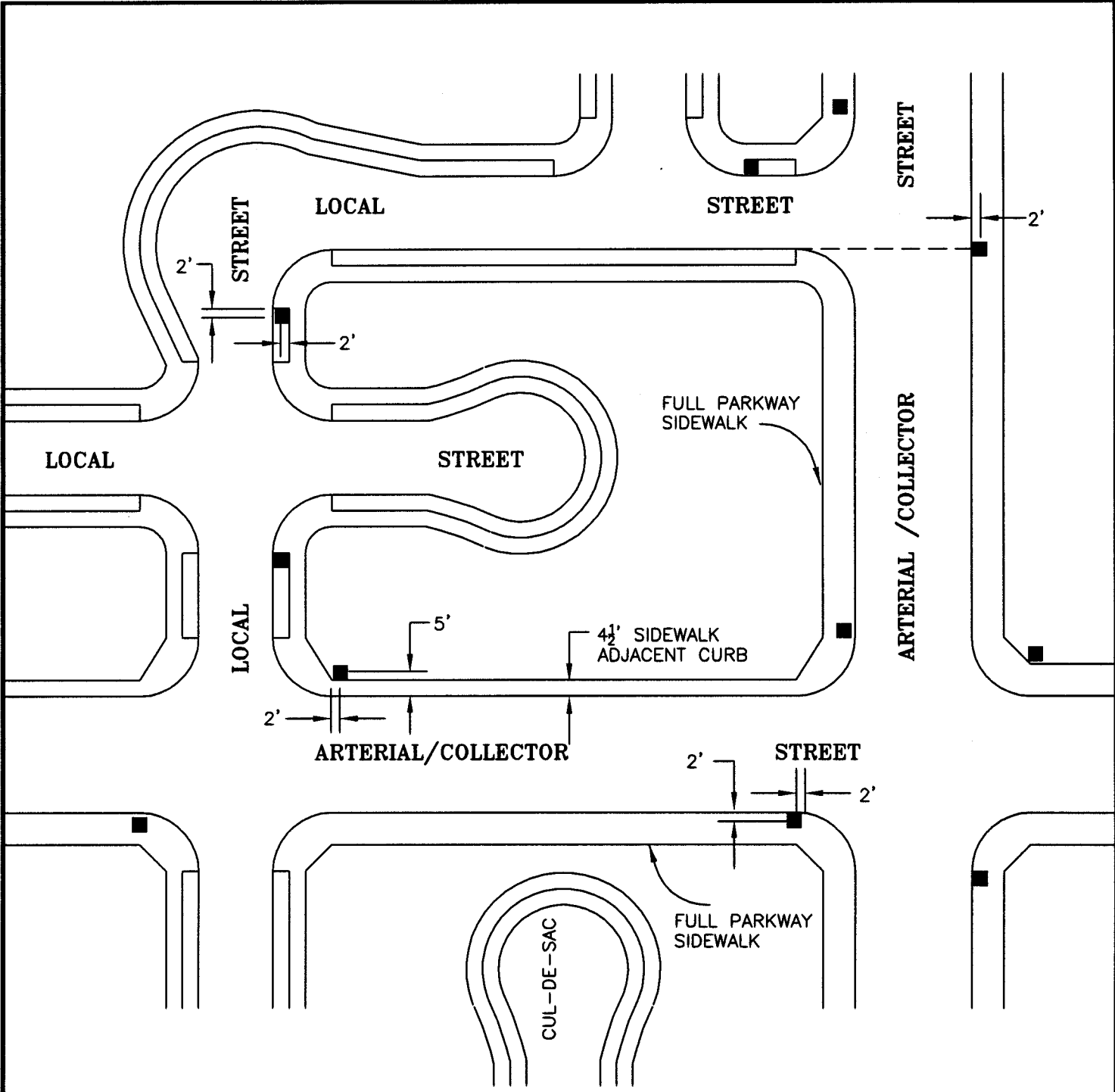

LEGEND:

■ = TWO 6 3/4" SIGNS.

APPROVED BY: *W.E. Cameron*
 W.E. CAMERON, CITY ENGINEER 23764 7-16-02
 R.C.E. NO. DATE



City of San Clemente
 Public Works Department - Engineering Division

MARK	REVISIONS	APPR.	DATE



Street Name Signs

STD.NO.
ST-17
 SHEET 2 OF 3

NOTES:

1. ARTERIAL, COLLECTOR AND LOCAL STREET NAME SIGNS SHALL BE 6-3/4" WIDE BLADE WITHOUT HOLES CONFORMING TO ALUMINUM ALLOY 5052-H38 IN VARIOUS LENGTHS TO ACCOMMODATE THAT MESSAGE UP TO 36" MAXIMUM OR WITH THE APPROVAL OF THE CITY ENGINEER, OR DESIGNEE.
2. THE BLADE SHALL BE EXTRUDED WITH A 0.091" CENTER THICKNESS AND 0.250" EDGE THICKNESS.
3. THE REFLECTIVE SHEETING SHALL BE ENCAPSULATED LENS REFLECTIVE SHEETING, AS DESCRIBED IN STATE OF CALIFORNIA DEPARTMENT OF TRANSPORTATION SPECIFICATIONS, REVERSE SCREENED USING 3M BRAND #887 BROWN INK, OR 3M1177EX FILM.
4. THE STREET NAME LAYOUT SHALL BE WHITE COPY ON BROWN BACKGROUND.
5. THE STREET NAME LETTER COPY SHALL BE 4" UPPER CASE AND 3" LOWER CASE. PREFIX OR SUFFIX LETTER COPY SHALL BE 2" UPPER CASE. BLOCK NUMBERS AND DIRECTIONAL ARROWS SHALL BE 2". ALL COPY SHALL BE SERIES "C".
6. BLOCK NUMBERS SHALL BE SCREENED "00" WITH REMAINING NUMBERS TO BE ADDED USING DIE CUT COPY.
7. PREFIX AND SUFFIX LETTER COPY (CAMINO, AVENIDA, CALLE, VIA, ST, etc.) SHALL BE REVERSED SCREENED, OR DIE CUT SERIES "C" COPY.
8. THE STREET NAME MAY BE REVERSE SCREENED OR DIE CUT SERIES "C" COPY.
9. THE STREET NAME SHALL BE CENTERED ON THE SIGN FACE.
10. THE STREET NAME SIGN SHALL HAVE DOUBLE-FACED MESSAGE.
11. MOUNTING HARDWARE SHALL BE TRAFFIC SAFETY COMPANY MODEL #808, 2" WITH THEFT PROOF BOLTS MILLED TO ACCOMMODATE 0.250" THICKNESS EXTRUDED BLADE WITH HIGH INTENSITY SHEETING OR SUPR-LOK PRUF BRACKETS WITH VANDAL PROOF BOLTS OR EQUIVALENT.
12. ALL SIGN POSTS SHALL BE STEEL TUBE IN COMPLIANCE WITH ORANGE COUNTY PUBLIC FACILITIES AND RESOURCES DEPARTMENT STANDARD 1417.
13. EXACT LOCATION OF STREET NAME TO BE SHOWN ON SEPARATE STRIPING AND SIGNAGE PLANS.
14. STREET NAME SIGNS SHALL BE PLACED AT THE NEAR RIGHT APPROACH OF MAJOR TRAFFIC FLOW. ONE SIGN SHALL BE PLACED AT THE INTERSECTION OF TWO LOCAL STREETS. TWO SIGNS SHALL BE PLACED AT THE INTERSECTION OF AN ARTERIAL/COLLECTOR STREET WITH A LOCAL STREET. FOUR SIGNS SHALL BE PLACED AT THE INTERSECTION OF TWO ARTERIAL/COLLECTOR STREETS.
15. SIGNS BLADE SHALL BE PLACED MINIMUM OF 12" FROM CURB FACE.

J:\standards\ST Stds\dwg\ST-17.dwg 06/24/2002 03:27:11 PM PDT

APPROVED BY:  W.E. CAMERON, CITY ENGINEER				23764 R.C.E. NO.	7-16-02 DATE	 City of San Clemente Public Works Department - Engineering Division	
				Street Name Signs		STD.NO. ST-17	
MARK	REVISIONS	APPR.	DATE			SHEET 3 OF 3	

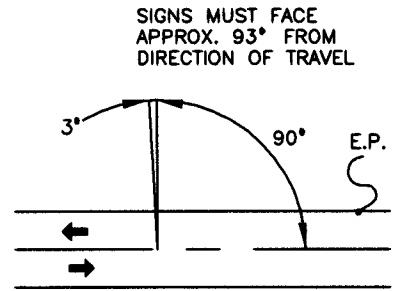
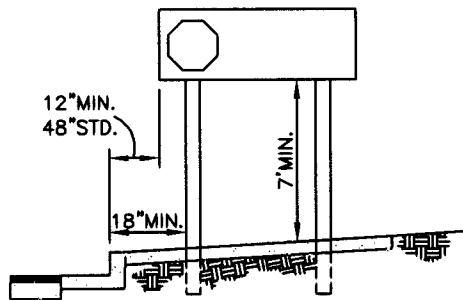
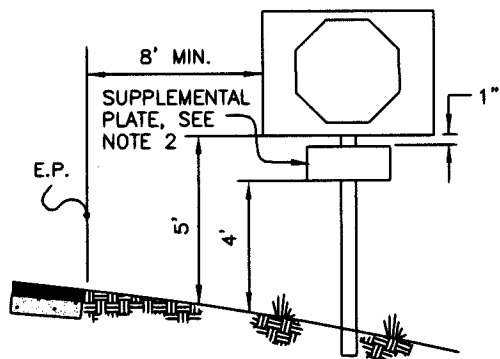
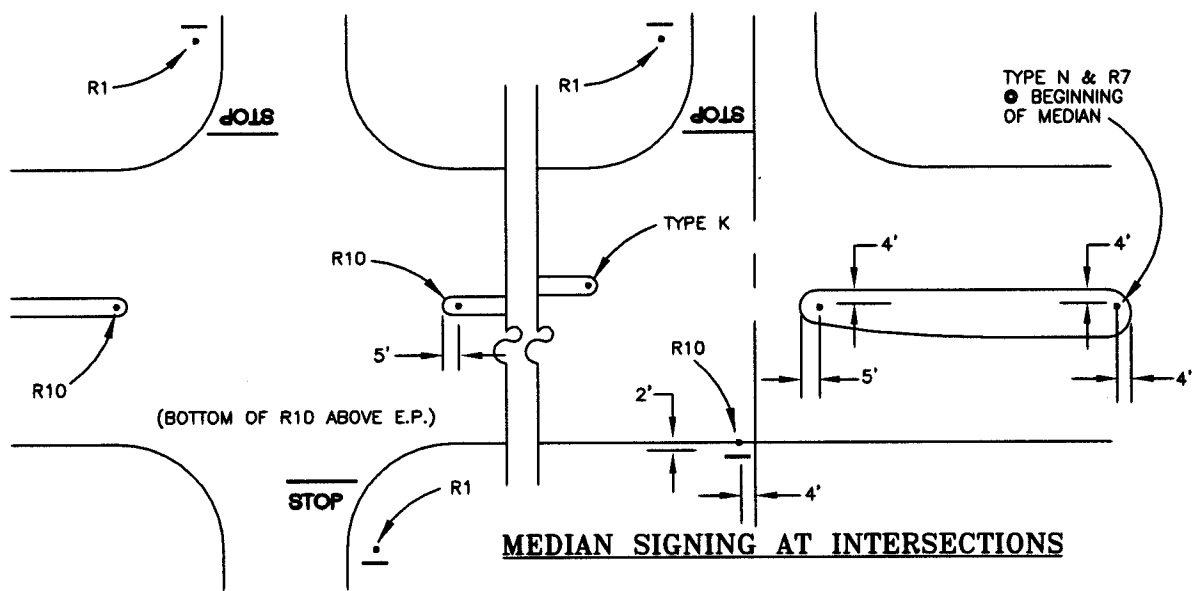

NOTES:

1. SEE SHOULDER AND PARKWAY LOCATION DETAILS FOR STANDARD MOUNTING HEIGHTS. EXCEPTIONS SHOULD BE MADE TO AVOID SIGHT RESTRICTIONS OR UNDESIRABLE CONDITIONS, AT THE DIRECTION OF THE ENGINEER.
2. WHEN SUPPLEMENTAL PLATE IS USED, THE 4' MOUNTING HEIGHT SHALL SUPERSEDE THE 5' MOUNTING HEIGHT AT SHOULDER LOCATIONS.
3. SEE THE LATEST STATE OF CALIFORNIA TRAFFIC MANUAL FOR R1, R7, R10, TYPE K AND TYPE N DETAILS. SIGNALS SHALL BE STANDARD SIZE UNLESS OTHERWISE NOTED. R1 AND TYPE N SIGNS SHALL BE FACED WITH HIGH INTENSITY OR EQUIVALENT GRADE REFLECTIVE MATERIAL, MEETING STATE OF CALIFORNIA DEPARTMENT OF TRANSPORTATION STANDARD SPECIFICATIONS SECTION 718, REFLECTIVE SHEETING.
4. PARKWAY AND SHOULDER SIGNS HAVING A HORIZONTAL WIDTH 48" OR GREATER SHALL BE DUAL-POST MOUNTED. SIGNS LESS THAN 48" IN WIDTH SHALL BE MOUNTED ON A SINGLE POST. POST(S) SHALL BE SQ. PERFORATED STEEL TUBING WITH BREAKWAY BASE EXCEPT WHEN MOUNTED ON SAME POST AS STREET NAME SIGN. SEE PLAN VIEW FOR ANGULAR PLACEMENT OF SIGNS. SEE PLAN 1417 FOR SQ. PERFORATED STEEL TUBING DETAIL.
5. ADVANCE STREET NAME SIGNS PLACED IN MEDIANS SHALL BE 2' FROM THE EDGE OF THE TRAVELED WAY, AND BE LOCATED APPROXIMATELY 300' FROM THE INTERSECTION OR 100' FROM THE BEGINNING OF A LEFT TURN POCKET. SIGN MOUNTING HEIGHT SHALL BE 5' ABOVE MEDIAN SURFACE OR AS DIRECTED BY THE ENGINEER. POST FOR ADVANCED STREET NAME SIGNS SHALL BE SQ. PERFORATED STEEL TUBING.
6. SIZING OF R1("STOP")SIGNS: 24"-LOCAL TO LOCAL INTERSECTION WITH LOW APPROACH SPEED AND GOOD VISIBILITY. 30"-STANDARD SIZE. 36"-WHERE THE APPROACH WIDTH IS GREATER THAN 30'. DUAL SIGNS SHALL BE USED WHERE IS A RAISED MEDIAN AND APPROACH WIDTH IS GREATER THAN 30'. 48"-WHERE THE ENGINEER DETERMINES THERE IS DEMONSTRATED OR POTENTIAL ACCIDENT PROBLEM.

PROJECT NO. 13-20-01-026
 SHEET NO. 09-250-01-1
 DATE: 07-16-02

APPROVED BY:

W.E. CAMERON, CITY ENGINEER

23764
 R.C.E. NO.

7-16-02
 DATE



City of San Clemente

Public Works Department - Engineering Division

MARK	REVISIONS	APPR.	DATE

Traffic Sign Locations

STD.NO.

 ST-18

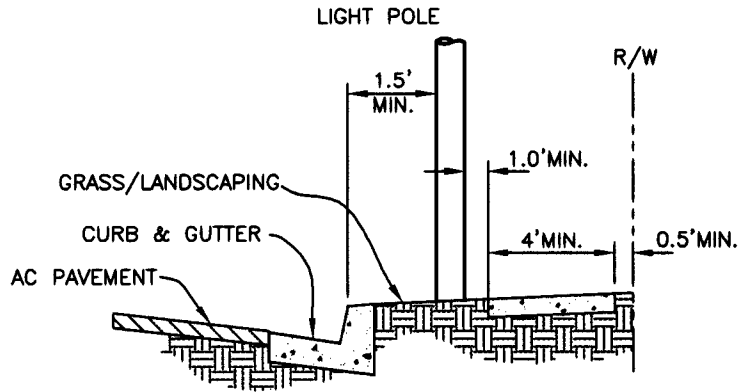

LEGEND FOR STREET LIGHT PLANS

- INDICATES 5800 LUMEN HPSV STREET LIGHT (70 WATT) 25 FT. LUMINAIRE HEIGHT.
- INDICATES FUTURE 5800 LUMEN HPSV STREET LIGHT (70 WATT) 25 FT. LUMINAIRE HEIGHT.
- ◇ INDICATES 9500 LUMEN HPSV STREET LIGHT (100 WATT) 25 FT. LUMINAIRE HEIGHT.
- ◐ INDICATES FUTURE 9500 LUMEN HPSV STREET LIGHT (100 WATT) 25 FT. LUMINAIRE HEIGHT.
- △ INDICATES 16000 LUMEN HPSV STREET LIGHT (150 WATT) 30 FT. LUMINAIRE HEIGHT.
- ▲ INDICATES FUTURE 16000 LUMEN HPSV STREET LIGHT (150 WATT) 30 FT. LUMINAIRE HEIGHT.
- INDICATES 22000 LUMEN HPSV STREET LIGHT (200 WATT) 30 FT. LUMINAIRE HEIGHT.
- ◼ INDICATES FUTURE STREET LIGHT LOCATION (22000 LUMEN HPSV; 200 WATT)
- ◐ INDICATES 30000 LUMEN HPSV STREET LIGHT (250 WATT) MOUNTED ON TRAFFIC SIGNAL POLE.

**LANDSCAPING ADJACENT TO CURB
INSTALL 8 FT. MAST ARM
CASE 1**

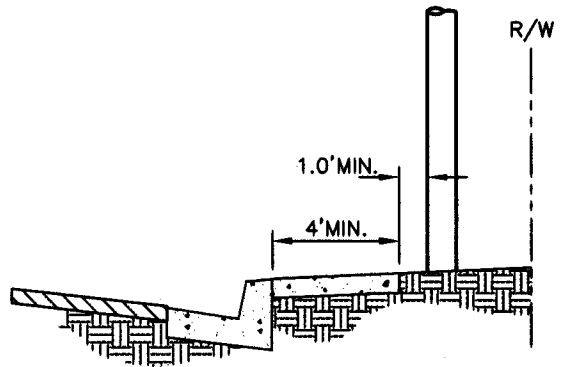

**SIDEWALK ADJACENT TO CURB
INSTALL 8 FT. MAST ARM
CASE 2**

D:\standards\ST_Std.dwg ST-19.dwg 06/24/2002 04:23:48 PM PDT

APPROVED BY: W.E. Cameron
 W.E. CAMERON, CITY ENGINEER 23764 7-16-02
 R.C.E. NO. DATE



City of San Clemente
 Public Works Department - Engineering Division

MARK	REVISIONS	APPR.	DATE

Street Light Standards

STD.NO.
ST-19
 SHEET 1 OF 5

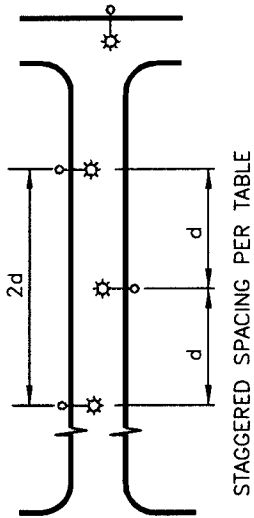

STREET CLASSIFICATION						
INDUSTRIAL	INDUSTRIAL COLLECTOR	SHORT LOCAL (<600 FEET)	LOCAL	COLLECTOR	SECONDARY HIGHWAY	PRIMARY HIGHWAY
200 FT.				100 FT. - 150 FT. 100 FT. MAXIMUM FOR COMMERCIAL ZONES		
CASE 1 IN PARKWAY FOR PARKWAY SIDEWALK. CASE 2 BEHIND SIDEWALK FOR CURB ADJACENT SIDEWALK.						
SPACING (d)						
PREFERRED LOCATION						
LUMINAIRE						
28 FT.	28 FT.	22 FT.	22 FT.	28 FT.	30 FT.	30 FT.
LUMINAIRE MOUNTING HEIGHT						
9500 LUMENS HPSV 100 WATTS	9500 LUMENS HPSV 100 WATTS	5800 LUMENS HPSV 70 WATTS	5800 LUMENS HPSV 70 WATTS	9500 LUMENS HPSV 100 WATTS	16000 LUMENS HPSV 200 WATTS	22000 LUMENS HPSV 200 WATTS

APPROVED BY: W.E. Cameron
 W.E. CAMERON, CITY ENGINEER
 23764 R.C.E. NO. DATE 7-16-02



City of San Clemente
 Public Works Department - Engineering Division

MARK	REVISIONS	APPR.	DATE

Street Light Standards

STD.NO.
ST-19
 SHEET 2 OF 5

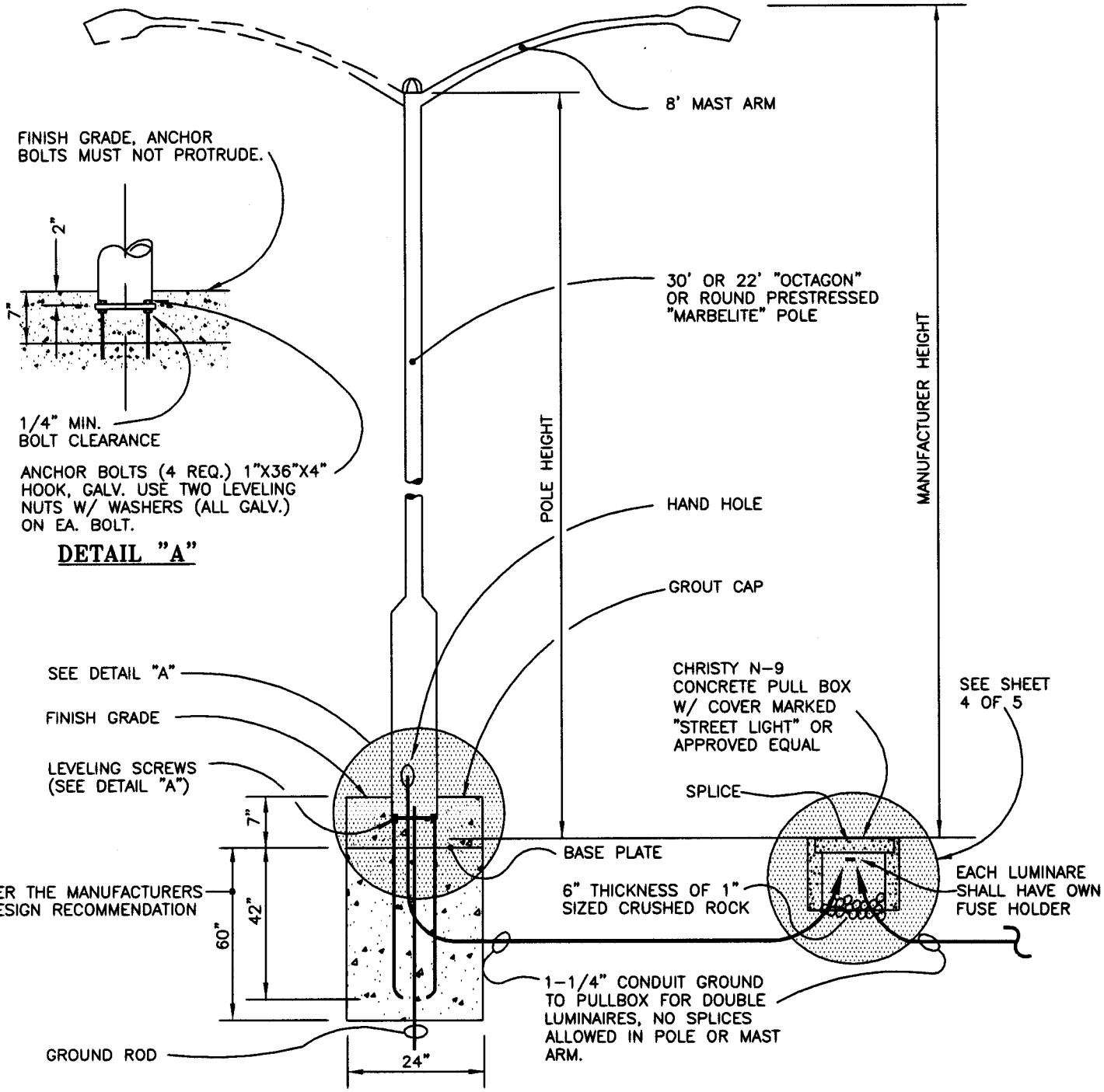

LIGHTING STANDARD DETAILS

D:\standards\ST_Stand\stdg\ST-19.dwg 06/24/2002 04:23:48 PM PDT

APPROVED BY:

 W.E. CAMERON, CITY ENGINEER 23764 7-16-02
 R.C.E. NO. DATE



City of San Clemente
 Public Works Department - Engineering Division

MARK	REVISIONS	APPR.	DATE

Street Light Standards

STD.NO.
ST-19
 SHEET 3 OF 5

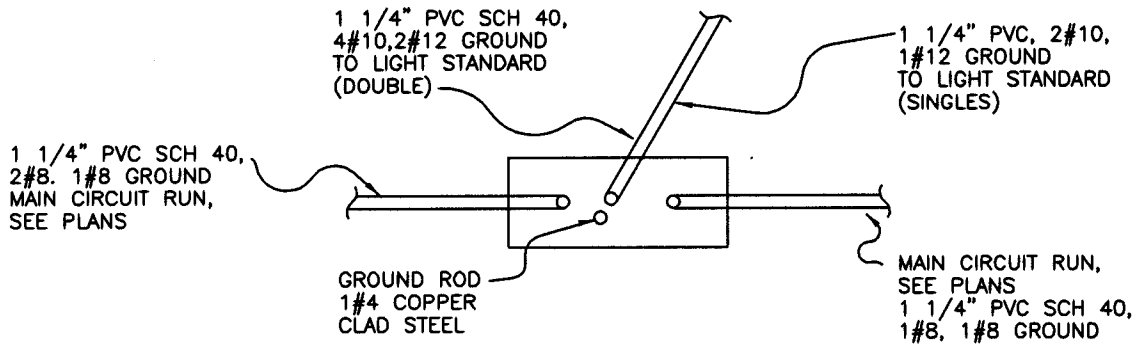

TYPICAL PULLBOX DETAIL

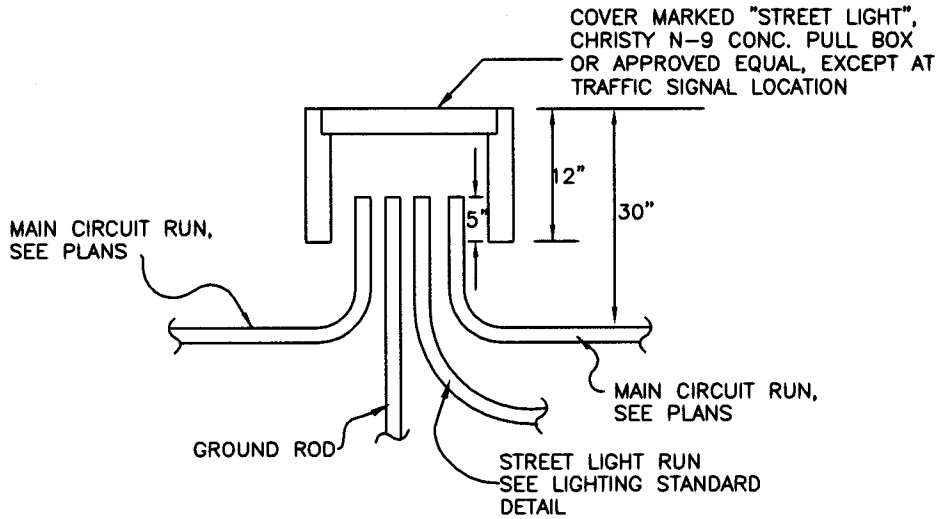

ALL PULLBOXES AT STREET LIGHT POLE BASE WILL BE SUPPLIED WITH HEP DUST DOUBLE IN-LINE 10 AMP. FUSE.

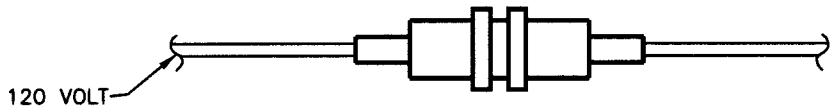

SINGLE FUSE HOLDER

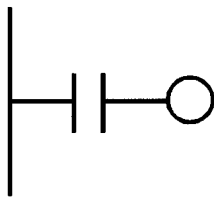

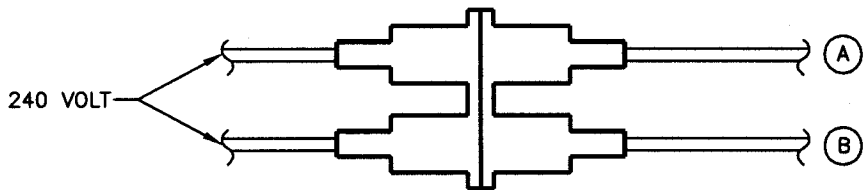

TYPICAL FUSE DIAGRAM



DOUBLE FUSE HOLDER



D:\standards\ST Standards\ST-19.dwg 06/24/2002 04:23:48 PM PDT

APPROVED BY:  W.E. CAMERON, CITY ENGINEER				23764 R.C.E. NO.		7-16-02 DATE		 City of San Clemente Public Works Department - Engineering Division	
				Street Light Standards				STD.NO. ST-19	
MARK REVISIONS APPR. DATE									

NOTES:

1. ORNAMENTAL STREET LIGHT POLES SHALL BE MARBLELITE OR APPROVED EQUAL.
2. ORNAMENTAL STREET LIGHTS SHALL BE INSTALLED AND DEDICATED TO THE CITY OF SAN CLEMENTE ON ALL DEDICATED CITY STREETS.
3. THE LUMINAIRES SHALL CONSIST OF COBRA HEAD AND DROP LENS ON A 8 FT MAST ARM. EXCEPT FOR TRAFFIC SIGNAL, LENS SHALL BE CUTOFF TYPE. 15 FT MAST ARM REQUIRED FOR STREET LIGHTS ON TRAFFIC SIGNAL POLE INSTALLATIONS.
4. ALL LUMINAIRES SHALL BE HIGH POWER FACTOR (HPF).
5. ALL LUMINAIRES P.E.C.'S (PHOTO CELLS) SHALL FACE NORTH.
6. ALL CONDUIT RUNS SHALL INCLUDE A TRACER WIRE.
7. SIDEWALK WIDTHS PER APPROVED STREET IMPROVEMENT PLANS. A MINIMUM OF 4 FEET UNOBSTRUCTED SIDEWALK CLEARANCE REQUIRED BEHIND STREET LIGHT POLE.
8. SAFETY LIGHTING SHALL BE PROVIDED IN ACCORDANCE WITH THESE STANDARDS AT INTERSECTION AND ALL OTHER LOCATIONS WHERE ILLUMINATION IS JUSTIFIED BY THE NEED FOR SIGHT DISTANCE, AS DETERMINED BY THE CITY ENGINEER.
9. ALL LIGHTING CIRCUITS SHALL INSTALLED UNDERGROUND.
10. TRANSFORMERS AND STANDARDS SHALL BE PROPERLY GROUNDED.
11. FUSE HOLDERS SHALL BE RUBBER TAPED, THEN VINYL TAPED ON LINE SIDE AND LOAD SIDE. DO NOT SCOTCH COAT FUSE HOLDERS.
12. HEIGHT FOR ALL COBRA HEADS LUMINAIRES SHALL BE 22' MINIMUM AND 30' MAXIMUM. MINIMUM LAMP SIZE AND TYPE SHALL BE 5,800 LUMEN HIGH PRESSURE SODIUM VAPOR.
13. LIGHTING LAYOUT SHALL COMMENCE AT STREET INTERSECTIONS, STREET LIGHT SPACING BETWEEN INTERSECTIONS SHALL BE SPECIFIED PER TABLE ON SHEET 2 AND LOCATED AT THE PROLONGATION OF PROPERTY LINES. STREET LIGHT LAYOUTS SHALL BE REVIEWED FOR CONFLICTS WITH OTHER UTILITIES, (CATCH BASINS, FIRE HYDRANTS, TRANSFORMERS, MAIL BOXES, ETC.).
14. STREET LIGHTS SHALL BE PLACED AT THE END OF ALL CUL-DE-SAC BULBS.
15. ALL STREET LAYOUTS AND LIGHTING DESIGNS SHALL BE APPROVED BY THE CITY ENGINEER.

J:\standards\ST_Standards\ST-19.dwg 06/24/2002 04:23:48 PM PDT

APPROVED BY:  W.E. CAMERON, CITY ENGINEER				23764 7-16-02 R.C.E. NO. DATE		 City of San Clemente Public Works Department - Engineering Division	
				Street Light Standards		STD.NO. ST-19	
MARK	REVISIONS	APPR.	DATE	SHEET 5 OF 5			

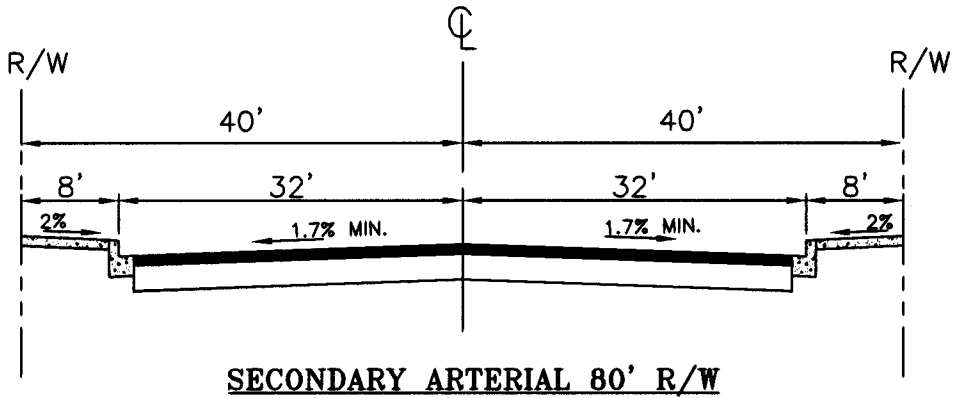
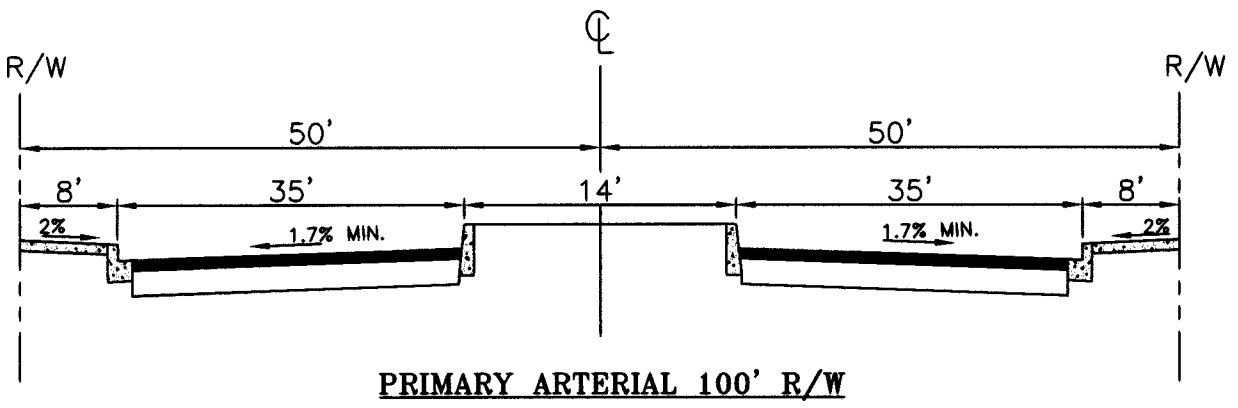
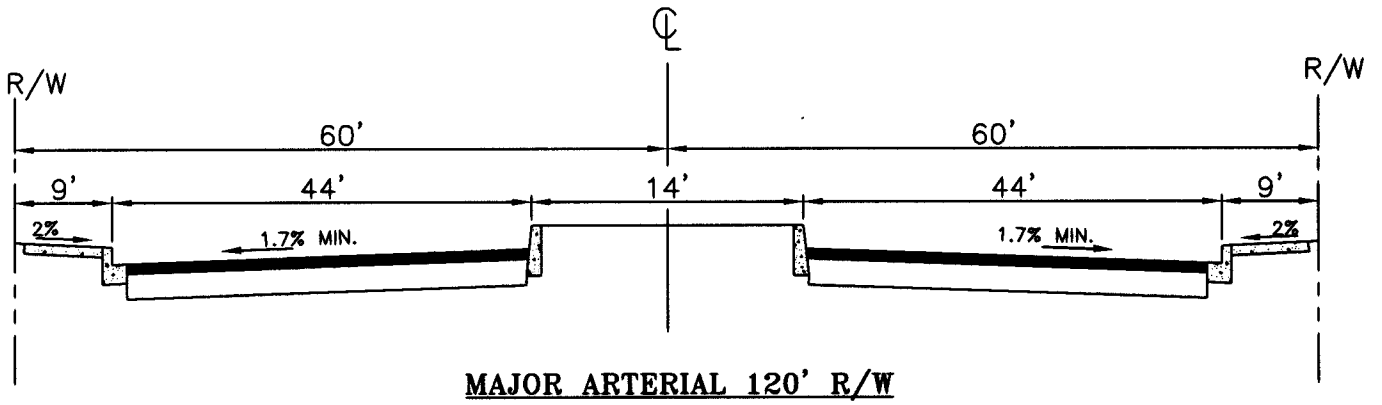

D:\standards\ST Stds.dwg ST-20.dwg 06/24/2002 04:41:39 PM PDT

APPROVED BY:

W.E. Cameron
W.E. CAMERON, CITY ENGINEER

23764
R.C.E. NO.

7-16-02
DATE



City of San Clemente
Public Works Department - Engineering Division

MARK	REVISIONS	APPR.	DATE

Standard Street Sections

STD.NO.

ST-20

SHEET 1 OF 2

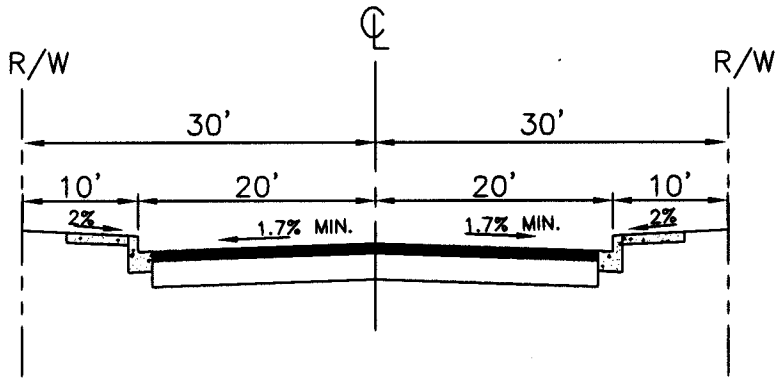

COLLECTOR STREET 60' R/W

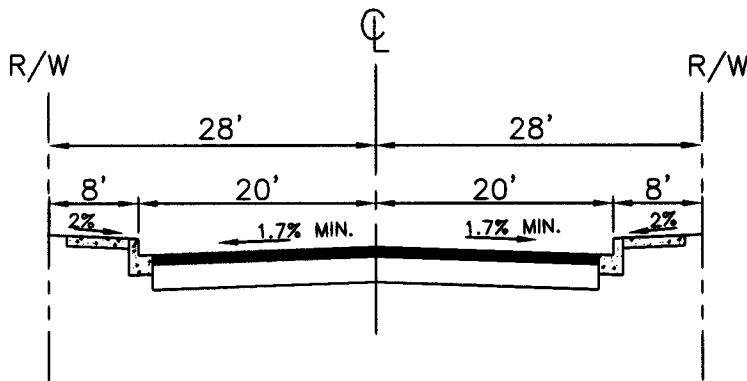

LOCAL STREET 56' R/W

NOTES:

1. PAVEMENT STRUCTURAL SECTION SHALL BE DETERMINED BY SOILS R-VALUE TEST AND TRAFFIC INDEX STUDY. MINIMUM SECTION IS 4" A.C. OVER 7" AGGREGATE BASE.
2. STREET SIDEWALKS SHALL BE INSTALLED ON BOTH SIDES OF ALL STREETS. MINIMUM SIDEWALK WIDTH FOR RESIDENTIAL IS FOUR (4) FEET, COMMERCIAL IS EIGHT (8) FEET.
3. SIDEWALKS, CURBS AND GUTTERS SHALL BE CONSTRUCTED PER CITY STANDARD PLANS, ST-3 AND ST-6.
4. STREET DESIGN SECTIONS FOR HILLSIDE AREAS, SINGLE SIDE ACCESS STREETS SHALL COMPLY WITH THE CITY OF SAN CLEMENTE MUNICIPAL CODE, SECTION 16.28.10.

D:\standards\ST Stds\dwg\ST-20.dwg 06/24/2002 04:41:39 PM PDT

APPROVED BY:

W.E. Cameron
W.E. CAMERON, CITY ENGINEER

23764 7-16-02
R.C.E. NO. DATE



City of San Clemente
Public Works Department - Engineering Division

MARK	REVISIONS	APPR.	DATE

Standard Street Sections

STD.NO.
ST-20
SHEET 2 OF 2

TYPICAL CONTINENTAL CROSSWALK MARKINGS

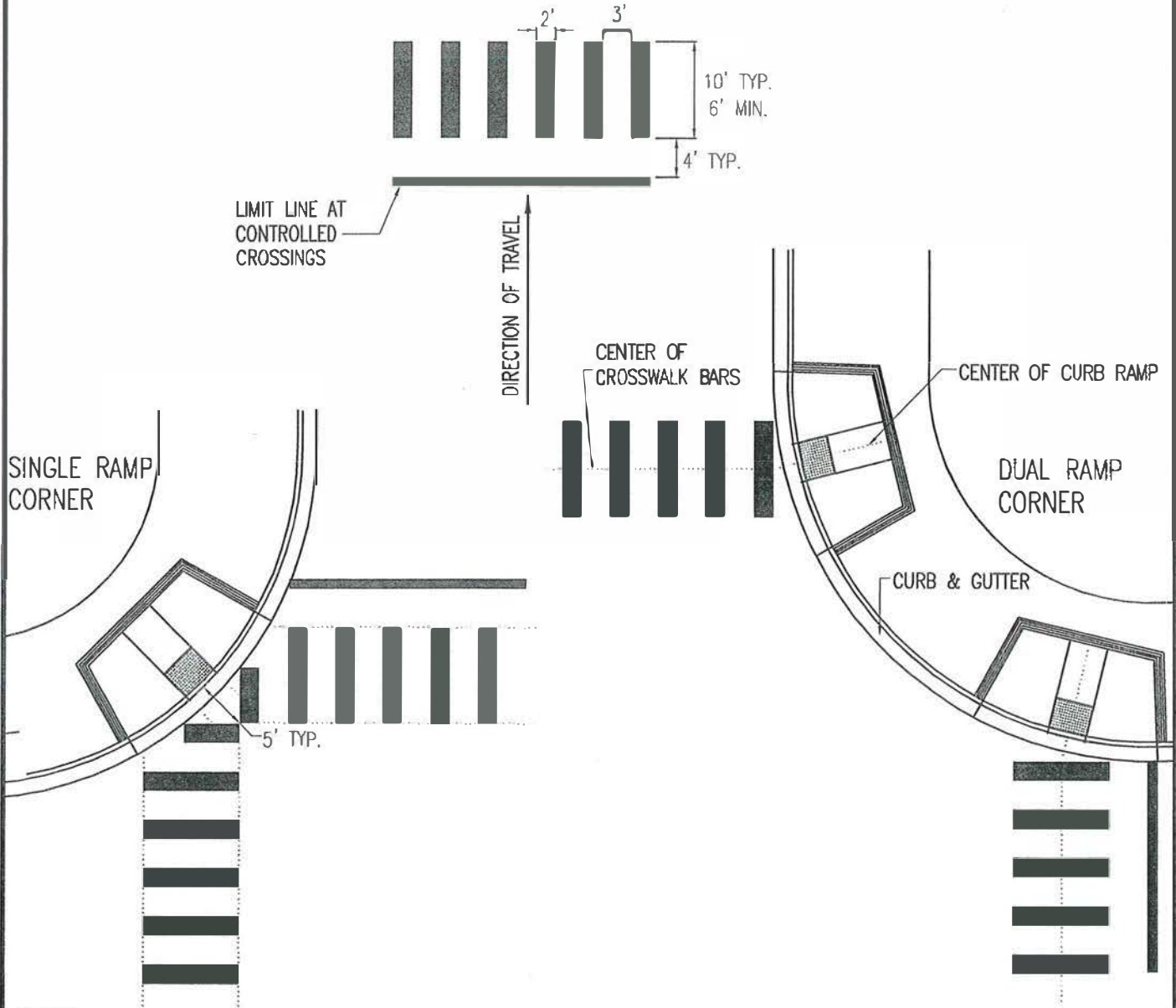

NOTES:

1. MARKED CROSSWALK LOCATIONS CONSISTING OF BRICK PAVERS OR OTHER DECORATIVE PAVING SHALL ONLY BE USED IN CONJUNCTION WITH TRANSVERSE CROSSWALK MARKINGS.
2. CONTINENTAL CROSSWALK MARKINGS SHALL BE ALIGNED PARALLEL TO THE DIRECTION OF VEHICULAR TRAVEL.
3. PARTIAL LENGTH BARS MAY BE USED WHERE FULL LENGTH BARS CAN NOT BE ACCOMMODATED, E.G. IN CURB RAMP RETURN VICINITY. HOWEVER, PARTIAL BARS SHALL MAINTAIN FULL WIDTH (2 FT).
4. CROSSWALK MARKINGS SHALL BE CALIFORNIA MANUAL ON UNIFORM TRAFFIC CONTROL DEVICES (CA-MUTCD) RETROREFLECTIVITY COMPLIANT AND SKID RESISTANT.

APPROVED BY:

Tom Bonigut
TOM BONIGUT, P.E.
 PW DIRECTOR/CITY ENGINEER

53961 12/18/19
 R.C.E. NO. DATE



City of San Clemente
 Public Works Department - Engineering Division

STD.NO.
ST-21

Continental Crosswalk

MARK	REVISIONS	APPR.	DATE

g:\graphics_cc\outocad engr drawings\standards\standard provisions & dwgs\technical std\2015\st-21 continental crosswalk.dwg 12.16.2019

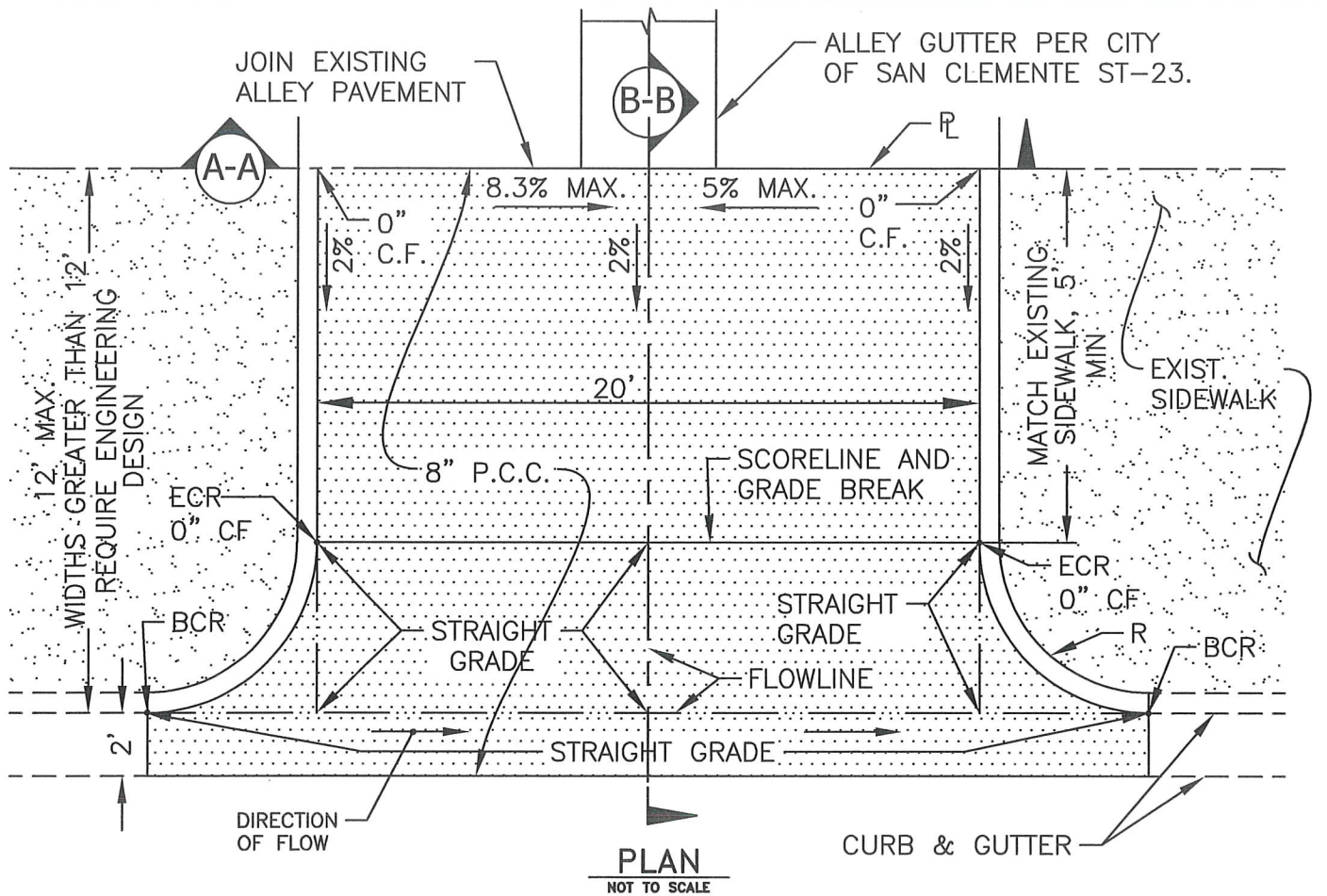

NOTES:

1. CURB RETURN RADIUS, R, SHALL BE 5' TYPICAL, UNLESS OTHERWISE SPECIFIED.
2. TOP OF CURB ELEVATIONS SHALL MATCH EXISTING SIDEWALK ELEVATIONS.
3. ALLEY INTERSECTION WITH A SLOPE EXCEEDING 16.66% SLOPE SHALL REQUIRE A SPECIAL PERMIT FROM THE TRANSPORTATION/ENGINEERING OFFICIAL
4. ACTUAL SHAPE AND LOCATION OF ALLEY INTERSECTION SHALL BE DETERMINED IN THE FIELD BY THE CITY ENGINEER.
5. ALLEY INTERSECTION AND NEW SIDEWALK WITHIN ALLEY INTERSECTION SHALL BE CLASS 560-C-3250, TYPE V CEMENT, 8" THICK MONOLITHIC P.C.C. OVER 6" CRUSHED MISCELLANEOUS BASE AT 95% RELATIVE COMPACTION.
6. ALL WORK SHALL BE CONSTRUCTED IN ACCORDANCE WITH THE CURRENT EDITION OF STANDARD SPECIFICATIONS FOR PUBLIC WORKS CONSTRUCTION (GREENBOOK).
7. CONTRACTOR SHALL HAVE A VALID CLASS "A" OR "C8" CALIFORNIA CONTRACTOR'S LICENSE.

APPROVED BY: *Thomas A. Bonigut*
THOMAS A. BONIGUT
 P.W. DIRECTOR/CITY ENGINEER

53961 2/17/21
 R.C.E. NO. DATE



City of San Clemente
 Public Works Department - Engineering Division

MARK	REVISIONS	APPR.	DATE

Alley Intersection Detail

STD.NO.
ST-22
 Sheet 1 of 2

W	8'	10'	15'	20'	25'	30'
d1,MAX	4"	5"	7.5"	10"	2.5"	15"
d2,MAX	2"	3"	3"	3"	3"	3"

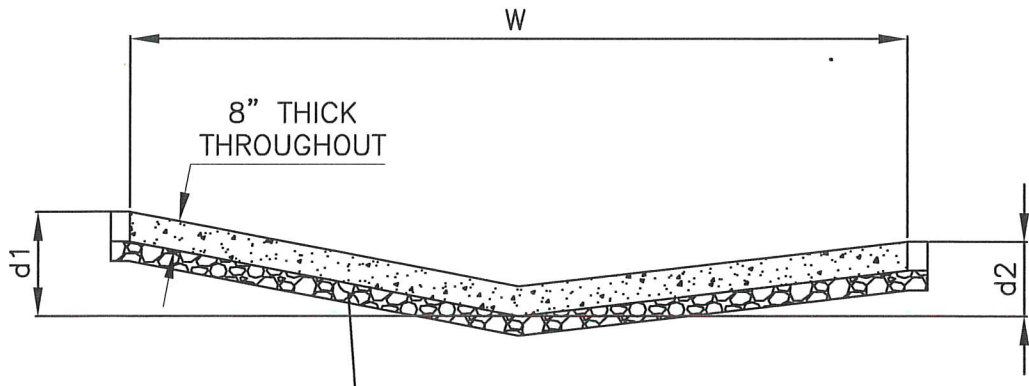

6" CRUSHED MISCELLANEOUS BASE,
95% RELATIVE COMPACTION (THROUGHOUT)

SECTION A-A
NOT TO SCALE

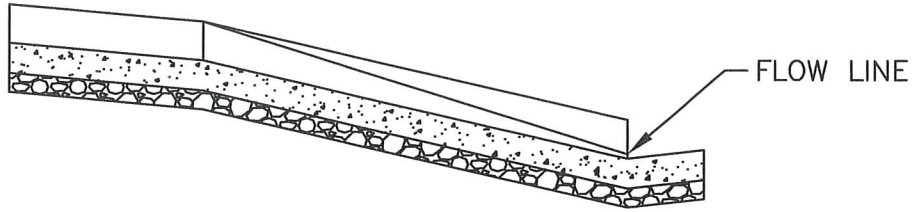

SECTION B-B
NOT TO SCALE

APPROVED BY: *Thomas A. Bonigut*
THOMAS A. BONIGUT
 P.W. DIRECTOR/CITY ENGINEER

53961 *7/21/21*
 R.C.E. NO. DATE



City of San Clemente
 Public Works Department - Engineering Division

MARK	REVISIONS	APPR.	DATE

Alley Intersection Detail

STD.NO.
ST-22
 Sheet 2 of 2

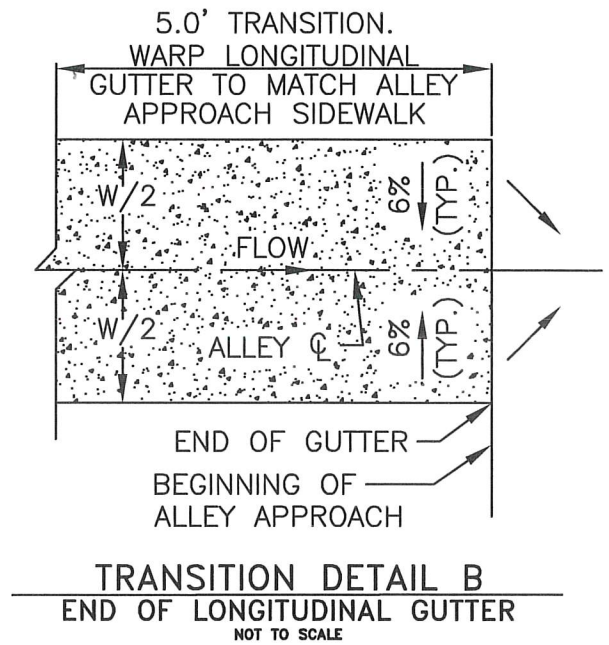
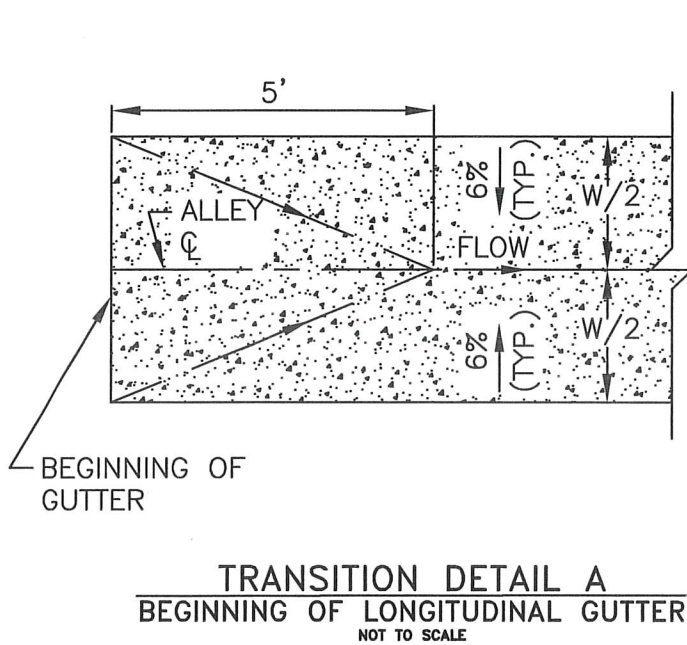
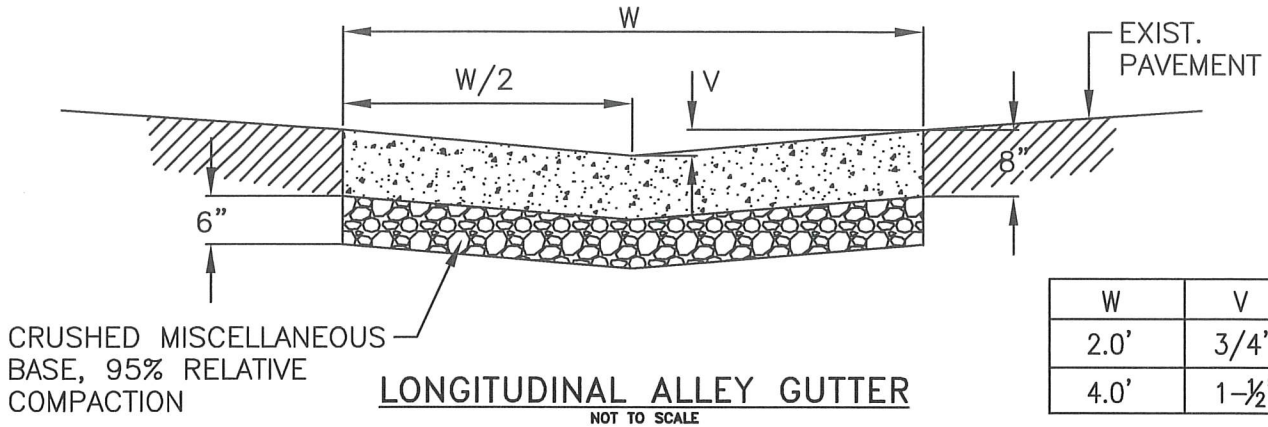

NOTES:

1. LONGITUDINAL ALLEY SHALL BE CONCRETE CLASS 560-C-3250, TYPE V CEMENT.
2. CONTROL JOINTS SHALL BE PLACED AT 10' INTERVALS FOR FULL LENGTH OF LONGITUDINAL GUTTER..
3. ALL WORK SHALL BE CONSTRUCTED IN ACCORDANCE WITH THE CURRENT EDITION OF STANDARD SPECIFICATIONS FOR PUBLIC WORKS CONSTRUCTION (GREENBOOK).
4. CONTRACTOR SHALL HAVE A VALID CLASS "A" OR "C8" CALIFORNIA CONTRACTOR'S LICENSE.

APPROVED BY:

Thomas A. Bonigut
THOMAS A. BONIGUT
P.W. DIRECTOR/CITY ENGINEER

53961
R.C.E. NO. DATE



City of San Clemente
Public Works Department - Engineering Division

MARK	REVISIONS	APPR.	DATE

Longitudinal Alley Gutter Detail

STD.NO.
ST-23

CASE 1
(2'-0" LONGITUDINAL GUTTER)

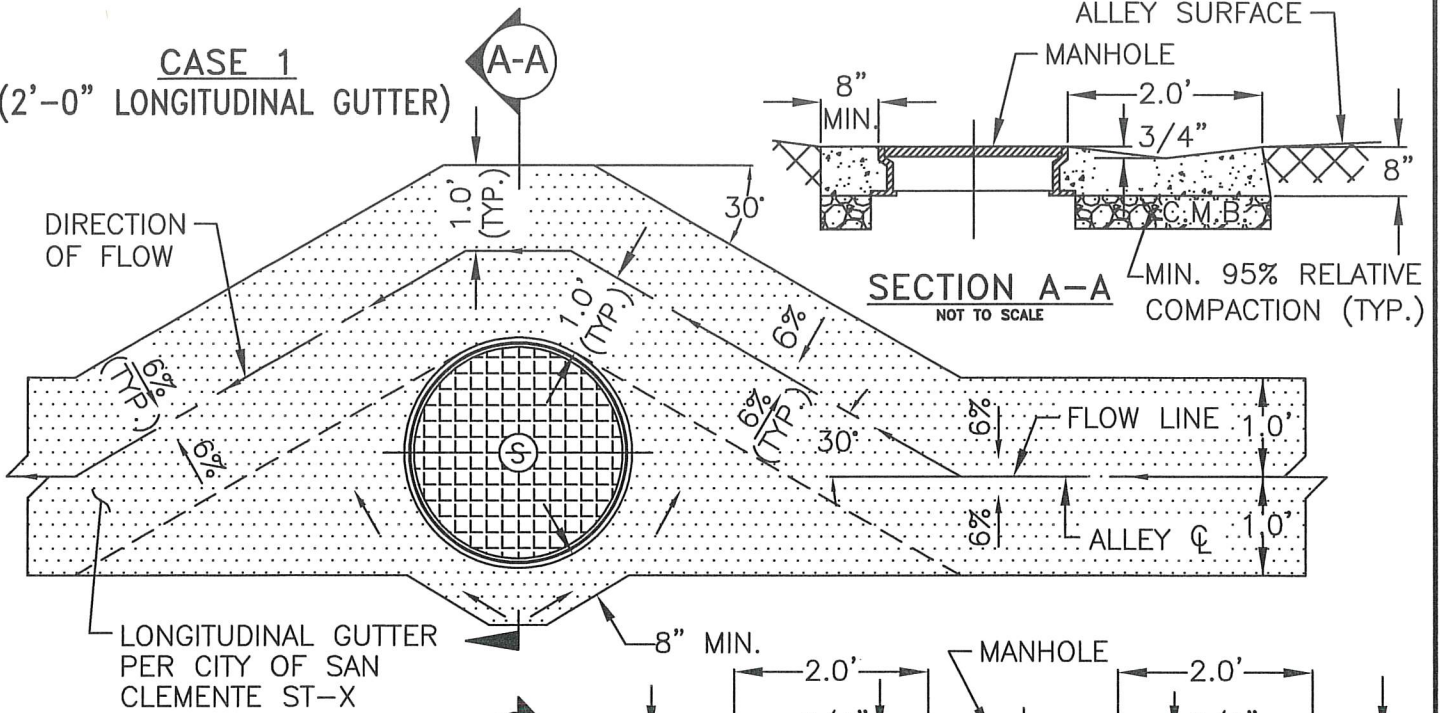

CASE 2
(4'-0" LONGITUDINAL GUTTER)

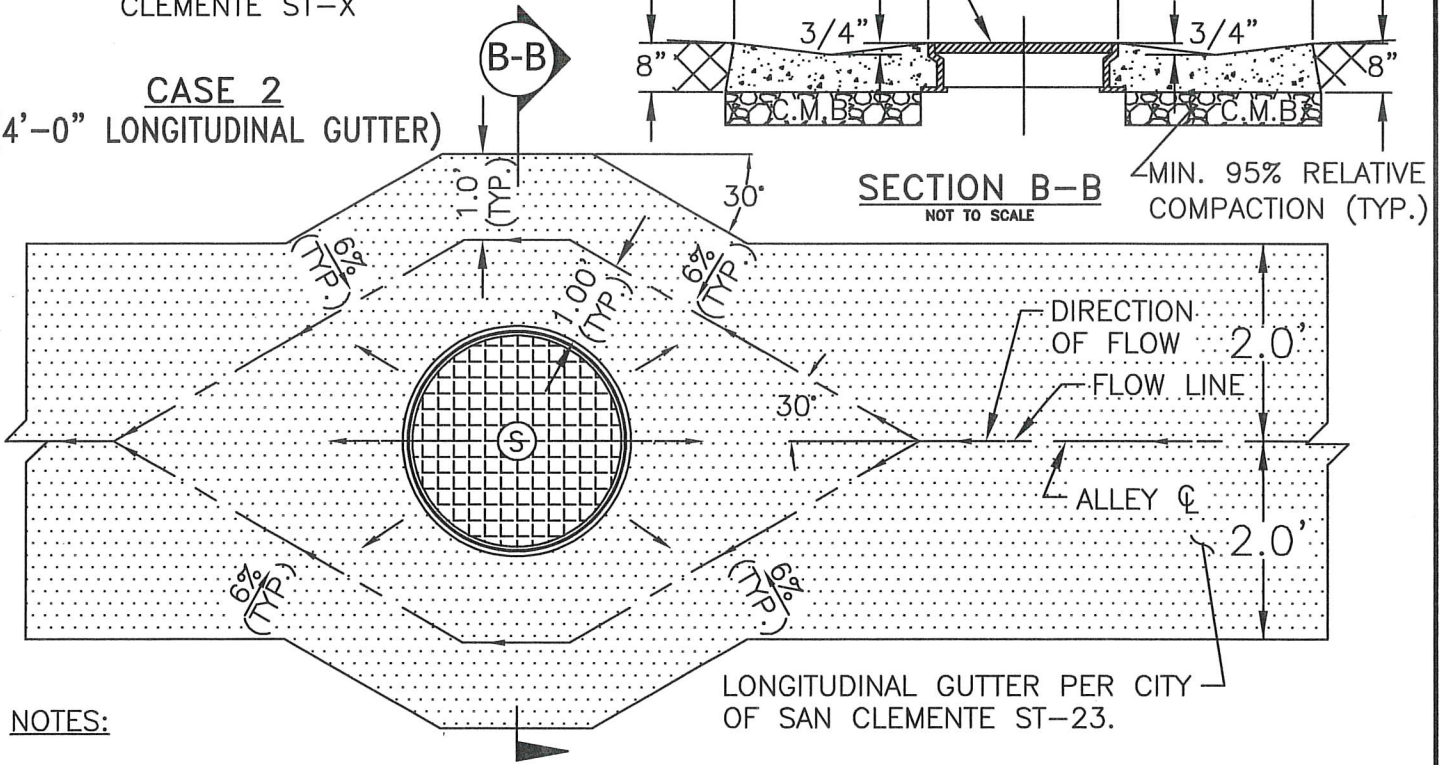

NOTES:

1. LONGITUDINAL ALLEY GUTTER SHALL BE CONCRETE CLASS 560-C-3250, TYPE V CEMENT.
2. ALL WORK SHALL BE CONSTRUCTED IN ACCORDANCE WITH THE CURRENT STANDARD SPECIFICATIONS FOR PUBLIC WORKS CONSTRUCTION.
3. CONTRACTOR SHALL HAVE A VALID CLASS "A" OR "C8" CALIFORNIA CONTRACTOR'S LICENSE.

APPROVED BY:

Thomas A. Bonigut

THOMAS A. BONIGUT
P.W. DIRECTOR/CITY ENGINEER

53961 2/17/21
R.C.E. NO. DATE



City of San Clemente
Public Works Department - Engineering Division

MARK	REVISIONS	APPR.	DATE

Longitudinal Alley Gutter at Manhole	STD.NO.
	ST-24
	Sheet 1 of 2

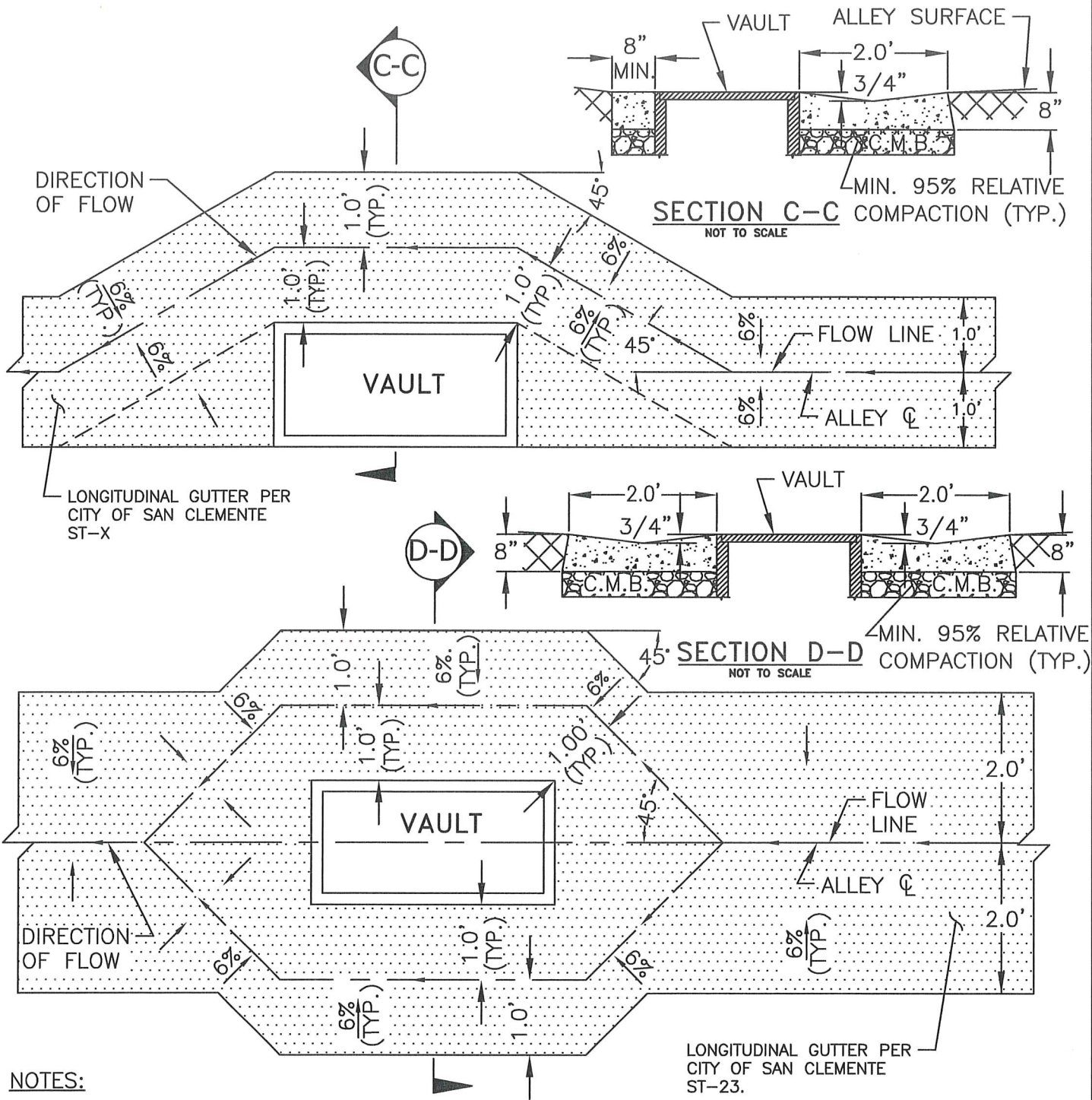

NOTES:

1. LONGITUDINAL ALLEY GUTTER SHALL BE CONCRETE CLASS 560-C-3250, TYPE V CEMENT.
2. ALL WORK SHALL BE CONSTRUCTED IN ACCORDANCE WITH THE CURRENT STANDARD SPECIFICATIONS FOR PUBLIC WORKS CONSTRUCTION.
3. CONTRACTOR SHALL HAVE A VALID CLASS "A" OR "C8" CALIFORNIA CONTRACTOR'S LICENSE.

APPROVED BY:

 THOMAS A. BONIGUT
 P.W. DIRECTOR/CITY ENGINEER

53961 2/17/21
 R.C.E. NO. DATE



City of San Clemente
 Public Works Department - Engineering Division

MARK	REVISIONS	APPR.	DATE

Longitudinal Alley Gutter
 at Vault

STD.NO.
 ST-24
 Sheet 2 of 2

STANDARD GENERAL NOTES

**CITY OF SAN CLEMENTE
GENERAL NOTES
FOR
EROSION CONTROL**

1. **IN CASE OF EMERGENCY CALL:** _____ **WORK TELEPHONE NO.:** _____
 NAME **HOME TELEPHONE NO.:** _____
2. **EQUIPMENT AND WORKERS FOR EMERGENCY WORK SHALL BE MADE AVAILABLE AT ALL TIMES DURING THE RAINY SEASON. NECESSARY MATERIALS SHALL BE AVAILABLE ON SITE AND STOCKPILED AT CONVENIENT LOCATIONS TO FACILITATE RAPID CONSTRUCTION OF TEMPORARY DEVICES WHEN RAIN IS IMMINENT.**
3. **EROSION CONTROL DEVICES SHALL NOT BE MOVED OR MODIFIED WITHOUT THE APPROVAL OF THE BUILDING OFFICIAL OR CITY ENGINEER.**
4. **ALL REMOVABLE EROSION PROTECTIVE DEVICES SHALL BE IN PLACE AT THE END OF EACH WORKING DAY WHEN THE 5-DAY RAIN PROBABILITY FORECAST EXCEEDS 40%.**
5. **AFTER A RAINSTORM ALL SILT AND DEBRIS SHALL BE REMOVED FROM STREETS. CHECK BERMS AND BASINS.**
6. **GRADED AREAS ON THE PERMITTED AREA PERIMETER MUST DRAIN AWAY FROM THE FACE OF SLOPES AT THE CONCLUSION OF EACH WORKING DAY. DRAINAGE TO BE DIRECTED TOWARD DESILTING FACILITIES.**
7. **THE PERMITTEE SHALL BE RESPONSIBLE AND SHALL TAKE NECESSARY PRECAUTIONS TO PREVENT PUBLIC TRESPASS ONTO AREAS WHERE IMPOUNDED WATER CREATES A HAZARDOUS CONDITION.**
8. **ALL TEMPORARY GRADING HAUL ROADS WITHIN AREAS WHICH ARE TO REMAIN UNDEVELOPED AND NATURAL SHALL BE RESTORED TO NATURAL CONDITIONS AND REVEGETATED WITH NATIVE GRASSES UPON COMPLETION OF GRADING OPERATIONS.**
9. **ALL CONSTRUCTION VEHICLES OR EQUIPMENT, FIXED OR MOBILE OPERATED WITHIN 1000' OF A DWELLING SHALL BE EQUIPPED WITH PROPERLY OPERATING AND MAINTAINED MUFFLERS.**
10. **ALL OPERATIONS SHALL COMPLY WITH ORANGE COUNTY CODIFIED ORDINANCE DIVISION 6 (NOISE CONTROL).**
11. **STOCKPILING AND/OR VEHICLE STAGING AREAS SHALL BE LOCATED AS FAR AS PRACTICABLE FROM DWELLINGS.**
12. **EROSION CONTROL DEVICES WILL BE MODIFIED AS NEEDED AS THE PROJECT PROGRESSES, AND PLANS OF THESE CHANGES SUBMITTED FOR PLAN CHECK AS REQUIRED.**
13. **THE PLACEMENT OF ADDITIONAL DEVICES TO REDUCE EROSION DAMAGE WITHIN THE SITE IS LEFT TO THE DISCRETION OF THE FIELD ENGINEER.**
14. **THE DESIGNED CIVIL ENGINEER WILL OBSERVE EROSION CONTROL WORK AND WILL INFORM THE CITY AND THE DEVELOPER IF THE WORK IS NOT IN ACCORDANCE WITH THE APPROVED PLAN.**

**CITY OF SAN CLEMENTE
GENERAL NOTES
FOR
GRADING PLANS**

1. ALL WORK SHALL BE IN ACCORDANCE WITH THE GRADING ORDINANCE AND MANUAL OF THE CITY OF SAN CLEMENTE AND ANY SPECIAL REQUIREMENTS OF THE PERMIT.
2. NO GRADING SHALL BE STARTED WITHOUT FIRST NOTIFYING THE CITY ENGINEER. A PRE-GRADE MEETING IS REQUIRED BEFORE START OF GRADING WITH THE FOLLOWING PEOPLE PRESENT: OWNER, GRADING CONTRACTORS, DESIGN CIVIL ENGINEER, SOILS ENGINEER, GEOLOGIST, CITY GRADING INSPECTOR OR THEIR REPRESENTATIVES, AND WHEN REQUIRED, THE ARCHAEOLOGIST, PALEONTOLOGIST AND/OR OTHER UTILITY REPRESENTATIVES.
3. THE PERMITTEE OR HIS AGENT SHALL NOTIFY THE ENGINEERING DIVISION WHEN THE GRADING OPERATION IS READY FOR EACH OF THE FOLLOWING INSPECTIONS.
 - A. INITIAL INSPECTION: WHEN THE PERMITTEE IS READY TO BEGIN WORK, BUT NOT LESS THAN TWO DAYS BEFORE ANY GRADING OR BRUSHING IS STARTED.
 - B. TOE INSPECTION: AFTER THE NATURAL GROUND OR BEDROCK IS EXPOSED AND PREPARED TO RECEIVE FILL, BUT NOT BEFORE THE FILL IS PLACED.
 - C. EXCAVATION INSPECTION: AFTER THE EXCAVATION IS STARTED, BUT BEFORE THE VERTICAL DEPTH OF THE EXCAVATION EXCEEDS TEN FEET.
 - D. FILL INSPECTION: AFTER THE FILL PLACEMENTS STARTED, BUT BEFORE THE VERTICAL HEIGHT OF THE FILL EXCEEDS TEN FEET.
 - E. DRAINAGE DEVICE INSPECTION: AFTER FORMING OF TERRACE DRAINS, DOWNDRAINS, OR AFTER PLACEMENT OF PIPE IN SUBDRAINS, BUT BEFORE ANY CONCRETE OR FILTER MATERIAL IS PLACED.
 - F. ROUGH GRADING: WHEN ALL ROUGH GRADING HAS BEEN COMPLETED. THIS INSPECTION MAY BE CALLED FOR AT THE COMPLETION OF ROUGH GRADING.
 - G. FINAL: WHEN ALL WORK INCLUDING INSTALLATION OF ALL DRAINAGE STRUCTURES AND OTHER PROTECTIVE DEVICES HAS BEEN COMPLETED AND THE AS-GRADED PLAN, PROFESSIONAL CERTIFICATIONS AND THE REQUIRED REPORTS HAVE BEEN SUBMITTED.
4. CUT SLOPES SHALL BE NO STEEPER THAN 2 HORIZONTAL TO 1 VERTICAL.
5. FILL SLOPES SHALL BE NO STEEPER THAN 2 HORIZONTAL TO 1 VERTICAL AND SHALL HAVE NOT LESS THAN 90% COMPACTION OUT TO THE FINISHED SURFACE.
6. FILLS SHALL BE COMPACTED THROUGHOUT TO A MINIMUM OF 90% RELATIVE DENSITY. MAXIMUM DENSITY TO BE DETERMINED BY ASTM-D1557 (FIVE (5) LAYER TEST) OR APPROVED EQUIVALENT, AND FIELD DENSITY BY UNIFORM BUILDING CODE STANDARD NO. 70-2, OR APPROVED EQUIVALENT.
7. AREAS TO RECEIVE FILL SHALL BE PROPERLY PREPARED AND APPROVED BY THE SOILS ENGINEER AND/OR ENGINEERING GEOLOGIST PRIOR TO PLACING OF FILL.
8. FILLS SHALL BE BENCHED INTO COMPETENT MATERIAL AS PER DETAIL ON PLAN.

9. ALL EXISTING FILLS SHALL BE APPROVED BY THE SOILS ENGINEER OR REMOVED BEFORE ANY ADDITIONAL FILLS ARE ADDED.
10. THE EXISTING IRRIGATION LINES, SUBGRADE STRUCTURES, SEPTIC TANKS, AND CISTERNS SHALL BE REMOVED, OR CRUSHED IN PLACE AND BACKFILLED, AND APPROVED BY THE CITY INSPECTOR AND SOILS ENGINEER.
11. THE STOCKPILING OF EXCESS MATERIAL SHALL BE APPROVED BY THE CITY ENGINEER PRIOR TO EXCAVATION.
12. THE DESIGN CIVIL ENGINEER, PRIOR TO ROUGH GRADE APPROVAL, SHALL PROVIDE THE MINIMUM OF ONE BLUE TOP PER LOT, SET AT THE HIGHEST POINT IN THE FINISHED DRAINAGE SWALE.
13. ALL TRENCH BACKFILLS SHALL BE TESTED AND APPROVED BY THE SITE SOILS ENGINEER PER THE GRADING CODE.
14. THE ENGINEERING GEOLOGIST AND SOILS ENGINEER SHALL, AFTER CLEARING AND PRIOR TO THE PLACEMENT OF FILL IN CANYONS, OBSERVE AND REVIEW EACH CANYON FOR AREAS OF ADVERSE STABILITY AND TO DETERMINE THE PRESENCE OR ABSENCE OF SUBSURFACE WATER OR SPRING FLOW. IF NEEDED, DRAINS (IN ADDITION TO THOSE DEPICTED ON THIS PLAN) WILL BE DESIGNED AND CONSTRUCTED PRIOR TO THE PLACEMENT OF FILL IN EACH RESPECTIVE CANYON. ANY ADDITIONS SHALL BE NOTED ON THE "AS-BUILT" PLANS.
15. SUBDRAIN OUTLETS SHALL BE COMPLETED AT THE BEGINNING OF THE SUBDRAIN CONSTRUCTION.
16. THE EXACT LOCATION OF THE SUBDRAINS SHALL BE SURVEYED IN THE FIELD FOR LINE AND GRADE AND NOTED AND SHOWN ON THE "AS-BUILT" PLANS.
17. ALL CUT SLOPES SHALL BE INVESTIGATED BOTH DURING AND AFTER GRADING BY AN ENGINEERING GEOLOGIST TO EVALUATE THE STABILITY OF EACH SLOPE SHOULD EXCAVATION DISCLOSE ANY GEOLOGICAL HAZARDS OR POTENTIAL GEOLOGICAL HAZARDS, THE ENGINEERING GEOLOGIST SHALL RECOMMEND NECESSARY TREATMENT TO THE CITY ENGINEER FOR APPROVAL. ALL APPROVAL TO BE GRANTED ON THE BASIS OF DETAILED GEOLOGICAL MAPPING AND WRITTEN FIELD MEMO.
18. WHERE SUPPORT OR BUTTRESSING OF CUT AND NATURAL SLOPES IS DETERMINED TO BE NECESSARY BY THE ENGINEERING GEOLOGIST AND SOILS ENGINEER, THE SOILS ENGINEER WILL SUBMIT DESIGN, LOCATIONS AND CALCULATIONS TO THE CITY ENGINEER PRIOR TO CONSTRUCTION. THE ENGINEERING GEOLOGIST AND SOILS ENGINEER WILL OBSERVE THE CONSTRUCTION OF THE BUTTRESSING AND COMMENT ON THE STABILITY OF THE SLOPE AND ADJACENT STRUCTURES UPON COMPLETION. ALL CHANGES SHALL BE ADDRESSED IN THE FINAL SOILS REPORT.
19. WHEN CUT PADS ARE BROUGHT TO NEAR GRADE, THE ENGINEERING GEOLOGIST SHALL DETERMINE IF THE BEDROCK IS EXTENSIVELY FRACTURED OR FAULTED AND WILL READILY TRANSMIT WATER. IF CONSIDERED NECESSARY BY THE ENGINEERING GEOLOGIST AND SOILS ENGINEER, A COMPACTED FILL BLANKET WILL BE PLACED.
20. THE ENGINEERING GEOLOGIST OR HIS REPRESENTATIVE SHALL BE ON SITE FOR OBSERVATION AND TESTING, AS NECESSARY, AND SUBMIT A COMPLETE REPORT AND MAP UPON COMPLETION OF THE ROUGH GRADING.
21. THE FINAL COMPACTION REPORT AND APPROVAL FROM THE SOILS ENGINEER SHALL CONTAIN THE TYPE OF FIELD TESTING PERFORMED. EACH TEST SHALL BE IDENTIFIED WITH THE METHOD OF OBTAINING THE IN-PLACE DENSITY, WHETHER SAND CONE OR DRIVE RING, AND SHALL BE SO

NOTED FOR EACH TEST. SUFFICIENT MAXIMUM DENSITY DETERMINATIONS SHALL BE PERFORMED TO VERIFY THE ACCURACY OF THE MAXIMUM DENSITY CURVES USED BY THE FIELD TECHNICIAN.

22. THE SOILS ENGINEER AND ENGINEERING GEOLOGIST SHALL PROVIDE OBSERVATION AND TESTING, SERVICES, AS NECESSARY, AND BE AVAILABLE DURING GRADING TO VERIFY COMPLIANCE WITH THE PLANS, SPECIFICATIONS, AND CODE WITHIN THEIR PURVIEW.
23. THE DESIGN CIVIL ENGINEER SHALL EXERCISE SUFFICIENT CONTROL DURING GRADING AND CONSTRUCTION TO INSURE COMPLIANCE WITH THE PLANS, SPECIFICATIONS, AND CODE WITHIN HIS PURVIEW.
24. DUST SHALL BE CONTROLLED BY WATERING.
25. SANITARY FACILITIES SHALL BE MAINTAINED ON THE SITE.
26. THE LOCATION AND PROTECTION OF ALL UTILITIES ARE THE RESPONSIBILITY OF THE GRADING CONTRACTOR.
27. APPROVED PROTECTIVE MEASURES AND TEMPORARY DRAINAGE PROVISIONS MUST BE USED TO PROTECT ADJOINING PROPERTIES DURING THE GRADING PROJECT.
28. PRIOR TO FINAL APPROVAL, THE DESIGN CIVIL ENGINEER SHALL CERTIFY TO THE ENGINEERING DIVISION THE NUMBER OF YARDS TO CUT, FILL AND IMPORT MOVED DURING THE GRADING OPERATIONS.
29. ALL CONCRETE STRUCTURES THAT COME IN CONTACT WITH THE ON-SITE SOILS SHALL BE CONSTRUCTED WITH TYPE 5 CEMENT UNLESS OTHERWISE APPROVED BY THE CITY ENGINEER.
30. EXPORT SOIL MUST GO TO A LEGAL DUMP OR TO A PERMITTED SITE APPROVED BY THE CITY ENGINEER.
31. SLOPES EXCEEDING FIVE FEET IN HEIGHT MUST BE PLANTED WITH A PLANT MATERIAL DESIGNED BY A REGISTERED LANDSCAPE ARCHITECT AND APPROVED BY THE CITY AND MUST BE PROVIDED WITH AN APPROVED IRRIGATION SYSTEM.
32. PRIOR TO FINAL APPROVAL, THE GRADING CONTRACTOR SHALL SUBMIT A STATEMENT OF COMPLIANCE FOR THE APPROVED GRADING PLAN.
33. FOR GRADING PERMITS ISSUED BEFORE AUGUST 15, EROSION CONTROL PLANS, IF NECESSARY, SHALL BE REQUIRED AND SHALL BE SUBMITTED TO AND APPROVED BY THE CITY ENGINEER BY SEPTEMBER 15. FOR GRADING PERMITS WHICH ARE ISSUED AFTER AUGUST 15, AND WHERE GRADING IS NOT EXPECTED TO BE COMPLETED BY OCTOBER 15, EROSION CONTROL PROVISIONS SHALL BE REQUIRED.
34. THE APPROVED SOIL ENGINEERING REPORT PREPARED BY

ENTITLED

REPORT NO: _____

DATED: _____

AND ALL REVISIONS ARE TO BE CONSIDERED PART OF THE PLANS, AND THE RECOMMENDATIONS CONTAINED THEREIN ARE TO BE ADHERED TO.

35. CONCRETE FOR SIDEWALK, CURB & GUTTER, ACCESS RAMPS, AND DRIVE APPROACHES SHALL HAVE A MINIMUM ULTIMATE COMPRESSIVE STRENGTH AT 28 DAYS OF 3250 PSI. CONCRETE MAY BE PNEUMATICALLY PLACED AND SHALL CONFORM TO SECTION 201 OF THE STANDARD SPECIFICATIONS FOR PUBLIC WORKS CONSTRUCTION (GREENBOOK).

36. CONCRETE FOR EXTERIOR RETAINING WALLS AND STRUCTURAL FOUNDATIONS SHALL HAVE A MINIMUM ULTIMATE COMPRESSIVE STRENGTH AT 28 DAYS OF 4500 PSI WITH A WATER-CEMENT RATIO OF 0.45.
37. CONCRETE REINFORCING SHALL BE 6" X 6 - w 1.4 WELDED WIRE MESH (W.W.M.) OR APPROVED EQUAL.
38. GROUND SHALL BE PREWETTED TO THE SATISFACTION OF THE CITY INSPECTOR OR THE SOILS ENGINEER PRIOR TO PLACEMENT OF CONCRETE. MOISTURE LOSS RETARDANT SHALL BE USED WHEN REQUIRED BY THE SOILS ENGINEER.
39. FOR COMPACTED FILL:
 - A. A MINIMUM FOUNDATION BEARING VALUE OF 1500 P.S.F. IS REQUIRED UNLESS MODIFIED BY THE SOILS REPORT.
 - B. NUMBER OF TESTS TO BE MADE SHALL BE:
 - 1 TEST FOR EACH 2 FEET OF FILL OR
 - 1 TEST FOR EACH 1,000 CUBIC YARDS (WHICHEVER IS GREATER).
40. THE UNDERSIGNED CIVIL ENGINEERS WILL BE RESPONSIBLE FOR THE MINIMUM PROFESSIONAL INSPECTIONS IN ACCORDANCE WITH SUBARTICLE 14 OF THE CITY OF SAN CLEMENTE'S GRADING ORDINANCE & GRADING MANUAL.
41. DETRIMENTAL AMOUNTS OF ORGANIC MATERIAL SHALL NOT BE PERMITTED IN FILLS. EXCEPT AS OUTLINED BELOW, NO ROCK OR SIMILAR IRREDUCIBLE MATERIAL WITH A MAXIMUM DIMENSION GREATER THAN TWELVE (12) INCHES SHALL BE BURIED OR LACED IN FILLS.
 - A. THE SOILS ENGINEER MAY PERMIT PLACEMENT OF LARGER ROCK WHEN THE SOILS ENGINEER PROPERLY DEvised A METHOD OF PLACEMENT, CONTINUOUSLY INSPECTS PLACEMENT, AND APPROVES THE FILL STABILITY AND COMPETENCY. THE FOLLOWING CONDITIONS SHALL ALSO APPLY:
 - B. PRIOR TO ISSUANCE OF THE GRADING PERMIT, POTENTIAL ROCK DISPOSAL AREA(S) SHALL BE DELINEATED ON THE GRADING PLAN.
 - C. ROCK SIZES GREATER THAN TWELVE (12) INCHES IN MAXIMUM DIMENSION SHALL BE TEN (10) FEET OR MORE BELOW GRADE, MEASURED VERTICALLY. THIS DEPTH MAY BE REDUCED UPON RECOMMENDATION OF THE SOILS ENGINEER AND APPROVAL OF THE BUILDING OFFICIAL PROVIDING THAT THE PERMITTED USE OF THE PROPERTY WILL NOT BE IMPAIRED.
 - D. ROCKS GREATER THAN TWELVE (12) INCHES SHALL BE PLACED SO AS TO BE COMPLETELY SURROUNDED BY SOILS; NO NESTING OF ROCKS WILL BE PERMITTED.
 - E. ALL RECOMMENDATIONS SHALL BE REVIEWED AND APPROVED BY THE CITY.
42. GRADING OPERATIONS AND MAINTENANCE OF EQUIPMENT WITHIN ONE HALF MILE OF HUMAN OCCUPANCY SHALL NOT BE CONDUCTED BETWEEN THE HOURS OF 5:30 P.M. AND 7:30 A.M. OR ANY TIME ON A SATURDAY, SUNDAY OR A CITY HOLIDAY.
43. THE DESIGN ENGINEER SHALL CERTIFY ALL HORIZONTAL LINES AND VERTICAL GRADES PRIOR TO RELEASE OF GRADING.
44. CONSTRUCTION SITES SHALL BE MAINTAINED IN SUCH A CONDITION THAT AN ANTICIPATED STORM

DOES NOT CARRY WASTES OR POLLUTANTS OFF THE SITE.

- A. ALL EROSION PROTECTION DEVICES MUST BE IN PLACE EACH DAY THE RAIN PROBABILITY FORECAST IS EQUAL TO OR GREATER THAN 40%. AFTER A RAIN EVENT (OR DURING AN EXTENDED EVENT IF NECESSARY), ALL EROSION PROTECTION DEVICES SHALL BE INSPECTED AND REPAIRED/CLEANED AS NEEDED TO ENSURE PROPER FUNCTION.**
 - B. DISCHARGES OF MATERIAL OTHER THAN STORMWATER ("NON-STORMWATER" DISCHARGES) ARE ALLOWED ONLY WHEN NECESSARY FOR PERFORMANCE AND COMPLETION OF CONSTRUCTION PRACTICES AND WHERE THEY DO NOT: CAUSE OR CONTRIBUTE TO A VIOLATION OF ANY WATER QUALITY STANDARD; CAUSE OR THREATEN TO CAUSE POLLUTION, CONTAMINATION, OR NUISANCE; OR CONTAIN A HAZARDOUS SUBSTANCE IN A QUANTITY REPORTABLE UNDER FEDERAL REGULATIONS 40 CFR PARTS 117 AND 302. SITE SHALL INCLUDE BEST MANAGEMENT PRACTICES (BMPS) TO REDUCE THE QUANTITY (AMOUNT AND NUMBER OF INCIDENTS) OF NON-STORMWATER DISCHARGES AND TO IMPROVE THE QUALITY OF ANY NON-STORMWATER DISCHARGES.**
 - C. STORMWATER AND NON-STORMWATER DISCHARGES SHALL NOT CARRY WASTES OR POLLUTANTS OFF THE SITE. POTENTIAL POLLUTANTS INCLUDE BUT ARE NOT LIMITED TO: SOLID OR LIQUID CHEMICAL SPILLS; WASTES FROM PAINTS, STAINS, SEALANTS, GLUES, LIMES, PESTICIDES, HERBICIDES, WOOD PRESERVATIVES AND SOLVENTS; ASBESTOS FIBERS, PAINT FLAKES OR STUCCO FRAGMENTS; FUELS, OILS, LUBRICANTS, AND HYDRAULIC, RADIATOR OR BATTERY FLUIDS; FERTILIZERS, VEHICLE/EQUIPMENT WASH WATER AND CONCRETE WASH WATER; CONCRETE, DETERGENT OR FLOATABLE WASTES; WASTES FROM ANY ENGINE/EQUIPMENT STEAM CLEANING OR CHEMICAL DEGREASING; AND SUPERCHLORINATED POTABLE WATER LINE FLUSHINGS.**
 - D. DURING CONSTRUCTION, DISPOSAL OF SUCH MATERIALS SHOULD OCCUR IN A SPECIFIED AND CONTROLLED TEMPORARY AREA ON-SITE, PHYSICALLY SEPARATED FROM POTENTIAL STORM WATER AND NON-STORMWATER RUN-OFF, WITH ULTIMATE DISPOSAL IN ACCORDANCE WITH LOCAL, STATE AND FEDERAL REQUIREMENTS.**
 - E. THE PERMITTEE SHALL NOTIFY ALL GENERAL CONTRACTORS, SUBCONTRACTORS, MATERIAL SUPPLIERS, LESSEES AND PROPERTY OWNERS THAT THE DISCHARGE OF POLLUTANTS INTO THE STORM DRAIN SYSTEM OR OTHER WATERSHED DRAINAGE FEATURES IS PROHIBITED.**
- 45. DEWATERING OF CONTAMINATED GROUNDWATER OR DISCHARGING CONTAMINATED SOILS VIA SURFACE EROSION IS PROHIBITED. DEWATERING OF NON-CONTAMINATED GROUNDWATER REQUIRES A NATIONAL POLLUTANT DISCHARGE ELIMINATION SYSTEM PERMIT FROM THE RESPECTIVE STATE REGIONAL WATER QUALITY CONTROL BOARD.**
- 46. PRIOR TO CONSTRUCTION, ALL SURVEY MONUMENTS AND CENTERLINE TIES ARE TO BE LOCATED IN THE FIELD. UPON COMPLETION OF CONSTRUCTION, ALL DAMAGED OR DESTROYED CENTERLINE TIES AND SURVEY MONUMENTS ARE TO BE RESET AND "CORNER RECORDS" PREPARED FOR SURVEY MONUMENTS FOR SUBMISSION TO THE CITY'S ENGINEERING DIVISION AND FILING WITH THE COUNTY SURVEYOR IN COMPLIANCE WITH AB1414. THIS MUST BE COMPLETED PRIOR TO CERTIFYING COMPLETION OF THE PROJECT. ALL RESTORATIONS OF SURVEY MONUMENTS SHALL BE CERTIFIED BY THE DESIGN REGISTERED ENGINEER IN ACCORDANCE WITH SECTION 8771 OF THE BUSINESS AND PROFESSIONS CODE.**
- 47. PRIOR TO GRADING, HYDRO AUGERS ARE TO BE INSTALLED AT THE TOE OF SLOPE FACE (IF APPLICABLE). ACTUAL LOCATIONS WILL BE DETERMINED BY SOILS ENGINEER IN THE FIELD. (MAXIMUM SPACING 50 FEET).**

48. A CITY OF SAN CLEMENTE ENCROACHMENT PERMIT WILL BE REQUIRED PRIOR TO ANY GRADING OR WORK IN CITY'S PUBLIC RIGHT-OF-WAY.

**CITY OF SAN CLEMENTE
GENERAL NOTES
FOR
SEWER SYSTEMS**

1. ALL WORK SHALL CONFORM TO THE STANDARD PLANS AND SPECIFICATIONS OF THE CITY OF SAN CLEMENTE, ORANGE COUNTY PUBLIC FACILITIES & RESOURCES DEPARTMENT (PF&RD), AND STANDARD SPECIFICATIONS FOR PUBLIC WORKS CONSTRUCTION, LATEST EDITION. ALL WORK SHALL BE SUBJECT TO THE CITY ENGINEER'S ACCEPTANCE AS A CONDITION OF COMPLETION OF WORK BY THE CONTRACTOR.
2. THE CONTRACTOR SHALL NOTIFY THE CITY OF SAN CLEMENTE'S INSPECTOR AT LEAST 48 HOURS PRIOR TO ANY CONSTRUCTION AT (949) 361-6131.
3. ALL WATER AND SEWERAGE FACILITIES SHALL CONFORM TO THE CITY'S "STANDARD PROVISIONS AND STANDARD DRAWINGS FOR THE CONSTRUCTION OF WATER AND SEWERAGE FACILITIES", LATEST EDITION, HEREIN REFERRED AS THE "CITY WATER AND SEWER STANDARDS". THE CONTRACTOR SHALL HAVE A COPY OF APPROVED PLANS, PERMITS AND THE WATER AND SEWER STANDARDS ON THE JOB AT ALL TIMES.
4. FACILITIES NOT IN DEDICATED CITY RIGHT OF WAY SHALL NOT BE CONNECTED TO A PUBLIC FACILITY UNTIL THE CITY HAS ACCEPTED AND RECORDED AN EASEMENT FOR THE FACILITIES. A COPY OF THE RECORDED EASEMENT SHALL BE PROVIDED TO THE INSPECTOR PRIOR TO ANY CONNECTION BEING MADE IN THE FIELD.
5. CONNECTION TO EXISTING MANHOLE, WHERE STUBS DO NOT EXIST, SHALL BE DONE BY CORE DRILLING.
6. WORK NOT DONE IN THE PRESENCE OF THE CITY INSPECTOR IS SUBJECT TO REJECTION.
7. THE CONTRACTOR SHALL REMOVE OR ABANDON ALL UNUSED WATER AND SEWERAGE FACILITIES PER THE WATER AND SEWER STANDARDS.
8. THE SEWER MAIN SHALL BE BALLED, CLEANED AND TESTED PRIOR TO ACCEPTANCE BY THE CITY. FINAL BALLING AND TESTING TO BE DONE IN THE PRESENCE OF THE CITY INSPECTOR AFTER APPROPRIATE WORK IS COMPLETE AND STREET HAS BEEN PAVED AND MANHOLES RAISED TO GRADE.
9. MINIMUM SEWER COVER SHALL BE 6 FEET BELOW SUBGRADE. IF, DURING CONSTRUCTION, SEWER IS FOUND TO HAVE LESS THAN 6 FEET OF COVER, SEWER SHALL BE ENCASED IN CONCRETE.
10. ALL LATERAL LOCATIONS SHALL BE CLEARLY MARKED WITH A 2 INCH HIGH "S" CHISELED IN THE CURB FACE BY THE CONTRACTOR.
11. STATIONS SHOWN THUS 0+00 AS SHOWN ON THE PLAN AND PROFILE ARE SEWER STATIONS AND ARE INDEPENDENT OF STREET STATIONS AND ARE STATIONS ALONG CENTERLINE OF SEWER FROM DOWNSTREAM MANHOLE.
12. SEWER LINE DISTANCE SHOWN IN PROFILE IS THE HORIZONTAL DISTANCE MEASURED BETWEEN MANHOLES.

**CITY OF SAN CLEMENTE
GENERAL NOTES
FOR
STORM DRAIN PLANS**

1. ALL WORK SHALL CONFORM TO THE STANDARD PLANS AND SPECIFICATIONS OF THE CITY OF SAN CLEMENTE, ORANGE COUNTY PUBLIC FACILITIES & RESOURCES DEPARTMENT (PF&RD), AND STANDARD SPECIFICATIONS FOR PUBLIC WORKS CONSTRUCTION, LATEST EDITION. ALL WORK SHALL BE SUBJECT TO THE CITY ENGINEER'S ACCEPTANCE AS A CONDITION OF COMPLETION OF WORK BY THE CONTRACTOR.
2. THE CONTRACTOR SHALL NOTIFY THE CITY OF SAN CLEMENTE'S INSPECTOR AT LEAST 48 HOURS PRIOR TO ANY CONSTRUCTION AT (949) 361-6131.
3. THE CONTRACTOR SHALL ALSO NOTIFY THE DISTRICT'S INSPECTOR AT LEAST 48 HOURS PRIOR TO COMMENCEMENT OF ANY CONSTRUCTION BY TELEPHONING 714/567-7800, OR BY WRITING TO THE ORANGE COUNTY PUBLIC FACILITIES & RESOURCES DEPARTMENT (PF&RD), ATTENTION - CONSTRUCTION, P. O. BOX 4048, SANTA ANA, CALIFORNIA 92702.
4. ALL REINFORCED CONCRETE PIPE SHALL BE BEDDED IN ACCORDANCE WITH CITY OF SAN CLEMENTE WATER AND SEWERAGE STANDARD PLAN WS-1.
5. ALL CONCRETE IN REINFORCED CONCRETE STRUCTURES SHALL BE 3,000 PSI, PORTLAND CEMENT CONCRETE.
6. ALL PIPE LENGTHS ARE HORIZONTAL PROJECTS, UNLESS OTHERWISE SHOWN.
7. CONTRACTOR SHALL OBTAIN PERMIT FROM PF&RD AND CALTRANS FOR WORK WITHIN THEIR RIGHT-OF-WAY.
8. LOCATIONS OF PUBLIC UTILITIES SHOWN HAVE BEEN DETERMINED FROM AVAILABLE INFORMATION. HOWEVER, IT SHALL BE THE RESPONSIBILITY OF THE CONTRACTOR TO DETERMINE THE TRUE LOCATION OF ANY EXISTING UTILITIES AND TO EXERCISE PROPER PRECAUTIONS TO AVOID INJURY OR DAMAGED THERETO.
9. PRIOR TO THE PLACEMENT OF STORM DRAIN IMPROVEMENTS, THE DEVELOPER'S SOILS ENGINEER SHALL CERTIFY IN WRITING TO THE CITY'S INSPECTOR THAT THE STORM DRAIN SUBGRADE IS OF ADEQUATE STRENGTH TO SUPPORT THE STRUCTURES AND ANY ANTICIPATED LOADS.
10. ALL TRENCH EXCAVATIONS SHALL CONFORM TO STATE OF CALIFORNIA CONSTRUCTION SAFETY ORDERS.
11. MANHOLE RINGS AND COVERS SHALL BE "ALHAMBRA FOUNDRY A-1499" OR EQUAL PER ASTM-A-48, CLASS 40 IRON, DIPPED TWICE IN ASPHALT OR COAL TAR OIL, HAVE 24" CLEAR OPENING, AND STAMPED "SD" ON COVER SHALL CONFORM TO APPLICABLE A.S.T.M. STANDARDS.
12. ALL FILL MATERIAL SHALL BE COMPACTED TO 90% RELATIVE COMPACTION AS DETERMINED BY CALIFORNIA TEST METHOD 216F.
13. ALL MATERIALS TESTING FOR THE DRAINAGE FACILITIES SHALL BE PROVIDED BY THE CONTRACTOR OR DEVELOPER IN ACCORDANCE WITH THE NUMBER, LOCATION AND FREQUENCY REQUESTED BY THE CITY'S INSPECTOR.
14. PRIOR TO CONSTRUCTION, ALL SURVEY MONUMENTS AND CENTERLINE TIES ARE TO BE LOCATED IN THE FIELD. UPON COMPLETION OF CONSTRUCTION, ALL DAMAGED OR DESTROYED CENTERLINE TIES AND SURVEY MONUMENTS ARE TO BE RESET AND "CORNER RECORDS" PREPARED FOR SURVEY MONUMENTS FOR SUBMISSION TO THE CITY'S ENGINEERING DIVISION AND FILING WITH THE COUNTY SURVEYOR IN COMPLIANCE WITH AB1414. THIS MUST BE COMPLETED PRIOR TO CERTIFYING COMPLETION OF THE PROJECT. ALL RESTORATIONS OF SURVEY MONUMENTS SHALL BE CERTIFIED BY THE DESIGN REGISTERED ENGINEER IN ACCORDANCE WITH SECTION 8771 OF THE BUSINESS AND PROFESSIONS CODE.

**CITY OF SAN CLEMENTE
GENERAL NOTES
FOR
STREET IMPROVEMENT PLANS**

1. ALL WORK SHALL CONFORM TO THE STANDARD PLANS AND SPECIFICATIONS OF THE CITY OF SAN CLEMENTE, ORANGE COUNTY PUBLIC FACILITIES & RESOURCES DEPARTMENT (PF&RD), AND STANDARD SPECIFICATIONS FOR PUBLIC WORKS CONSTRUCTION, LATEST EDITION. ALL WORK SHALL BE SUBJECT TO THE CITY ENGINEER'S ACCEPTANCE AS A CONDITION OF COMPLETION OF WORK BY THE CONTRACTOR.
2. ALL UNDERGROUND UTILITIES SHALL BE INSTALLED PRIOR TO SURFACING OF THE STREETS.
3. ALL MONUMENTS SHALL BE SET IN ACCORDANCE WITH THE RECORDED TRACT MAP AND THE REQUIREMENTS OF THE CITY ENGINEER.
4. THE STRUCTURAL SECTIONS SHALL BE RECOMMENDED BY A GEOTECHNICAL REPORT AND SUBMITTED TO THE CITY OF SAN CLEMENTE FOR APPROVAL UPON COMPLETION OF ROUGH GRADING. MINIMUM STRUCTURAL SECTION SHALL BE 4" A.C. OVER 7" A.B.
5. ALL EXISTING STRUCTURES AND SUBSTRUCTURES SHOWN ON THESE PLANS ARE FROM AVAILABLE RECORDS. IT IS THE RESPONSIBILITY OF THE CONTRACTOR TO VERIFY THE LOCATION OF SAID STRUCTURES AND SUBSTRUCTURES AND PROTECT THEM IN PLACE WHETHER OR NOT SHOWN ON THESE PLANS.
6. GUTTERS WITH LESS THAN 2% GRADE SHALL BE WATER CHECKED DURING FINISHING TO AVOID PONDING.
7. CURB ALIGNMENT AND GRADE SHALL NOT DEVIATE FROM PLANS MORE THAN .02' WITHIN A 5' INTERVAL.
8. WHEN WORKING IN STREETS ADJACENT TO STREETS ALREADY IN USE, THE CONTRACTOR SHALL USE PROPER SAFETY SIGNING AND BARRICADING SUCH AS THOSE GIVEN IN THE W.A.T.C.H. MANUAL OR THE MANUAL OF WARNING LIGHTS. LIGHTS AND DEVICES FOR USE IN PERFORMANCE OF WORKS IN HIGHWAYS PUBLISHED BY THE CALIFORNIA DEPARTMENT OF PUBLIC WORKS.
9. WORKING HOURS FROM 8:00 AM TO 4:30 PM, MONDAY THROUGH FRIDAY, EXCEPT CITY HOLIDAYS, SHALL BE MAINTAINED. ANY EXCEPTIONS SHALL BE PER CITY ENGINEER'S APPROVAL.
10. CONTRACTOR AGREES THAT HE SHALL ASSUME SOLE AND COMPLETE RESPONSIBILITY FOR JOB SITE CONDITIONS DURING THE COURSE OF THE CONSTRUCTION OF THIS PROJECT, INCLUDING SAFETY OF ALL PERSONS AND PROPERTY; THAT THIS REQUIREMENT SHALL APPLY CONTINUOUSLY AND NOT BE LIMITED TO NORMAL WORKING HOURS; AND THAT THE CONTRACTOR SHALL DEFEND, INDEMNIFY AND HOLD THE OWNER AND THE ENGINEER HARMLESS FROM ANY AND ALL LIABILITY, REAL OR ALLEGED, IN CONNECTION WITH THE PERFORMANCE OF THE WORK ON THIS PROJECT, EXCEPTING FOR LIABILITY ARISING FROM SOLE NEGLIGENCE OF THE OWNER OR THE ENGINEER.
11. CONTRACTOR SHALL VERIFY ALL CONDITIONS AND DIMENSIONS AND SHALL REPORT ALL DISCREPANCIES TO THE CITY ENGINEER PRIOR TO THE COMMENCEMENT OF WORK.
12. CONTRACTOR SHALL PROVIDE A PRIME COAT OF GRADE SC-250 LIQUID ASPHALT APPLIED AT THE RATE OF 0.10 TO 0.25 GALLON PER YARD.
13. CONTRACTOR SHALL PROVIDE A SLURRY SEAL OF EMULSIFIED ASPHALT GRADE SS-1H APPLIED AT THE RATE OF 0.1 TO 0.2 GALLON PER SQUARE YARD AS REQUIRED BY THE CITY ENGINEER.

14. APPROVED SOIL STERILANT IS REQUIRED UNDER ALL NEW ASPHALT PAVEMENTS PRIOR TO PLACEMENT.
15. CONTRACTOR SHALL PROVIDE CRUSHED AGGREGATE BASE AS SPECIFIED IN SECTION 200-2.2 OF THE STANDARD SPECIFICATIONS FOR PUBLIC WORKS CONSTRUCTION, LATEST EDITION, WHENEVER A.B. OR UNTREATED BASE MATERIAL IS INDICATED, UNLESS OTHERWISE WAIVED IN WRITING BY THE CITY ENGINEER.
16. DESIGN ENGINEER SHALL CERTIFY ALL LINES AND GRADES PER APPROVED PLANS.
17. MAILBOXES SHALL BE INSTALLED IN LOCATIONS APPROVED BY LOCAL POSTMASTER AND PER PF&RD STANDARD PLAN NO. 1205.
18. ALL CONCRETE CURBS AND GUTTERS AND SIDEWALKS WITHIN PUBLIC RIGHT-OF-WAY SHALL BE CONSTRUCTED ON A MINIMUM OF 4" AGGREGATE BASE.
19. ALL CROSS GUTTERS AND SPANDRELS WITHIN PUBLIC RIGHT-OF-WAY SHALL BE CONSTRUCTED ON A MINIMUM OF 6" AGGREGATE BASE.
20. PRIOR TO CONSTRUCTION, ALL SURVEY MONUMENTS & CENTERLINE TIES ARE TO BE LOCATED IN THE FIELD. UPON COMPLETION OF CONSTRUCTION, ALL DAMAGED OR DESTROYED CENTERLINE TIES OR SURVEY MONUMENTS ARE TO BE RESET AND "CORNER RECORDS" PREPARED FOR SURVEY MONUMENT FOR SUBMISSION TO THE CITY'S ENGINEERING DIVISION AND FILING WITH THE COUNTY SURVEYOR IN COMPLIANCE WITH AB1414. THIS MUST BE COMPLETED PRIOR TO CERTIFYING COMPLETION OF THE PROJECT. ALL RESTORATIONS OF SURVEY MONUMENTS SHALL BE CERTIFIED BY THE DESIGN REGISTERED ENGINEER IN ACCORDANCE WITH SECTION 8771 OF THE BUSINESS AND PROFESSIONS CODE.
21. PRIOR TO APPROVAL OF IMPROVEMENTS BY THE ENGINEERING DIVISION AND ACCEPTANCE BY THE CITY, CENTERLINE MONUMENTS SHALL BE SET AT ALL POINTS OF INTERSECTION STREETS BEGINNING OF CURVES, POINTS OF REVERSE CURVE, END OF CURVES, CENTER OF CUL-DE-SACS, AND ANY OTHER POINTS DESIGNATED BY THE CITY ENGINEER OR HIS DESIGNEE. TIES TO MONUMENTS SHALL BE SET WITHIN 30 DAYS AFTER COMPLETION OF IMPROVEMENTS AND COPY OF SAID TIES SHALL BE FURNISHED TO THE CITY ENGINEER.
22. CONSTRUCTION SITES SHALL BE MAINTAINED IN SUCH A CONDITION THAT AN ANTICIPATED STORM DOES NOT CARRY WASTES OR POLLUTANTS OFF THE SITE.

DISCHARGES OF MATERIAL OTHER THAN STORMWATER ARE ALLOWED ONLY WHEN NECESSARY FOR PERFORMANCE AND COMPLETION OF CONSTRUCTION PRACTICES AND WHERE THEY DO NOT: CAUSE OR CONTRIBUTE TO A VIOLATION OF ANY WATER QUALITY STANDARD; CAUSE OR THREATEN TO CAUSE POLLUTION, CONTAMINATION, OR NUISANCE; OR CONTAIN A HAZARDOUS SUBSTANCE IN A QUANTITY REPORTABLE UNDER FEDERAL REGULATIONS 40 CFR PARTS 117 AND 302.

POTENTIAL POLLUTANTS INCLUDE BUT ARE NOT LIMITED TO: SOLID OR LIQUID CHEMICAL SPILLS; WASTES FROM PAINTS, STAINS, SEALANTS, GLUES, LIMES, PESTICIDES, HERBICIDES, WOOD PRESERVATIVES AND SOLVENTS; ASBESTOS FIBERS, PAINT FLAKES OR STUCCO FRAGMENTS; FUELS, OILS, LUBRICANTS, AND HYDRAULIC, RADIATOR OR BATTERY FLUIDS; FERTILIZERS, VEHICLE/EQUIPMENT WASH WATER AND CONCRETE WASH WATER; CONCRETE, DETERGENT OR FLOATABLE WASTES; WASTES FROM ANY ENGINE/EQUIPMENT STEAM CLEANING OR CHEMICAL DEGREASING; AND SUPERCHLORINATED POTABLE WATER LINE FLUSHINGS.

DURING CONSTRUCTION, DISPOSAL OF SUCH MATERIALS SHOULD OCCUR IN A SPECIFIED AND CONTROLLED TEMPORARY AREA ON-SITE, PHYSICALLY SEPARATED FROM POTENTIAL STORM WATER RUN-OFF, WITH ULTIMATE DISPOSAL IN ACCORDANCE WITH LOCAL, STATE AND FEDERAL REQUIREMENTS.

24. DEWATERING ON CONTAMINATED GROUNDWATER, OR DISCHARGING CONTAMINATED SOILS VIA SURFACE EROSION IS PROHIBITED. DEWATERING OF NON-CONTAMINATED GROUNDWATER REQUIRES A NATIONAL POLLUTANT DISCHARGE ELIMINATION SYSTEM PERMIT FROM THE RESPECTIVE STATE REGIONAL WATER QUALITY CONTROL BOARD.

SPECIAL NOTES

1. PURSUANT TO STREET AND HIGHWAY CODE 1805.5, ALL CATCH BASIN GRATES SHALL BE OF A TYPE WHICH IS "NON-HAZARDOUS" TO BICYCLE RIDERS.
2. PURSUANT TO STATE LAW, THE CONTRACTOR SHALL CONSTRUCT A WHEELCHAIR RAMP AT ALL STREET INTERSECTIONS.

NOTICE TO CONTRACTOR

NOTIFY THE FOLLOWING COMPANIES 48 HOURS PRIOR TO CONSTRUCTION FOR LOCATION OF UNDERGROUND INSTALLATION:

(PLAN PREPARER TO PROVIDE CURRENT PHONE NUMBERS)

- | | |
|------------------------------------|-----------------|
| 1. UNDERGROUND SERVICE ALERT | (PHONE #) _____ |
| 2. PACIFIC BELL | (PHONE #) _____ |
| 3. SAN DIEGO GAS & ELECTRIC | (PHONE #) _____ |
| 4. SOUTHERN CALIFORNIA GAS COMPANY | (PHONE #) _____ |
| 5. COX COMMUNICATIONS | (PHONE #) _____ |

STREET LIGHTING NOTES

1. STREET LIGHTING SHALL CONFORM TO STANDARD PLANS AND SPECIFICATIONS OF THE CITY OF SAN CLEMENTE, ORANGE COUNTY PUBLIC FACILITIES & RESOURCES DEPARTMENT (PF&RD), LATEST EDITION.
2. STREET LIGHT CONTRACTOR SHALL SUBMIT "AS BUILT" UNDERGROUND WIRING PLANS TO THE CITY.
3. EACH STREET LIGHT SHALL HAVE ITS OWN PULL BOX, DOUBLE 15 AMP, FUSE AND GROUND ROD. ALL WIRE SHALL BE COPPER.
4. CONDUIT SHALL BE SCHEDULE 40, P.V.C. 1-1/4" MINIMUM DIAMETER. MINIMUM OF 36" BELOW TOP OF CURB.

STRIPING GENERAL NOTES

1. ALL WORK AND EQUIPMENT SHALL CONFORM TO THE REQUIREMENTS OF THE STATE OF CALIFORNIA, DEPARTMENT OF TRANSPORTATION (CALTRANS) STANDARD PLANS AND SPECIFICATIONS, LATEST EDITION.
2. THE CONTRACTOR SHALL RESTORE OR REPLACE ALL EXISTING IMPROVEMENTS DISTURBED DURING CONSTRUCTION INCLUDING, BUT NOT LIMITED TO STREET STRIPING, LANDSCAPING, AND SIGNS.
3. ALL STRIPING AND PAVEMENT LEGENDS TO BE INSTALLED PER STATE OF CALIFORNIA DEPARTMENT OF TRANSPORTATION TRAFFIC MANUAL, LATEST EDITION. NEW STRIPING SHALL NOT BE PLACED UNTIL SPOTTED AND SPOTTING APPROVED BY THE CITY ENGINEER.
4. ALL CONFLICTING STRIPING SHALL BE WET OR VACUUM SANDBLASTED. CONFLICTING RAISED PAVEMENT MARKERS SHALL ALSO BE REMOVED.
5. ALL WORK SHALL BE COORDINATED WITH AND COMPLETED TO THE SATISFACTION OF THE CITY OF SAN CLEMENTE, TRAFFIC DIVISION.
6. FIRE HYDRANT RAISED PAVEMENT MARKERS SHALL BE INSTALLED PER CITY OF SAN CLEMENTE STANDARDS.
7. ALL POSTS SHALL BE SQUARE TUBE (PF&RD STANDARD PLAN NO. 1417).
8. ALL PAVEMENT ARROWS SHALL CONFORM TO THE CITY OF SAN CLEMENTE STENCILS.
9. ALL SIGN SHALL BE REFLECTORIZED AND SHALL CONFORM TO THE CITY OF SAN CLEMENTE SPECIFICATIONS. INSTALLTION SHALL CONFORM TO PF&RD STANDARD PLANS AND TRAFFIC MANUAL.
10. ALL PAVEMENT LEGENDS SHALL BE PLACED IN THE CENTER OF THE TRAVEL LANE (EXCLUDING 8' OF PARKING LANE).
11. INSTALL THERMOPLASTIC (ETM) CROSSWALK, PAVEMENT ARROW MESSAGED, AND LIMIT LINES PER CALTRANS STANDARD PLANS.

**CITY OF SAN CLEMENTE
GENERAL NOTES
FOR
TRAFFIC CONTROL PLANS**

1. ALL WORK, DEVICES AND MATERIALS SHALL COMPLY WITH THE CALTRANS MANUAL OF TRAFFIC CONTROLS IN CONSTRUCTION AND MAINTENANCE ZONES AND WITH THE WORK AREA TRAFFIC CONTROL HANDBOOK. (LATEST EDITION)
2. ALL TRAFFIC DETOURS SHALL BE APPROVED BY THE ENGINEERING DIVISION. THE CONTRACTOR SHALL OBTAIN A N ENCROACHMENT PERMIT FROM THE ENGINEERING DIVISION PRIOR TO PERFORMING ANY WORK
3. ANY WORK WITHIN CALTRANS RIGHTS-OF-WAY MUST BE APPROVED AND COORDINATED WITH CALTRANS
4. ALL LOOPS DAMAGED BY THE CONTRACTORS OPERATIONS SHALL BE REPAIRED WITHIN TWO (2) WORKING DAYS OF FINAL PAVING OPERATIONS.
5. THE CONTRACTOR SHALL MAINTAIN 10' MINIMUM TRAVEL LANES, 12' MINIMUM IF ADJACENT TO A CURBED GUTTER.
6. NO "CROSSOVER" TRAFFIC PATTERNS REQUIRING TAFFIC TO DRIVE ON THE LEFT SIDE OF ANY MEDIAN SHALL BE PERMITTED UNLESS SPECIFICALLY APPROVED BY THE ENGINEERING DIVISION.
7. THE CONTRACTOR SHALL MAINTAIN ON A 24-HOUR BASIS ALL SIGNS, DELINEATORS, BARRACADES, ETC., TO INSURE PROPER FLOW AND SAFETY OF TRAFFIC, THE CONTRACTOR SHALL HAVE ALL TRAFFIC CONTROLS PROPERLY INSTALLED PRIOR TO THE BEGINNING OF WORK AND SHALL NOT SWITCH TRAFFIC CONTROL TO SUBSEQUENT PHASES OF WORK DURING WORKING HOURS.
8. THE CONTRACTOR SHALL BE RESPONSIBLE FOR THE PLACEMENT OF ADDITIONAL DEVICES NECESSARY TO ASSURE SAFETY TO THE PUBLIC AT ALL TIMES DURING CONSTRUCTION.
9. THE PROVISION OF THIS PERMIT SHALL APPLY UNTIL ALL PHASES OF THE WORK WITHIN PUBLIC RIGHT-OF-WAY ARE COMPLETED.
10. CONSTRUCTION OPERATIONS SHALL BE CONDUCTED IN A MANNER AS TO CAUSE AS LITTLE INCONVENIENCE AS POSSIBLE TO ABUTTING PROPERTY OWNERS.
11. THE CONTRACTOR SHALL PROVIDE FOR ACCESS TO ALL ADJACENT PROPETIES AT ALL TIMES, UNLESS APPROVED OTHERWISE BY THE ENGINEER.
12. THE CONTRACTOR SHALL PROVIDE SAFE PEDESTRIAN ACCESS AT ALL TIMES.
13. TEMPORARY FENCING SHALL BE PLACED AROUND OPEN TRENCHES IN THE PUBLIC RIGHT OF WAY DURING NON CONSTRUCTION HOURS.
14. POST "TEMPORARY NO PARKING TOW AWAY" SIGNS DEFINING THE TIME AND DATE OF THE RESTRICTION 24 HOURS PRIOR TO WORK EXCEPT AS FOLLOWS: 36 HOURS PRIOR TO WORK SCHEDULED FOR A MONDAY OR THE DAY AFTER A HOLIDAY AND 45 HOURS PRIOR TO WORK SCHEDULED FOR A WEEKEND OR A HOLIDAY.
15. NOTIFY BUSINESSES ADJACENT TO THE WORK AREA 7 DAYS PRIOR TO THE START OF WORK.

16. THE CONTRACTOR SHALL BE RESPONSIBLE TO NOTIFY RESIDENTS AND BUSINESSES, IN WRITING 7 DAYS IN ADVANCE OF ANY WORK THAT INVOLVES LIMITED ACCESS. THE CONTRACTOR SHALL PROVIDE WRITTEN VERIFICATION TO THE ENGINEER THAT THIS HAS BEEN ACCOMPLISHED.
17. NOTIFY THE APPROPRIATE WASTE DISPOSAL COMPANY OF ANY LIMITATION TO ACCESS FOR TRASH PICK UP.
18. COORDINATE WITH THE ORANGE COUNTY TRANSPORTATION AUTHORITY TO ENSURE SAFE OPERATION OF BUSES AND ACCESS TO BUS STOPS IN THE CONSTRUCTION AREA.
19. ALL SIGNS SHALL BE REFLECTORIZED AND STANDARD IN SIZE. WHEN TRAFFIC CONTROL CONFLICTS WITH EXISTING SIGNING, THE CONTRACTOR SHALL COVER EXISTING SIGNS IN A MANNER APPROVED BY THE ENGINEER.
20. TYPE I OR II BARRICADES MAY BE USED IN ADDITION TO DELINEATORS AT THE DISCRETION OF THE CONTRACTOR, WHEN THEY ARE INTENDED TO PROVIDE ADDITIONAL EMPHASIS IN AREAS WHERE WORKERS ARE PRESENT.
21. THE CONTRACTOR SHALL UTILIZE FLAG MEN DURING WORKING HOURS AS DEEMED NECESSARY BY THE CITY.
22. WHERE LIGHTS ARE USED TO DELINEATE THE TRAVEL WAY THROUGH THE WORK AREA, THEY SHALL BE TYPE "C" STEADY BURN LAMPS.
23. FLASHING YELLOW BEACONS, TYPE "B" SHALL BE USED ON ALL C18 SIGNS AND TYPE II OR III BARRICADES GUARDING THE WORK AREA FOR OVER NIGHT WORK. THE FLASHERS SHALL NOT BE USED TO CHANNELIZE, SEPARATE OR DELINEATE THE PATH THAT TRAFFIC IS TO FOLLOW.
24. ALL CONFLICTING STRIPES, PAVEMENT MARKING AND LEGENDS SHALL BE COMPLETELY REMOVED BY ABRASIVE BLAST CLEANING OR OTHER METHOD APPROVED BY THE ENGINEER WITH IMMEDIATE CLEANUP OF RESIDUE.
25. FOR DELINEATION OF NEW REQUIRED VEHICLE PATHS, USE PRESSURE SENSITIVE TRAFFIC MARKING TAPE OR TYPICAL STRIPING PAINT TO SUPPLEMENT THE CHANNELIZING DEVICES.
26. TRAFFIC MARKINGS INSTALLED DUE TO DETOUR REQUIREMENTS SHALL BE REMOVED BY WET SANDBLASTING IMMEDIATELY AFTER COMPLETION OF WORK.
27. PROVIDE TEMPORARY RESTRIPIING AT THE CONCLUSION OF EACH WORKING DAY FOR ALL CENTERLINE OR LANE LINE WHICH IS OBLITERATED BY CONSTRUCTION.
28. STRIPING AND MARKING SHALL CONFORM TO THE STATE OF CALIFORNIA STANDARD PLANS AND SPECIFICATIONS AND THE CITY OF SAN CLEMENTE STANDARDS AND SHALL CONFORM TO CITY OF SAN CLEMENTE STENCILS.
29. ALL STRIPING AND PAVEMENT MARKINGS DAMAGED BY CONSTRUCTION SHALL BE REPLACED IN KIND. PAINTED STRIPING SHALL BE REPLACED WITH 2 COATS OF PAINT; THE SECOND COAT SHALL BE APPLIED 7 DAYS AFTER THE FIRST COAT.
30. THE CONTRACTOR SHALL BE RESPONSIBLE FOR MODIFYING TRAFFIC SIGNALS AS REQUIRED TO PROVIDE FOR SAFE AND EFFICIENT MOVEMENT OF TRAFFIC; INCLUDING PHASE CHANGES, COVERING OF VEHICLE HEADS, OR OTHER HARDWARE MODIFICATIONS. THE CONTRACTOR SHALL COORDINATE WITH THE CITY OF SAN CLEMENTE MAINTENANCE SERVICES AT (949) 368-6347, 2 WORKING DAYS PRIOR TO WORK AFFECTING SIGNAL OPERATIONS OR EQUIPMENT.
31. THE CONTRACTOR SHALL BE RESPONSIBLE FOR THE LOCATION AND PROTECTION OF SIGNAL

AND INTERCONNECT CONDUITS. WHERE DAMAGE IS CAUSED BY THE CONTRATOR'S OPERATIONS, THE CONTRACTOR SHALL IMMEDIATELY REPLACE THE DAMAGED CITY FACILTITY AT NO COST TO THE CITY OF SAN CLEMENTE.

- 32. TRAFFIC SIGNAL SHUT DOWNS GREATER THAN 15 MINUTES SHALL REQUIRE THE PRESENCE OF TWO UNIFORMED POLICE OFFICERS TO DIRECT TRAFFIC. ALL RELATED EXPENSES AND WAGES OF THE POLICE OFFICERS SHALL BE BORNE BY THE CONTRACTOR.**
- 33. THE CONTRACTOR SHALL PROVIDE THE ENGINEER 72 HOURS ADVANCE NOTICE PRIOR TO ANY TRAFFIC SIGNAL SHUT DOWN AND SCHEDULING OF POLICE TRAFFIC CONTROL.**
- 34. AND DEVIATION FROM THE APPROVED PLANS OR CONDITIONS REQUIRES AN APPROVAL BY THE ENGINEER 48 HOURS PRIOR TO THE WORK.**
- 35. THE CONTRACTOR SHALL PLACE ADVANCED CONSTRUCTION NOTIFICATION SIGNING INDICATING THE UTILITY COMPANY OR CONTRACTOR PERFORMING THE WORK.**
- 36. A FLASHING ARROW BOARD SHALL BE USED FOR EACH LANE CLOSED.**

**CITY OF SAN CLEMENTE
GENERAL NOTES
FOR
WATER SYSTEMS**

1. ALL WORK SHALL CONFORM TO THE STANDARD PLANS AND SPECIFICATIONS OF THE CITY OF SAN CLEMENTE, ORANGE COUNTY PUBLIC FACILITIES & RESOURCES DEPARTMENT (PF&RD), AND STANDARD SPECIFICATIONS FOR PUBLIC WORKS CONSTRUCTION, LATEST EDITION. ALL WORK SHALL BE SUBJECT TO THE CITY ENGINEER'S ACCEPTANCE AS A CONDITION OF COMPLETION OF WORK BY THE CONTRACTOR.
2. THE CONTRACTOR SHALL NOTIFY THE CITY OF SAN CLEMENTE'S INSPECTOR AT LEAST 48 HOURS PRIOR TO ANY CONSTRUCTION AT (949) 361-6131.
3. ALL WATER AND SEWERAGE FACILITIES SHALL CONFORM TO THE CITY'S "STANDARD PROVISIONS AND STANDARD DRAWINGS FOR THE CONSTRUCTION OF WATER AND SEWERAGE FACILITIES", LATEST EDITION, HEREIN REFERRED AS THE "CITY WATER AND SEWER STANDARDS". THE CONTRACTOR SHALL HAVE A COPY OF APPROVED PLANS, PERMITS AND THE WATER AND SEWER STANDARDS ON THE JOB AT ALL TIMES.
4. FACILITIES NOT IN DEDICATED CITY RIGHT OF WAY SHALL NOT BE CONNECTED TO A PUBLIC FACILITY UNTIL THE CITY HAS ACCEPTED AND RECORDED AN EASEMENT FOR THE FACILITIES. A COPY OF THE RECORDED EASEMENT SHALL BE PROVIDED TO THE INSPECTOR PRIOR TO ANY CONNECTION BEING MADE IN THE FIELD.
5. WATER MAINS SHALL BE INSTALLED 6' OFF THE CURB FACE UNLESS OTHERWISE INDICATED, AND PRIOR TO PAVING OF THE STREET. COVER SHALL BE BETWEEN 36" MINIMUM AND 48" MAXIMUM FROM THE TOP OF PIPE TO THE FINISHED SURFACE.
6. FIRE HYDRANTS AND BLOW-OFFS SHALL BE INSTALLED IN ACCORDANCE WITH THE CITY STANDARDS UNLESS OTHERWISE DETAILED HEREIN. THEY ARE TO BE INSTALLED BEHIND CURBS. WHERE SIDEWALKS ARE ADJACENT TO CURBS, THEY SHALL BE INSTALLED BEHIND SIDEWALKS. FIRE HYDRANTS SHALL BE IN ACCORDANCE WITH THE CITY'S SPECIFICATIONS AND SHALL HAVE A CONCRETE PAD POURED AROUND THEM.
7. THE DEVELOPER SHALL FURNISH THE CITY WITH EASEMENTS FOR ALL PORTIONS OF THE SYSTEM OUTSIDE THE PUBLIC RIGHT-OF-WAY. THESE EASEMENTS SHALL BE READY FOR RECORDATION PRIOR TO SIGNING OF THE IMPROVEMENT PLANS.
8. ALL FLANGED CONNECTIONS SHALL BE COATED WITH TWO COATS OF 10 MILS EACH OF EC 244, OR APPROVED EQUAL, AFTER INSTALLATION, INCLUDING FLANGES.
9. ALL NUTS AND BOLTS USED FOR NON-PREASSEMBLED INSTALLATIONS OR UNDERGROUND SHALL BE STAINLESS STEEL, TYPE 316.
10. NO FACILITY TO BE BACKFILLED UNTIL INSPECTED BY THE CITY. UNDERGROUND WORK BACKFILLED BEFORE INSPECTION IS SUBJECT TO REJECTION.
11. SHUTDOWN OF EXISTING WATERLINES TO FACILITATE CONNECTION TO NEW FACILITIES SHALL BE COORDINATED WITH THE CITY WATER, ENGINEERING AND FIRE DEPARTMENTS.
12. WATER LATERALS FOR HOUSE CONNECTIONS SHALL BE INSTALLED TO 6" BACK OF FINAL CURBLINE AND 8" BELOW FINISHED GRADE PRIOR TO PAVING OF THE STREET. THE ANGLE METER STOP SHALL BE USED AS THE ONLY METHOD OF TERMINATING THE LATERAL. METER BOX SHALL BE J&R, W5 2-PIECE LID. ½" PVC CONDUIT AND BELDEN #84-50 WIRE SHALL BE INSTALLED PER STANDARD DRAWING W-14.
13. ALL WATER SERVICES SHALL BE SINGLE SERVICE AND INSTALLED PER CITY'S STANDARD

SPECIFICATIONS AND CITY STD W-1 OR W-2.

14. ALL WATER SERVICE LOCATIONS SHALL BE IDENTIFIED WITH A 2 INCH HIGH "W" STAMPED OR CHISLED INTO THE CURB FACE.
15. PIPE BEDDING SHALL BE INSTALLED PER CITY STANDARD WS-1.
16. ALL CONNECTIONS SHALL BE FIELD LOCK RUBBER GASKET PUSH-ON TYPE PER ANSI A21.53 (AWWA C-153), UNLESS OTHERWISE SHOWN ON PLANS, AND EXCEPT AT TEES AND CROSSES WHERE VALVES ARE REQUIRED. VALVES AND FITTINGS ARE TO BE JOINED BY FLANGE CONNECTIONS, UNLESS OTHERWISE SHOWN ON PLANS.
17. 8" WATER MAINS SHALL BE CLASS 200 AWWA C-900 P.V.C., OR CLASS 52 DUCTILE IRON.
18. VALVES AND FITTINGS SHALL BE CEMENT MORTAR-LINED AND COMPLETELY WRAPPED IN 4 MIL PLASTIC.
19. DISINFECTION SHALL BE ACCOMPLISHED UNDER THE DIRECTION OF THE CONSTRUCTION SUPERINTENDENT. LIQUID CHLORINE SHALL BE USED WITH A RESIDUAL OF 75 P.P.M. AT 24 HOURS.
20. FIRE HYDRANTS SHALL BE JONES J-4060D WET BARREL, CLOW NO. 860, PERVO 2420 SAFETY YELLOW COATING, WITH A 6 BOLT PATTERN.
21. PRIOR TO CONSTRUCTION, ALL SURVEY MONUMENTS AND CENTERLINE TIES ARE TO BE LOCATED IN THE FIELD. UPON COMPLETION OF CONSTRUCTION, ALL DAMAGED OR DESTROYED CENTERLINE TIES AND SURVEY MONUMENTS ARE TO BE RESET AND "CORNER RECORDS" PREPARED FOR SURVEY MONUMENTS FOR SUBMISSION TO THE CITY'S ENGINEERING DIVISION AND FILING WITH THE COUNTY SURVEYOR IN COMPLIANCE WITH AB1414. THIS MUST BE COMPLETED PRIOR TO CERTIFYING COMPLETION OF THE PROJECT. ALL RESTORATIONS OF SURVEY MONUMENTS SHALL BE CERTIFIED BY THE DESIGN REGISTERED ENGINEER IN ACCORDANCE WITH SECTION 8771 OF THE BUSINESS AND PROFESSIONS CODE.
22. ALL IRRIGATION SERVICES SHALL BE PROVIDED WITH APPROVED PRESSURE REGULATORS (WATT'S SERIES 223 OR APPROVED EQUAL) SET AT 60 P.S.I. ON THE CUSTOMER SIDE OF THE METER WHERE THE WATER MAIN PRESSURE EXCEEDS 70 P.S.I.
23. LOW-FLOW WATER DEVICES SHALL BE PROVIDED IN ACCORDANCE WITH CITY STANDARDS.
24. ALL SERVICES SHALL BE PROVIDED WITH CITY-APPROVED PRESSURE REGULATORS.
25. VALVES SHALL BE LOCATED AT ALL TEES.
26. THE CONTRACTOR SHALL REMOVE OR ABANDON ALL UNUSED WATER STUBS AND SERVICES TO THE SATISFACTION OF THE CITY INSPECTOR.
27. CONSTRUCTION SITES SHALL BE MAINTAINED IN SUCH A CONDITION THAT AN ANTICIPATED STORM DOES NOT CARRY WASTES OR POLLUTANTS OFF THE SITE OR INTO A CONNECTED SEWER OR STORM DRAIN.

DISCHARGES OF MATERIAL OTHER THAN STORM WATER ARE ALLOWED ONLY WHEN NECESSARY FOR PERFORMANCE AND COMPLETION OF CONSTRUCTION PRACTICES AND WHERE THEY DO NOT: CAUSE OR CONTRIBUTE TO A VIOLATION OF ANY WATER QUALITY STANDARD; CAUSE OR THREATEN TO CAUSE POLLUTION, CONTAMINATION, OR NUISANCE; OR CONTAIN A HAZARDOUS SUBSTANCE IN A QUANTITY REPORTABLE UNDER FEDERAL REGULATIONS 40 CFR PARTS 117 AND 302.

POTENTIAL POLLUTANTS INCLUDE BUT ARE NOT LIMITED TO: SOLID OR LIQUID CHEMICAL SPILLS; WASTES FROM PAINTS, STAINS, SEALANTS, GLUES, LIMES, PESTICIDES, HERBICIDES, WOOD PRESERVATIVES AND SOLVENTS; ASBESTOS FIBERS, PAINT FLAKES OR STUCCO FRAGMENTS; FUELS, OILS, LUBRICANTS, AND HYDRAULIC, RADIATOR OR BATTERY FLUIDS; FERTILIZERS, VEHICLE/EQUIPMENT WASH WATER AND CONCRETE WASH WATER; CONCRETE, DETERGENT OR FLOATABLE WASTES; WASTES FROM ANY ENGINE/EQUIPMENT STEAM CLEANING OR CHEMICAL DEGREASING; AND SUPERCHLORINATED POTABLE WATER LINE FLUSHINGS.

DURING CONSTRUCTION, DISPOSAL OF SUCH MATERIALS SHOULD OCCUR IN A SPECIFIED AND CONTROLLED TEMPORARY AREA ON-SITE, PHYSICALLY SEPARATED FROM POTENTIAL STORM WATER RUN-OFF, WITH ULTIMATE DISPOSAL IN ACCORDANCE WITH LOCAL, STATE AND FEDERAL REQUIREMENTS.

- 29. DEWATERING ON CONTAMINATED GROUNDWATER, OR DISCHARGING CONTAMINATED SOILS VIA SURFACE EROSION IS PROHIBITED. DEWATERING OF NON-CONTAMINATED GROUNDWATER REQUIRES A NATIONAL POLLUTANT DISCHARGE ELIMINATION SYSTEM PERMIT FROM THE RESPECTIVE STATE REGIONAL WATER QUALITY CONTROL BOARD.**



DIGITAL SUBMISSION REQUIREMENTS FOR ALL NEW DEVELOPMENTS AND IMPROVEMENT PLANS

To facilitate the transfer of information into the City's Geographic Information System (GIS), all plan submittals will be required to include digital graphic files in addition to the hard copy plans. Hard copy plans shall be prepared in accordance with the "City of San Clemente Public Works Department, Engineering Division, Plan Preparation Guidelines." Digital submittals shall be prepared in accordance with this document and will be required prior to final approval of plans by the City. Guidelines listed below may be revised by the City Engineer, periodically.

- Design Guidelines

1. Prepare drawings in model space (real earth coordinate). Use State Plane, California Zone VI, NAD 83 datum, units in feet, in accordance with the County of Orange Standards.
2. Tie two existing horizontal control points (minimum). Show locations of the points and bearing/distance/curve info.
3. Design with continuous polylines, NEVER use curves in a polyline.
4. Draw each parcel and/or building footprint with a polyline to form a closed polygon.
5. Use standard symbol blocks from City diskette for utility features.
6. Use paper space for any titleblock, legend, index, etc. information. Separate paperspace layers from design work and use easily recognizable layer names. Use standard AutoCAD fonts.
7. Submit separate drawing files for details of all utility stations and complex valve configurations.

- File Format and Media Requirements

Digital files shall be AutoCAD .dwg files if possible. If necessary, the City may accept ArcView .shp files or Microstation .dgn files. Image files (.tif, .pdf, .jpg, etc.) will NOT be accepted under any circumstances.

Digital files shall be submitted on 3.5" diskette or CD. The diskette or CD shall include a readme file in .doc or .txt format which will include an index of drawings and any explanations the city may need to use the digital files. The diskette or CD shall also include any data decompression software needed to extract the files.

- Data Layering Requirements

The following layer table details information which shall be included in ONE drawing file. For all new developments, each layer and its inclusions are REQUIRED. For improvements on existing facilities, include those layers necessary to show the new design in relation to existing conditions. For improvements only, existing conditions should be colored GRAY, new design shall follow the layer table.

<u>Layer Name</u>	<u>Linetype</u>	<u>Color</u>	<u>Text Font</u>	<u>Text Size</u>	<u>Inclusions</u>	<u>Comments</u>
(tract number, i.e. "12345")	CONTINUOUS	BLUE	ARIAL	20	Tract boundary(s) and label(s)	Drawn as a closed polygon. Text positioned so as not to interfere with utilities or roads.
addresses	CONTINUOUS	WHITE	ARIAL	10	Street Numbers	Each parcel shall be labelled. If street # is unknown, label parcel as "UNK" or "Lot XXX"
easements	DASHED	WHITE	ARIAL	10	Utility easements	If necessary.
elev	CONTINUOUS	GREEN	ARIAL	10	10-foot contours	Drawn as continuous polylines. Reference to MSL, labelled periodically using "text mask," NOT by breaking the polyline.
parcel	CONTINUOUS	WHITE			Parcel Boundaries	Each parcel shall be drawn as a closed polygon.
road_names	CONTINUOUS	WHITE	ARIAL	15	Road Names	Text positioned so as not to interfere with utilities, parallel with street CL
S_elev	CONTINUOUS	WHITE	ARIAL	10	Rim and Invert elevations.	As necessary.
S_Flow	CONTINUOUS	MAGENTA			Sewer flow direction arrows	See disk for symbol blocks.
S_Laterals	CONTINUOUS	MAGENTA			Sewer Laterals	Correct stationing on parcels.
S_Main	CONTINUOUS	MAGENTA			Sewer Mains	Drawn as much as possible with continuous polylines.
S_MH	CONTINUOUS	WHITE			Sewer Manholes	See disk for symbol blocks.
S_Pipe_Info	CONTINUOUS	MAGENTA	ARIAL	10	Sewer pipe material, depth, diameter, segment length, labelled "PVT" if private, labelled "Force" if force drain	See disk for symbol blocks.

<u>Layer Name</u>	<u>Linetype</u>	<u>Color</u>	<u>Text Font</u>	<u>Text Size</u>	<u>Inclusions</u>	<u>Comments</u>
S_Stations	CONTINUOUS	WHITE			Sewer stations	See disk for symbol blocks.
SD_CB	CONTINUOUS	WHITE			Storm Drain Catch Basin	See disk for symbol blocks.
SD_CL	CENTER	YELLOW			Storm Drain Centerlines	Drawn as much as possible with continuous polylines.
SD_Flow	CONTINUOUS	YELLOW			SD flow direction arrows	See disk for symbol blocks.
SD_MH	CONTINUOUS	WHITE			Storm Drain Manholes	See disk for symbol blocks.
SD_Open	PHANTOM	YELLOW			Open channel storm drains.	Use instead of SD_W. Drawn as much as possible with continuous polylines.
SD_Pipe_Info	CONTINUOUS	YELLOW	ARIAL	10	SD pipe material, diameter segment length, labelled "PVT" if private	See disk for symbol blocks.
SD_W	CONTINUOUS	YELLOW			Storm Drain Walls (pipes)	Drawn as much as possible with continuous polylines.
W_AV	CONTINUOUS	WHITE			Water Air-Vac's	See disk for symbol blocks.
W_BO	CONTINUOUS	WHITE			Water Blow-offs	See disk for symbol blocks.
W_FH	CONTINUOUS	RED			Fire Hydrants	See disk for symbol blocks.
W_Laterals	CONTINUOUS	RED			Water Laterals	Correct stationing on parcels.
W_Main	CONTINUOUS	RED			Water Mains	Drawn as much as possible with continuous polylines.
W_Met_Val	CONTINUOUS	WHITE			Water Meters and Valves	See disk for symbol blocks.
W_Pipe_Info	CONTINUOUS	RED	ARIAL	10	Water pipe material, diameter, segment length, and labelled "PVT" if private	See disk for symbol blocks.
W_Res	CONTINUOUS	CYAN	ARIAL	15	Reservoirs	Label appropriately.
W_Stations	CONTINUOUS	WHITE			PR Stations, Pump Stations	See disk for symbol blocks.
width_C2C	CONTINUOUS	WHITE	ARIAL	10	Curb-to-Curb Width	Text centered in street, perpendicular to street CL, text in parentheses
width_ROW	CONTINUOUS	WHITE	ARIAL	10	Right-of-Way Width	Text centered in street, perpendicular to street CL

Add additional layers ONLY as necessary for clear depiction.

- Checking of Digital Submittal

Digital data will be checked for the following:

1. Correct layering
2. Correct coordinate system.
3. Correct use of polylines in design.
4. Consistency between digital and hard copy plans.